



**MEGADYNE**



EN

## **V-BELTS**

TECHNICAL  
HANDBOOK

# INDEX

Introduction to V-belts	<b>2</b>
Product range	<b>5</b>
Technical calculation	<b>7</b>
Belt selection charts	<b>11</b>
Calculation example	<b>14</b>
Length measuring and groove pulleys	<b>17</b>
Storage maintenance and useful advices	<b>20</b>
Belt installation	<b>22</b>
Belt data	
Classical wrapped belts	
Extra - Oleostatic - Oleostatic Gold	<b>24</b>
Narrow wrapped V-belts DIN	
Extra - Oleostatic Gold	<b>52</b>
Narrow wrapped V-belts ARPM	
Oleostatic	<b>70</b>
Classical raw edge V-belts	
Linea Gold	<b>78</b>
Narrow raw edge V-belts DIN	
Linea X, Linea Gold	<b>86</b>
Variable speed V-belts	
Varisect	<b>104</b>
Double V-belts	
Esaflex	<b>110</b>
X-tra duty V-belts	
XDV2	<b>114</b>
Banded V-belts	
Pluriband	<b>118</b>
Useful formulas and conversion table	<b>124</b>
Data sheet	<b>126</b>

# INTRODUCTION TO V-BELTS



Megadyne V-belts have been used for decades in the most different industries and applications, offering drive solutions to customers all over the world.

Applied technology guarantees dimensional precision in V-belts allowing them to be suitable for multiple transmissions. This dimensional stability continues also during belt use.

The variety of belt sizes available allows the application of Megadyne V-belts on a wide range of drive applications, such as:

- Machine tools
- Industrial washing machines
- Textile machines
- Continuous paper machines
- High-power mills
- Stone crushers

The main V-belt components are:

- 1. Belt body** made of a special rubber compound which provides, thanks to its excellent mechanical characteristics, high-transmission efficiency and assures a minimum rubber wear off;
- 2. Tensile member** consisting of high-strength and low-stretch cords, which grant length stability over the belt lifetime;
- 3. Fabric** jacket or cover made of fabric, protecting the tensile member and permitting the use of backside idler. Our wide range of products with different power rates and several structures allows Megadyne to always find the best solution for a very wide spectrum of applications.

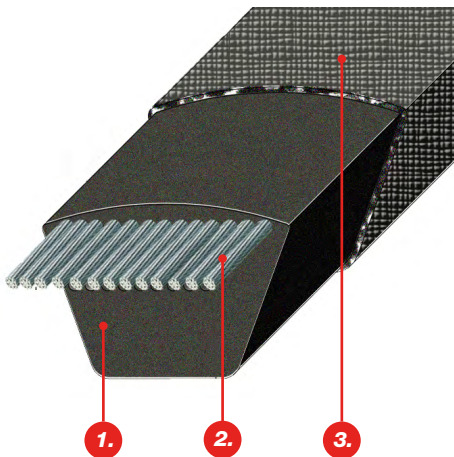

## MECHANICAL AND CHEMICAL FEATURES

- Smooth starting and running
- Wide range of driven speed
- Low maintenance
- High efficiency
- Extremely wide horsepower ranges
- Dampen vibration between driver and driven pulleys
- Silent operations
- Long life service
- Easy installation
- Reduction in drive dimension
- Working temperature range from -30°C to +80/90°C (see details in family pages)
- Oil and heat resistance
- Antistatic properties

## MEGAMATCH **MEGA MATCH**

All V-belts carrying the MEGA MATCH logo are made, and supplied, according to the matching set tolerances and limits indicated by the relevant international standards (ISO 4184, ARPM, etc).

# INTRODUCTION TO V-BELTS

## WRAPPED V-BELTS

### EXTRA

Extra belts were designed to offer durable and reliable performances on light and medium-duty drives. They represent an affordable solution for transmission systems of all industrial sectors.

### OLEOSTATIC

Oleostatic rubber belts are developed with high-resistant tensile elements, they are characterised by high performance, length stability during the life of the belts, conductivity, oil, and heat resistance. They are particularly suitable for centrifugal pumps, compressors, tool machines, generators, high-power mills, and stone mills.

### OLEOSTATIC GOLD

Different materials and design features, together with an improved production process, have led to the development of a complete range of higher rated wrapped V-belts. The Oleostatic Gold V-belts products family can operate in a wide range of industrial applications, within a large spread of load capacities and speeds — offering rated performance from 100 to 8,000 RPM and power capability from 1 to 400 kW, meanwhile granting large cost advantages for the end-users.

Oleostatic Gold structure:

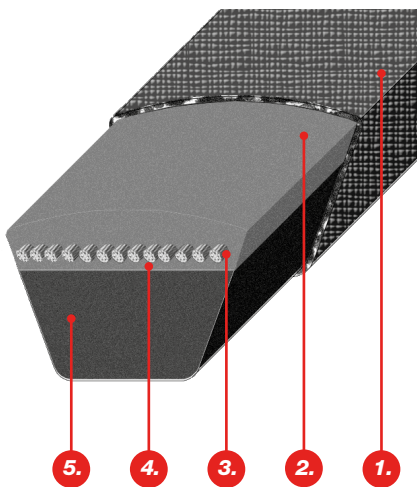

**1. FABRIC:** Double cover ply - CR Dip.

A reinforced double-fabric cover is plied around the belt to protect it against contamination and moisture. Its increased flexibility allows the belt to bend more easily around the smallest pulleys with far less strain on the fabric, while assuring a smoother running drive.

**2. TOP CUSHION:** SBR compound + Fibers

**3. TENSILE CORD:** H.T. Polyester

The tensile section is made up of a multiple number of high-strength, low-elongation polyester cords, completely embedded in the adhesion layers, to enhance resistance to tension and flex fatigue. Each cord is individually and specially coated to secure a long-lasting bond with the surrounding rubber and to grant a longer operational lifetime. In addition, the belt requires significantly less retensioning and take-up thanks to its cord's consistent length stability. A longer life of the belt means less frequent replacement, less downtime, and lower maintenance costs.

**4. BOTTOM CUSHION:** SBR compound + Fibers

**5. BODY COMPOUND:** Polychloroprene (CR) based

# INTRODUCTION TO V-BELTS

## RAW EDGE V-BELTS

### LINEA X

These belts have been specifically developed to run where small pulleys diameters and high-transmission ratios put a limit to the use of wrapped belts of the same section.

Compared to wrapped belts, the Linea X family offers important improvements, like specific compounds and special production technology. In particular, the transverse orientation of the fibers improves the cord's support capacity of the body section and reinforces its transverse rigidity, while maintaining, (thanks to the cogged profile and the precision-ground sidewalls) the highest longitudinal flexibility and running stability. These characteristics guarantee an excellent structure with advantages such as: high-transmission ratios, improved grip, and resistance to continuous bending.

### LINEA GOLD

Selected materials, advanced design features, and an innovative production process has led Megadyne to develop a complete range of raw edge V-belt drives that outperform, in a wide range of industrial applications, all the previous drives equipped with standard raw edge belts, granting large cost advantages for the end-users and greater design flexibility for the engineers. The belt has a narrow cross section and a raw edge construction, based on EPDM rubber compound which can withstand chemically aggressive environments, ageing, ozone, UV, and heat.

Linea Gold structure:

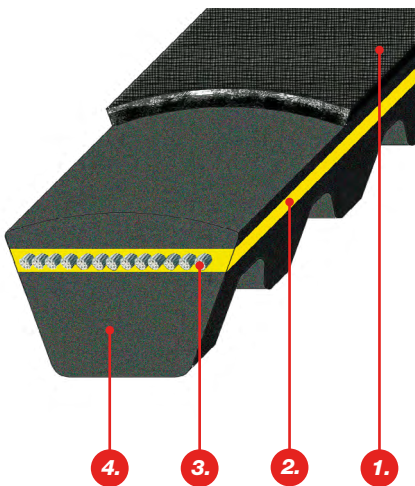

- 1. BACKSIDE FABRIC:** The textile fabric is plied on the belt backside to protect it against contamination and moisture. Its flexibility gives the belt excellent reversed bending properties, when backside idlers are used, and protects the belt against wear.
- 2. ADHESION LAYERS:** The high-performing, coloured, EPDM compound located immediately above and below the belt cords, guarantees the best possible bonding with the under cord body material.
- 3. TENSILE CORD:** The tensile section is made up of a multiple number of high-strength, low-elongation polyester tensile cords which are completely embedded in the adhesion layers and vulcanized as one solid unit to enhance resistance to tensile and flex-fatigue forces. On request, for special extreme requirements, aramid or glass fibre cords are also available.
- 4. BODY COMPOUND:** The EPDM compound, with high-performance fibers embodied in the rubber matrix, provides superior abrasion and wear resistance to the belt. The transversal orientation of the fibers improves the cord support capacity of the body section and reinforces its transversal rigidity, while maintaining, in connection with the cogged profile and the precision-ground sidewalls, the utmost longitudinal flexibility and running stability.

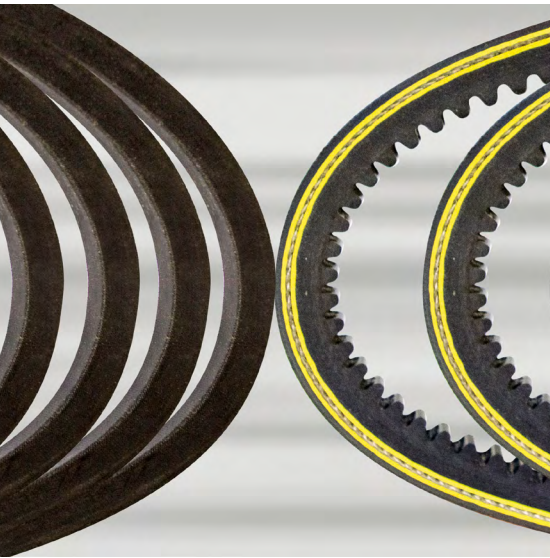

# PRODUCT RANGE



**CLASSICAL WRAPPED V-BELTS**  
(Extra - Oleostatic - Oleostatic Gold)

SECTIONS	
Z	E
A	20
B	25
C	45
D	50

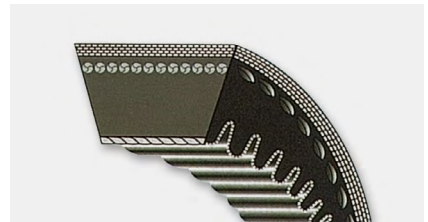

**CLASSICAL RAW EDGE V-BELTS**  
(Linea Gold)

SECTIONS	
AX	
BX	
CX	



**NARROW WRAPPED V-BELTS DIN**  
(Extra - Oleostatic Gold)

SECTIONS	
SPZ	
SPA	
SPB	
SPC	



**NARROW RAW EDGE V-BELTS DIN**  
(Linea X - Linea Gold)

SECTIONS	
XPZ	
XPA	
XPB	
XPC	



**NARROW WRAPPED V-BELTS ARPM**  
(Oleostatic)

SECTIONS	
3V	
5V	
8V	



# PRODUCT RANGE



## VARIABLE SPEED V-BELTS

(Varisect)

SECTIONS	
13x6	36x12
17x6	37x10
21x7	42x13
22x8	47x13
26x8	52x16
28x8	55x16
30x10	65x20
32x10	70x20



## XTRA DUTY V-BELTS

(XDV2)

SECTIONS
XDV2-38
XDV2-48
XDV2-58



## DOUBLE V-BELTS

(Esaflex)

SECTIONS
AA
BB
CC



## BANDED V-BELTS

(Pluriband)

SECTIONS	
RA	RSPC
RB	R3V
RC	R5V
RSPZ	R8V
RSPA	R3VX
RSPB	R5VX

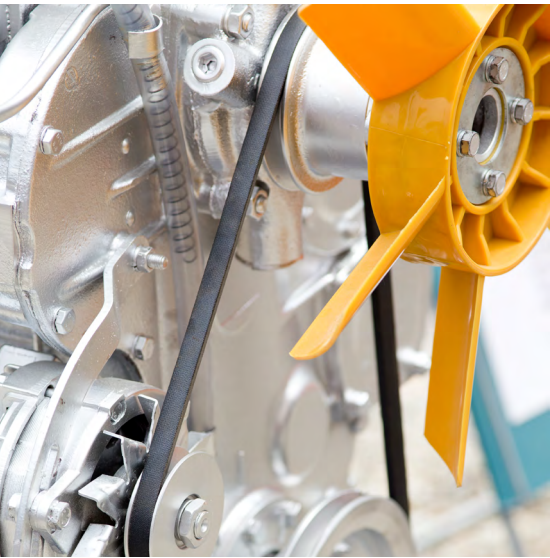

# TECHNICAL CALCULATION

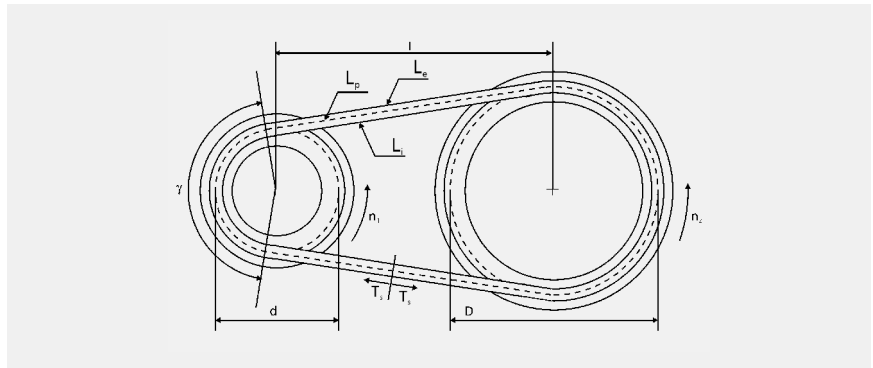

SYMBOL	UNIT	DEFINITION
$C_f$		correction factor $C_f$
$C_L$		correction factor $C_L$
$C_c$		correction factor $C_c$
$d$	mm	pitch diameter of smaller pulley
$D$	mm	pitch diameter of bigger pulley
$I$	mm	theoretical center distance
$I_e$	mm	effective center distance
$i$		transmission ratio
$L'$	mm	calculated pitch length
$L_e$	mm	external length ( $L_p + \Delta_e$ )
$L_i$	mm	internal length ( $L_p - \Delta_i$ )
$L_p$	mm	pitch length (effective)
$n_1$	RPM	speed of smaller pulley (faster)
$n_2$	RPM	speed of bigger pulley (slower)
$P$	kW	power to be transmitted
$P_a$	kW	actual power of the transmission
$P_b$	kW	basic performance of a single belt
$P_c$	kW	corrected power
$P_d$	kW	difference to $P_b$ due to $K \neq 1$
$Q$		number of belts
$T_s$	N	static belt tension
$v$	m/s	peripheral belt speed
$\gamma$	°	arc of contact



# TECHNICAL CALCULATION

## BELT SECTION

Necessary data for selection of the belt section:

<b>P</b>	power to be transmitted in kW
<b>n<sub>1</sub></b>	speed in RPM of the smaller pulley
<b>n<sub>2</sub></b>	speed in RPM of the bigger pulley

It is necessary to correct the power P by a coefficient C<sub>c</sub> (see table 1 on page 6) which takes into account the actual operating conditions.

Corrected power P<sub>c</sub> is given by:

$$P_c = P \cdot C_c$$

The graphs give a guiding criterion for the section of the belt.

## TRANSMISSION RATIO

Transmission ratio is calculated as follows:

$$i = \frac{n_1}{n_2} = \frac{D}{d}$$

where D is the pitch diameter of the larger pulley and d is the pitch diameter of the smaller pulley.

The peripheral speed of the belts is determined by

$$v = \frac{d \cdot n_1}{19100}$$

If the drive being calculated is of the V/flat type (one V pulley and one flat pulley) it is necessary to find the corresponding pitch diameter of the flat pulley.

The pitch diameter of the flat-faced pulley is obtained by increasing its external diameter by the amount in millimetres shown in the following table:

Z	A	B	C	D	E	19	20	25
8	10	14	20	24	33	16	15	19



# TECHNICAL CALCULATION

## PITCH LENGTH OF THE BELT AND CORRECT CENTER DISTANCE

Whenever the shaft center distance  $l$  is not predetermined by the layout of the drive, the optimum distance may be chosen as follows:

$1 < i < 3$	$l \geq \frac{(i+1) \cdot d}{2} + d$
$i > 3$	$l \geq D$

The pitch length is determined by:

$$L' \approx 2 \cdot l + 1,57 \cdot (D+d) + \frac{(D-d)^2}{4l}$$

From the list of belt sizes, should be selected the belt pitch length  $L_p$  nearest to the value of  $L'$  above calculated.

Since  $L' \neq L_p$  the center distance " $l$ " may be varied by subtracting half  $L' - L_p$ . Therefore, the effective center distance of the drive will be:

$$l_e = l - \frac{(L' - L_p)}{2}$$

## NUMBER OF BELTS

The basic performance  $P_b$  is the power that a single belt transmits under the following conditions:

$$i = 1$$

This configuration corresponds to 180° arc of a contact belt on both pulleys;

$$i \neq 1$$

The difference of kW-rating  $P_d$  is the power that the belt transmits in excess of  $P_b$  because  $i \neq 1$  in service conditions.

The actual kW-rating  $P_a$  is the power that the belt transmits in operating conditions and is obtained by means of:

$$P_a = (P_b + P_d) \times C_g \times C_L$$

Table 4 (see belt family pages) gives the values of  $P_b$  according to RPM and  $d$  (smaller diameter) and the values of  $P_d$  according to RPM and  $i$ .



# TECHNICAL CALCULATION

Table 2 (bottom of this page) and 3 (see belt family pages) give values of the coefficients  $C_\gamma$  and  $C_L$  taking into account the operating conditions.

The arc of contact  $\gamma$  of the belt on the smaller pulley is determined by:

$$\gamma = 180^\circ - 57 \cdot \frac{D-d}{l_e}$$

The number of belts  $Q$  necessary for the transmission of the power  $P_c$  is determined by:

$$Q = \frac{P_c}{P_a}$$

The number of belts is actually obtained in general by rounding up  $Q$  to the next highest whole number.

TABLE 1 - TYPE OF MOTOR						
Applications	Daily operating hours					
	0-8 <sup>(1)</sup>	8-16 <sup>(1)</sup>	16-24 <sup>(1)</sup>	0-8 <sup>(2)</sup>	8-16 <sup>(2)</sup>	16-24 <sup>(2)</sup>
<b>Light use</b>						
Centrifugal pumps and compressors, belt conveyors, (light materials) fans and pumps up to 7,5 kW.	1,1	1,1	1,2	1,1	1,2	1,3
<b>Normal use</b>						
Shears for steel sheet presses, belt and chain conveyors, (heavy material) sifters, generator sets, machine tools, kneading machines, industrial washing machines, printing presses, fans and pumps over 7,5 kW.	1,1	1,2	1,3	1,2	1,3	1,4
<b>Heavy use</b>						
Hammer mills, piston compressors, belt conveyors for heavy loads, lifters, textile machines, continuous paper machines, piston and dredging pumps, ripping saws.	1,2	1,3	1,4	1,4	1,5	1,6
<b>Extra heavy use</b>						
High power mills, stone crushers, calendars, mixer, cranes, diggers, dredgers.	1,3	1,4	1,5	1,5	1,6	1,8

### Drivers

(1) AC electric motors: high slip, squirrel cage, synchronous; DC electric motors: parallel excitation; multi-cylinder internal combustion engines; gas or steam turbines.

(2) AC electric motors: high torque, high slip, single phase, wound rotor, commutator; DC electric motors: series and compound excitation; single-cylinder internal combustion engines with direct coupling or with countershaft; steam engines.

TABLE 2 - CORRECTION FACTOR $C_\gamma$																			
(T/T=V/V DRIVES; T/P=V/FLAT DRIVES; $\gamma$ =ARC OF CONTACT ON THE SMALLER PULLEY)																			
	$\gamma$	180°	175°	170°	165°	160°	155°	150°	145°	140°	135°	130°	125°	120°	115°	110°	105°	100°	90°
$C_\gamma$	T/T	1	0,99	0,98	0,96	0,95	0,93	0,92	0,90	0,89	0,87	0,86	0,84	0,82	0,80	0,78	0,76	0,74	0,69
	T/P	0,75	0,76	0,77	0,79	0,80	0,81	0,82	0,83	0,84	0,85	0,86	0,84	0,82	0,80	0,78	0,76	0,74	0,69



# BELT SELECTION CHARTS

## WRAPPED V-BELTS

### CLASSICAL WRAPPED V-BELTS

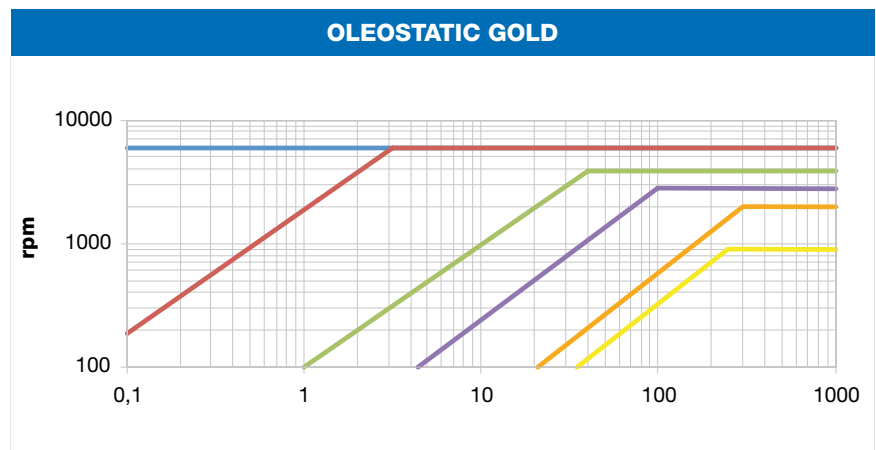
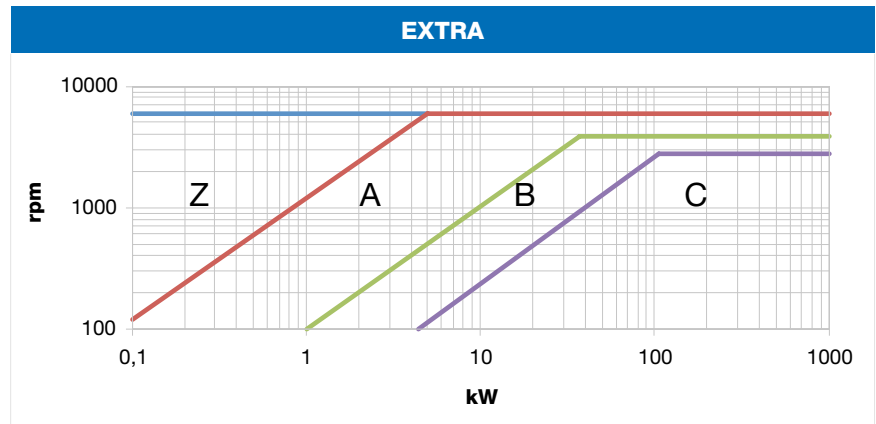



# BELT SELECTION CHARTS

## WRAPPED V-BELTS

### NARROW WRAPPED V-BELTS DIN

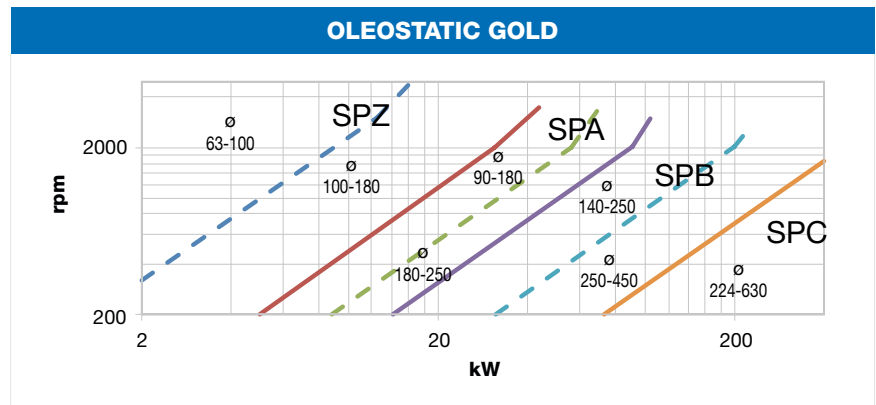
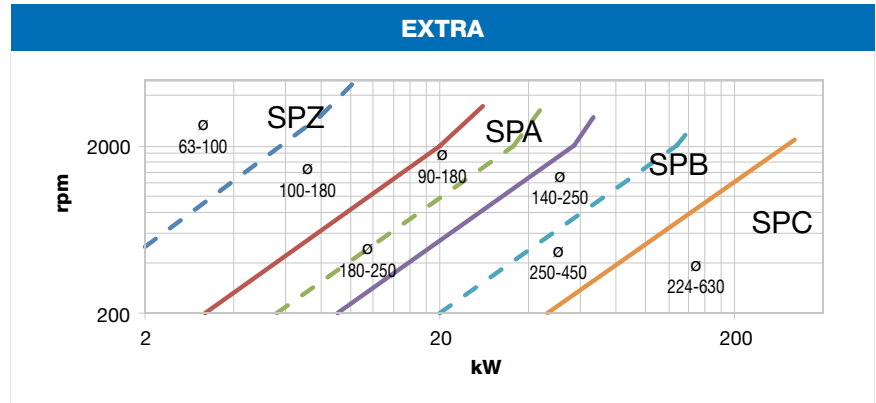

### NARROW WRAPPED V-BELTS ARPM

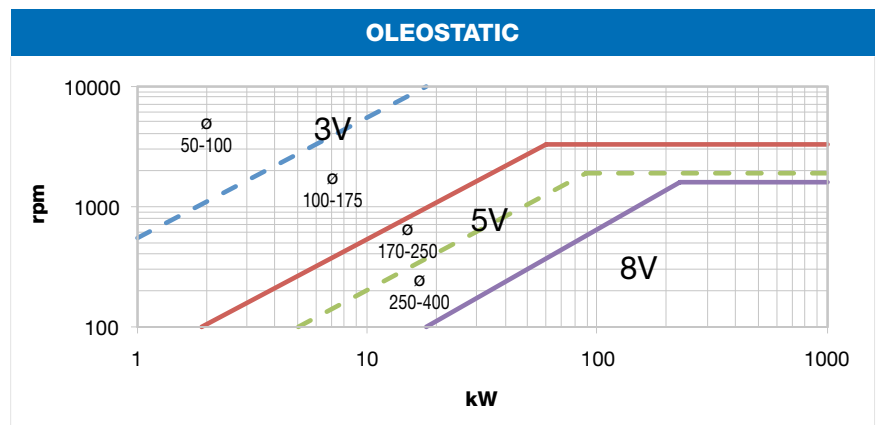



# BELT SELECTION CHARTS

## RAW EDGE V-BELTS

### CLASSICAL RAW EDGE V-BELTS

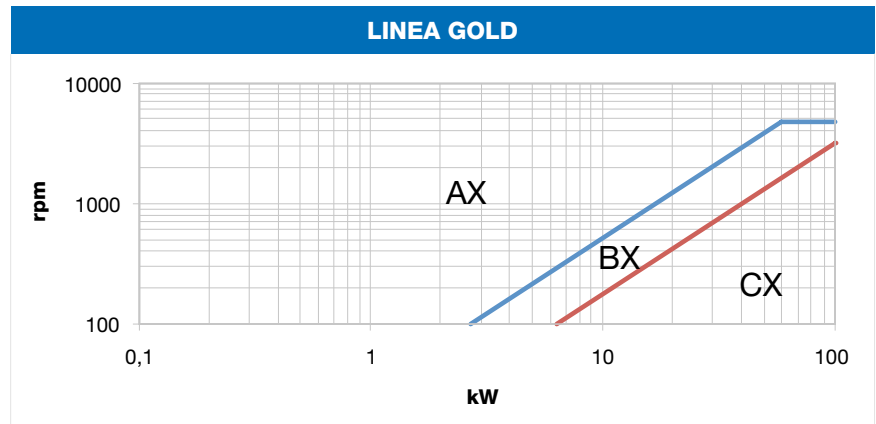

### NARROW RAW EDGE V-BELTS DIN

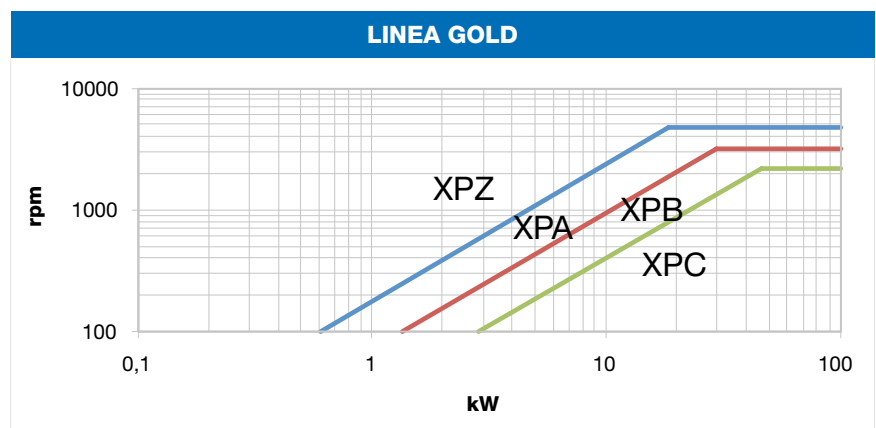
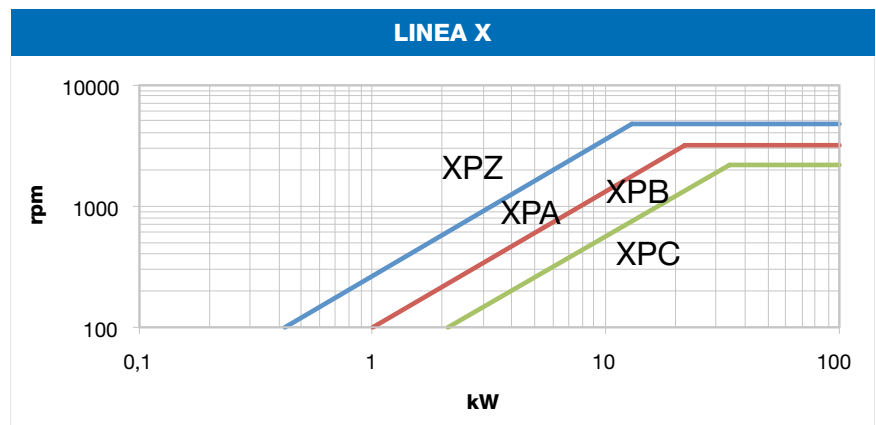

# CALCULATION EXAMPLE

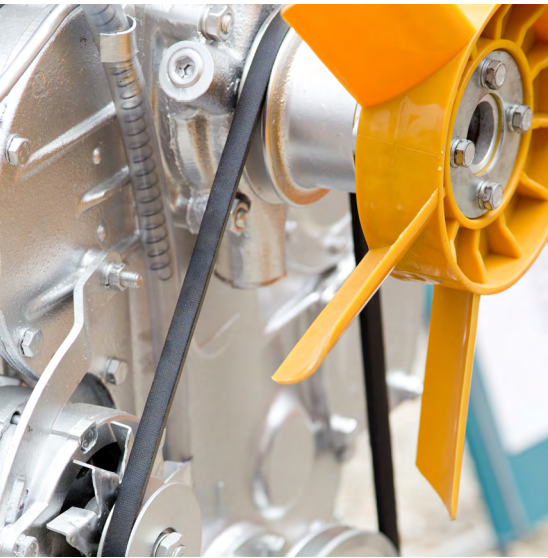

## BELT SELECTION

From selection charts, for  $P_c = 28,6$  and  $n_1 = 1200$  RPM it is appropriate to choose section B.

## TRANSMISSION RATIO

The transmission ratio can be calculated as follows:

$$i = \frac{n_1}{n_2} = \frac{1200}{660} = 1,82$$

Considering diameter  $d = 250$  mm for the smaller pulley, the pitch diameter of the larger pulley is:

$$D = i \cdot d = 1,82 \cdot 250 = 455 \text{ mm}$$

The peripheral speed of the belts is determined by

$$v = \frac{d \cdot n_1}{19100} \quad v = \frac{0,052 \cdot 250 \cdot 1200}{19100} = 15,7 \text{ m/s}$$

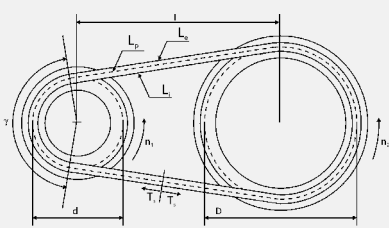

## EXAMPLE

$P = 22$  kW

$n_1 = 1200$  RPM

$n_2 = 660$  RPM

Textile machine operating time:  
12 hours a day

Type of motor:  
ac electric motor, normal torque

Correction coefficient:  
1,3 (see table 1)

Corrected power:  
 $P_c = 22 \cdot 1,3 = 28,6$  kW

## BELT PITCH LENGTH AND CORRECT CENTER DISTANCE

For  $i = 1,82$  (i.e.  $1 < i < 3$ ) the center distance is given by:

$$l \geq \frac{(i+1) \cdot d}{4} + d \quad \text{so} \quad l = 610 \text{ mm}$$

The pitch length of the belt is determined by:

$$L' = 2 \cdot l + 1,57 \cdot (D+d) + \frac{(D-d)^2}{4 \cdot l}$$

$$L' = 2 \cdot 610 + 1,57 \cdot (455+250) + \frac{(455-250)^2}{4 \cdot 610} = 2344 \text{ mm}$$

From the list of belt sizes (see table on belt family pages), should be selected the belt pitch length  $L_p$  nearest to the value of  $L'$  previously calculated.

The center distance "l" may be varied by subtracting half  $L' - L_p$ . Therefore, the effective centre distance of the drive will be:

$$l_e = l - \frac{L' - L_p}{2}$$



## CALCULATION EXAMPLE

Having selected **Oleostatic Gold B 91** ( $L_p = 2355$  mm), the actual shaft center distance is calculated by:

$$l_e = 610 - \frac{2344-2355}{2} = 615,5 \text{ mm}$$

From table 4 of B section ( $d=250$  mm; 1200 RPM;  $K=1,82$ ):

$$P_b = 11,57 \text{ kW}$$

$$P_d = 0,48 \text{ kW}$$

The arc of contact  $\gamma$  of the belt on the smaller pulley is determined by:

$$\gamma = 180^\circ - 57 \cdot \frac{D-d}{l_e} = 180^\circ - 57 \cdot \frac{455-250}{616} \cong 161^\circ$$

From table 2 for  $\gamma = 161^\circ$

$$C_\gamma = 0,95$$

From table 3, on page 19 for Oleostatic Gold B 91 belt

$$C_L = 1,00$$

Therefore:

$$P_a = (11,57+0,48) \cdot 0,95 \cdot 1,00 = 11,45 \text{ kW}$$

The number of belts  $Q$  necessary for transmission of the power  $P_c$  is established by:

$$Q = \frac{P_c}{P_a} = \frac{28,6}{11,45} = 2,5$$

Round up to 3 belts **Oleostatic Gold B 91**.



# CALCULATION EXAMPLE

## BELT TENSIONING RECOMMENDATION

The correct belt assembling tension is given by:

$$T_s = 500 \cdot \frac{2,5 - C_\alpha}{C_\alpha} \cdot \frac{P_c}{Q \cdot v} + m \cdot v^2$$

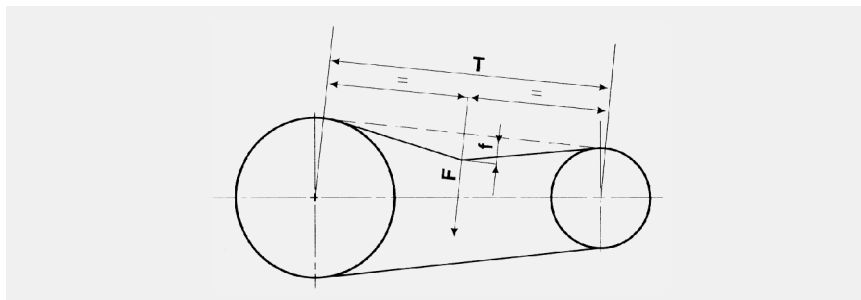

SYMBOL	UNIT	DEFINITION
$C_\alpha$		arc correction factor
$m$	kg/m	belt linear mass (see belt family page)
$P_c$	kW	corrected power
$Q$		number of belts
$T_s$	N/strand	static belt tension
$v$	m/s	peripheral belt speed
$\alpha$	°	arc of contact

Arc correction factor:

$\alpha$ [°]	180	174	169	163	157	151	145	139	133	127	120	113	106	99	91	83
$C_\alpha$	1,00	0,98	0,97	0,96	0,94	0,93	0,91	0,89	0,87	0,85	0,82	0,80	0,77	0,73	0,70	0,65

# LENGTH MEASURING

## AND GROOVE PULLEYS

### BELT LENGTH MEASURING

The first and easiest way to measure the V-belt's length is by placing the belt on a flat surface, giving the belt a circular shape, and finally measuring the internal length  $L_i$  by means of a measuring tape. Adding  $\Delta_i$  and after  $\Delta_e$  (see belt families pages) to this length, it's possible to calculate respectively  $L_p$  and  $L_e$ .

This measurement way is not very precise, even if practically easy and feasible with only a tape.

The correct way to measure the V-belt's length is by means of pulleys and dynamometers.

The belt is put on 2 pulleys, specific for the family and size of the belt, and having the same pitch diameter. One is fixed while the second one can move on a linear graduated scale.

Depending on the belt, a certain force is applied to the second pulley in order to put the complete system under tension. The correct force is tabled by the relevant standards referring to the belt family.

To stabilize the system, at least 3 rotations of the pulleys are required.

The pitch length  $L_p$  is given by the pulley's pitch diameter  $D$  and center distance  $a$  in the formula:

$$L_p = 2 a \cdot \pi D$$

Subtracting  $\Delta_i$  and adding  $\Delta_e$  (see belt families pages) it's possible to calculate respectively  $L_i$  and  $L_e$ .

### GROOVE PULLEYS

Groove pulleys for V-belts must be manufactured with care and made of a good quality steel or engineering cast iron. It is most important that the flanks of the grooves shall be perfectly smooth and show no visible sign of machining, that all sharp corners of the grooves shall be rounded off and chamfered, and that the external diameter of the face shall be constant overall.

All pulleys must also be statically balanced. Dynamic balancing is required for speeds over 30 m/second.

Profile and dimension of the pulley should be in accordance with DIN 2211, BS 3790, ISO, and ARPM depending on the belt's relevant standard.

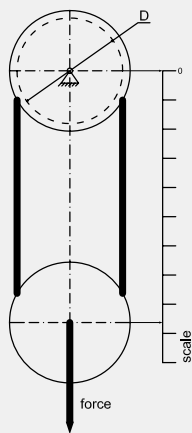
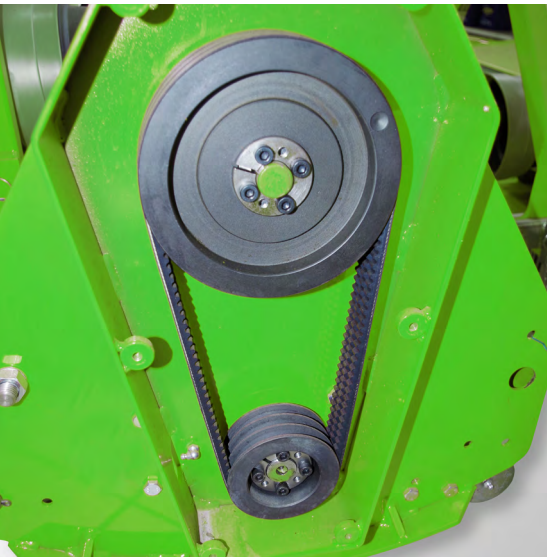



# LENGTH MEASURING

## AND GROOVE PULLEYS

- $l_p$  = pitch width
- $k$  = minimum height of groove above the pitch line
- $h$  = minimum depth of groove below the pitch line
- $\alpha$  = groove angle
- $d$  = pitch diameter
- $e$  = distance between the axes of the sections of two grooves
- $f$  = distance between the axis of the section of the outer groove and the rim of the pulley

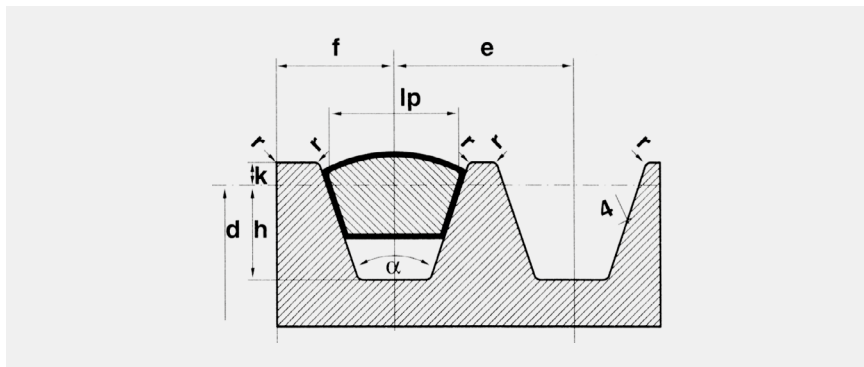

In the drawing are shown the main characteristics and dimensions of the groove pulleys for V-belts (example referring to Oleostatic belts).

The use of idlers in V-belt drives is not recommended.

However, due to particular drive requirements and limitations, the use of idlers may be absolutely necessary.

For using idlers, the requirements are as follows:

1. Providing take-up for fixed center drives.
2. Turning corners (as in mule pulley drives).
3. Breaking up long spans where belt whip may be a problem.
4. Maintaining tension when the idler is spring-loaded or weighted.

A power correction (see below) is required.

### RECOMMENDED

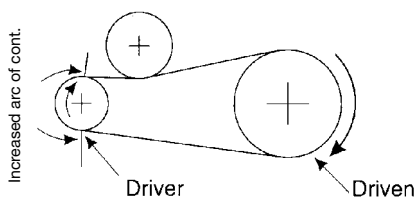

### NOT RECOMMENDED

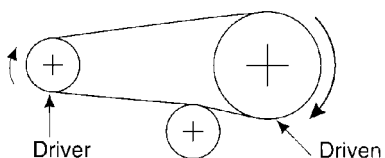

### OUTSIDE IDLER

1. An outside idler should be at least one and one-third times as large as the smallest pulley on the drive, unless the drive has unusually large pulleys.
2. An outside idler must be flat and without any crown.
3. To find the face width of a flat idler (between flanges if flanged) add 1 1/2 times the nominal belt top width to the face width of the grooved pulley used.
4. An outside idler pulley should be located as close as possible to the preceding pulley. This is because the V-belts slightly move back and forth on a flat pulley; locating it far away from the next pulley minimizes the possibility of the belt of entering that pulley in a misaligned condition.
5. Idler pulleys should be located only on the slack side of a drive.



# LENGTH MEASURING

## AND GROOVE PULLEYS

### RECOMMENDED

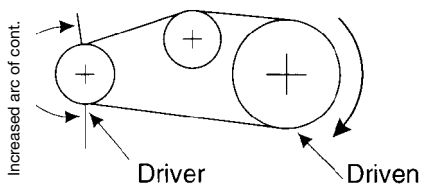

### NOT RECOMMENDED

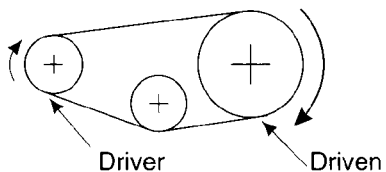

### INSIDE IDLER

1. An inside idler will decrease the arc of contact.
2. An inside idler should be at least as large as the smallest pulley on the drive, unless the drive has unusually large pulleys.
3. An inside idler should better be a grooved pulley. In alternative, flat pulleys can be used.
4. A grooved inside idler pulley may be located anywhere along the span, preferably so that it gives nearly equal arcs of contact on the two adjacent pulleys.
5. Idler pulleys should be located only on the slack side of a drive.

### RATED POWER CORRECTION

Because idlers impose an additional bending stress point on the V-belt, the transmittable power is reduced.

The smaller the idler diameter, the greater the bending stress, which results in a greater reduction in rated power and belt life.

To compensate for this loss, the design power of the drive must be increased.

The following table gives the approximate correction factors according to the number of pulleys in the drive.

The normal power rating should be multiplied by this factor.

N° of pulleys in the drive	2	3 (one idler)	4 (two idlers)
Rating Correction Factor	1,00	0,90	0,80

**Note:** As stated, the above listed factors are only approximate values and apply only when idler diameters and their location are in accordance with the above recommendations.

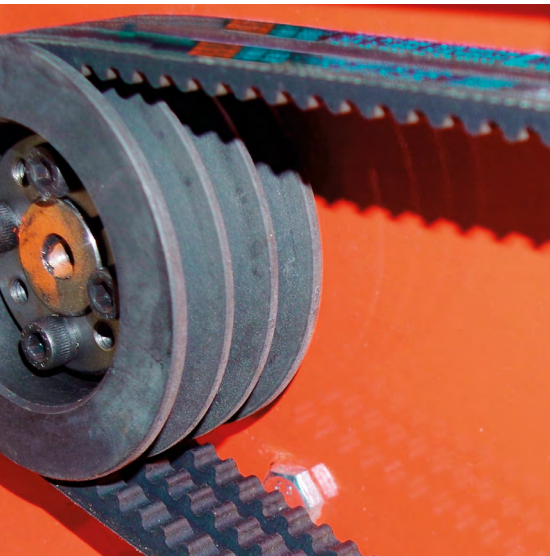

# STORAGE MAINTENANCE

## AND USEFUL ADVICES

### HOW TO STORE BELTS

In order to store the V-Belts correctly, it is advisable to hang them on “saddles” or on large-diameter tubular brackets. This diameter should be at least ten times the height of the belts’ cross section.

Long belts can be stacked to save space, provided that they are correctly coiled (see figures).

Short belts can be stored on shelves but be aware that stacks should not be more than 300 mm high as the bottom belts may be otherwise deformed.

Finally, hooks and nails are unsuitable for suspending the belts.

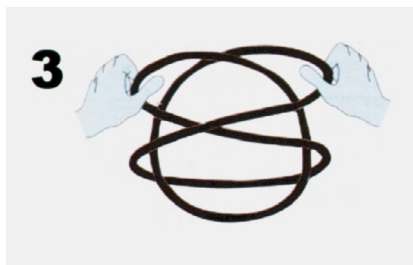
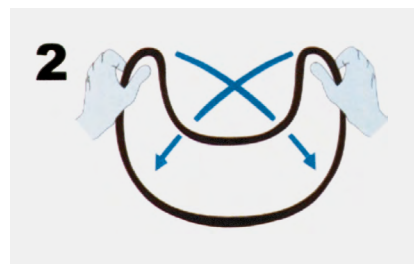
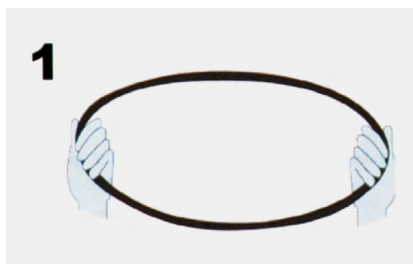

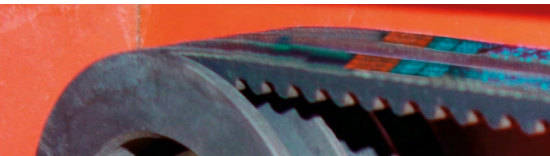

# STORAGE MAINTENANCE

## AND USEFUL ADVICES

### **CONDITIONS OF STORAGE**

Rubber V-belts can be stored for several years without causing any performance or reliability loss.

For correct storage, some prescription must be taken into account.

### **ENVIRONMENT**

The storage premises should be cool, dry, and well ventilated but not draughty.

### **TEMPERATURE**

Storage temperatures should be within +5 and +30°C.

Lower temperatures cause stiffening in the belt but are accepted in the storage. In order to avoid damages in the start-up, it becomes necessary to heat the belt up to around 20° before making it run on the machine.

Higher temperatures due to heating are to be avoided. The distance from heating sources should be at least 1 meter.

### **LIGHT**

Belts should be protected from light, especially direct sunlight and artificial light, with high ultraviolet rays (neon light).

### **OZONE**

Equipment generating ozone, like high-voltage electrical machines or fluorescent light sources, should not be installed in the storage.

Also, combustion gases and vapours, that can cause ozone, should be avoided.

### **CHEMICALS**

Flammable materials, lubricants, acids, and any other aggressive material should not be kept in the storage. Belts elastomers may be affected, or even irreparably damaged, by such agents.

### **CLEANING**

Never clean the V-belts. If you need, for any reason, to clean the belts use a dry towel or one soaked with a glycerine/alcohol mixture in the ratio 1:10. Other solvents such as petrol or benzene must not be used.

Sharp-edged objects must not be used for cleaning the V-belts.

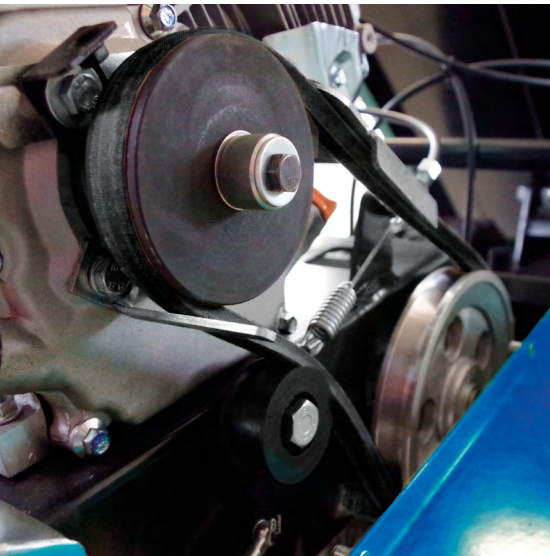

# BELT INSTALLATION

To ensure a long service-life and high-performance, it is important to correctly design the application and to take care of the correct installation, maintenance, and storage of the belt.

A drive must be designed in such a way to make proper provision for both installation and tensioning of the V-belts.

For this purpose, a take-up device is necessary; a slide adjuster on the motor is recommended to simplify installation and permit optimum tensioning.

Table 5 (see belt family pages) provides the minimum variation of center distance permitted for the installation and the tensioning of the belts.

Furthermore, the following rules must always be observed:

- 1.** Check the alignment of the drive pulleys;
- 2.** Make sure that the flanks of the grooves are clean;
- 3.** Adjust the tensioner to stretch the belts sufficiently;
- 4.** Check the tension (see following section);
- 5.** Check the correct diameter for tensioning pulley;
- 6.** Protect the belts from oil and other chemicals;
- 7.** When installing belts, slack off the tensioner and avoid using tools or implements which may damage the belts.

Pulleys with large diameters increase the life of the belt. They must be statically balanced up to the speed of 30 m/s and dynamically balanced over this value.

- x = Take up allowance
- y = Installation allowance
- l = Center distance

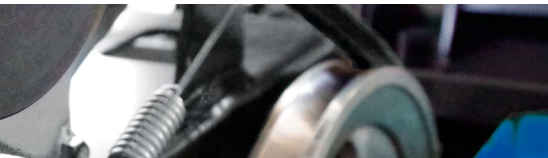

# BELT INSTALLATION

## TENSIONING SYSTEM

The satisfactory performance of a transmission equipped with V-belts depends on the correct fitting tension.

It is therefore necessary to proceed in the following way, using the slide adjuster:

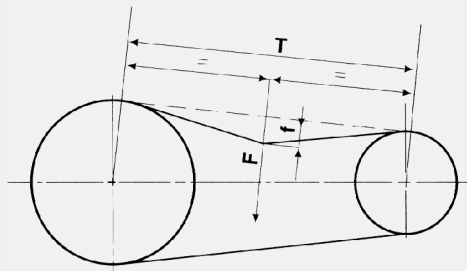

### BELT TENSION CONTROL BY DEFLECTION METHOD

The approximate relation among deflection force, belt deflection and belt tension is given by:

$$T_s \approx \frac{f \cdot t}{4 \cdot f}$$

Imposing a belt deflection:

$$f = \frac{t}{64}$$

The deflection force should be in the range:

$$F_{\min} \approx F' = \frac{T_s}{16}$$

$$F_{\max} \approx F'' = \frac{1,5 \cdot T_s}{16}$$

where:

SYMBOL	UNIT	DEFINITION
<b>F</b>	N	perpendicular deflection force
<b>f</b>	mm	belt deflection
<b>t</b>	mm	free span length
<b>T<sub>s</sub></b>	N/strand	static belt tension (see page 9)

### BELT TENSION CONTROL BY VIBRATION METHOD

Belt vibration frequency:

$$F_r = \frac{T_s}{4 \cdot m \cdot t^2}$$

SYMBOL	UNIT	DEFINITION
<b>F<sub>r</sub></b>	Hz	natural frequency of belt
<b>m</b>	kg/m	specific belt mass
<b>t</b>	m	free span length
<b>T<sub>s</sub></b>	N/strand	static belt tension (see page 9)



MEGADYNE V-BELTS

# CLASSICAL WRAPPED V-BELTS

EXTRA  
OLEOSTATIC  
OLEOSTATIC GOLD

# CLASSICAL WRAPPED BELTS

## EXTRA - OLEOSTATIC OLEOSTATIC GOLD

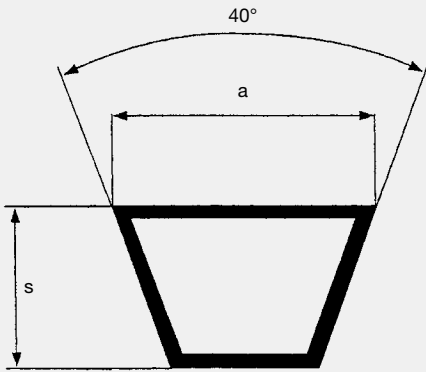

BELT CHARACTERISTICS										
SECTION	Z	A	B	C	D	E	20	25	45	50
a (mm)	10	13	17	22	32	40	20	25	45	50
s (mm)	6	8	11	14	19	25	12,5	16	20	20
Pitch length - internal length = $\Delta i$ (mm)	25	33	43	62	76	105	48	61	91	85
External length - pitch length = $\Delta e$ (mm)	13	17	26	26	43	52	31	39	35	41
Weight (gr/m)	60	100	175	300	610	930	240	400	1200	1365
Min. Pulley diam. (Mm)	60	90	125	180	300	500	160	250	320	320
Working temperature	-30°C / +80°C									
Relevant standards	ARPM/MPTA IP20 - DIN 2215 - ISO 4184									
Relevant antistatic standard	ISO 1813									
Materials	SBR and/or CR blend - polyester cord - cotton/polyester fabric									

TABLE 3 - CORRECTION FACTOR $C_L$ (according to type and length of the belt)																							
INCHES	9½	16	22	24	28	32	35	48	53	75	81	90	128	144	180	210	285	330	420	540	720	780	
Z	0,69	0,77	0,82	0,84	0,87	0,89	0,91	0,98	1,00														
A		0,73	0,79	0,80	0,83	0,85	0,87	0,93	0,95	1,03	1,05	1,07	1,16	1,19	1,25	1,29							
B			0,73	0,75	0,77	0,80	0,81	0,87	0,89	0,96	0,98	1,00	1,08	1,11	1,16	1,20	1,29	1,33	1,40				
C						0,72	0,73	0,79	0,80	0,87	0,88	0,90	0,97	1,00	1,05	1,09	1,16	1,20	1,27				
D												0,80	0,87	0,89	0,94	0,97	1,04	1,07	1,13	1,20	1,27		
E															0,90	0,94	1,00	1,03	1,09	1,15	1,23	1,25	
20										0,91	0,93	0,95	1,02	1,05	1,10	1,14	1,22						
25										0,82	0,83	0,85	0,92	0,95	1,00	1,03	1,10	1,13					

TABLE 5 - INSTALLATION AND TAKE UP ALLOWANCE									
L (mm)	Y (mm)							X (mm)	
	Z	A	B	C	D	E	20		25
500 / 1000	15	19	25						25
1001 / 1500	15	19	25	38				38	38
1501 / 2500	19	19	32	38				38	51
2501 / 3000		25	32	38				38	63
3001 / 4000		25	38	38	51			38	75
4001 / 5000				51	51	63		51	90
5001 / 6000				51	51	63		51	101
6001 / 7000				51	63	63		51	113
7001 / 8500				51	63	76		51	127
8501 / 10500				51	63	76		51	152
> 10501					76	90		76	1,5% L

# CLASSICAL WRAPPED BELTS

## EXTRA

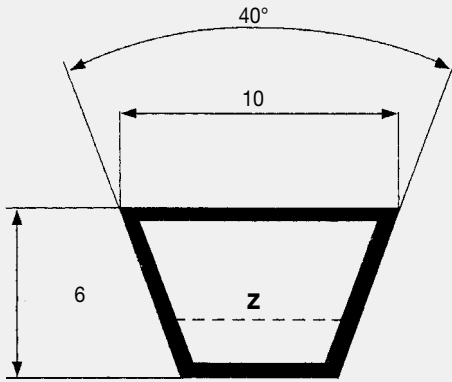

Z SECTION	
CODE	INTERNAL LENGTH LI (mm)
Z 16	410
Z 18	460
Z 19	480
Z 19 1/2	500
Z 20	508
Z 20 1/2	520
Z 21	530
Z 21 1/4	540
Z 21 1/2	545
Z 21 3/4	555
Z 22	560
Z 22 1/4	565
Z 22 1/2	575
Z 23	585
Z 23 1/2	600
Z 23 3/4	605
Z 24	610
Z 24 3/4	630
Z 25	635
Z 25 1/2	650
Z 26	660
Z 26 1/2	670
Z 27	685
Z 27 1/2	700
Z 28	710
Z 28 1/2	725
Z 29	735
Z 29 1/2	750
Z 30	765
Z 30 1/2	775
Z 30 3/4	785
Z 31	787
Z 31 1/2	800
Z 32	815

Z SECTION	
CODE	INTERNAL LENGTH LI (mm)
Z 32 1/2	825
Z 33	840
Z 33 1/2	850
Z 34	865
Z 34 1/2	875
Z 34 1/4	870
Z 35	890
Z 35 1/2	900
Z 36	915
Z 36 1/2	925
Z 36 3/4	935
Z 37	945
Z 37 1/2	950
Z 38	965
Z 38 1/4	975
Z 38 1/2	978
Z 39	1000
Z 40	1016
Z 40 1/2	1030
Z 41	1040
Z 41 1/2	1050
Z 41 3/4	1060
Z 42	1070
Z 42 1/2	1080
Z 43	1090
Z 43 1/4	1100
Z 44	1120
Z 45	1145
Z 46	1180
Z 47	1194
Z 47 3/4	1215
Z 48	1225
Z 48 1/2	1232
Z 49	1245

Z SECTION	
CODE	INTERNAL LENGTH LI (mm)
Z 50	1270
Z 50 1/2	1285
Z 51	1300
Z 52	1320
Z 53	1345
Z 54	1371
Z 55	1400
Z 56	1422
Z 57	1450
Z 58	1473
Z 59	1500
Z 59 1/2	1515
Z 60	1525
Z 61	1550
Z 62	1575
Z 63	1600
Z 64	1625
Z 65	1651
Z 66	1675
Z 67	1700
Z 68	1727
Z 68 1/2	1740
Z 69	1750
Z 70	1778
Z 71	1803
Z 73	1855
Z 75	1905
Z 78	1982
Z 79	2007
Z 83 1/2	2100
Z 88	2235
Z 93	2360
Z 98	2489

# CLASSICAL WRAPPED BELTS

## EXTRA

**TABLE 4 -  $P_b$  (kW) referred to  $\varnothing$  (mm)**

RPM / $\varnothing$	60	63	67	71	75	80	85	90	95	100	106	112	118	125	132	140	150
100	0,10	0,10	0,12	0,13	0,14	0,15	0,17	0,18	0,20	0,21	0,23	0,25	0,26	0,28	0,30	0,32	0,35
200	0,17	0,19	0,21	0,23	0,25	0,28	0,31	0,34	0,36	0,39	0,42	0,45	0,49	0,52	0,56	0,60	0,65
500	0,36	0,40	0,45	0,50	0,56	0,62	0,68	0,74	0,81	0,87	0,94	1,01	1,09	1,17	1,25	1,35	1,47
700	0,48	0,53	0,60	0,67	0,74	0,82	0,91	0,99	1,07	1,16	1,26	1,36	1,45	1,57	1,68	1,81	1,97
900	0,58	0,65	0,73	0,82	0,91	1,01	1,12	1,22	1,33	1,43	1,56	1,68	1,80	1,94	2,09	2,25	2,44
1.000	0,63	0,70	0,80	0,89	0,99	1,10	1,22	1,34	1,45	1,57	1,70	1,84	1,97	2,13	2,28	2,46	2,67
1.400	0,81	0,91	1,04	1,17	1,29	1,45	1,61	1,76	1,92	2,07	2,25	2,43	2,61	2,82	3,02	3,25	3,54
1.500	0,85	0,96	1,10	1,23	1,37	1,53	1,70	1,86	2,03	2,19	2,38	2,57	2,76	2,98	3,20	3,44	3,74
1.700	0,94	1,05	1,21	1,36	1,51	1,69	1,88	2,06	2,24	2,42	2,64	2,85	3,06	3,30	3,54	3,80	4,13
1.800	0,98	1,10	1,26	1,42	1,58	1,77	1,97	2,16	2,35	2,54	2,76	2,98	3,20	3,45	3,70	3,98	4,32
2.500	1,23	1,39	1,60	1,81	2,02	2,27	2,53	2,78	3,02	3,27	3,55	3,83	4,11	4,43	4,74	5,08	5,50
2.900	1,35	1,53	1,77	2,01	2,24	2,53	2,81	3,09	3,37	3,63	3,95	4,26	4,56	4,91	5,24	5,61	6,05
3.000	1,38	1,57	1,81	2,06	2,30	2,59	2,88	3,17	3,45	3,72	4,04	4,36	4,67	5,02	5,35	5,73	6,17
3.500	1,51	1,72	2,00	2,27	2,54	2,87	3,19	3,51	3,82	4,12	4,47	4,81	5,14	5,51	5,86	6,24	6,68
3.600	1,54	1,75	2,04	2,31	2,59	2,92	3,25	3,57	3,88	4,19	4,55	4,89	5,22	5,59	5,94	6,32	6,76
4.000	1,63	1,86	2,16	2,46	2,76	3,12	3,47	3,80	4,13	4,45	4,82	5,18	5,51	5,89	6,23	6,60	
5.000	1,79	2,06	2,42	2,76	3,09	3,49	3,87	4,24	4,59	4,92	5,29	5,64					
6.000	1,88	2,17	2,56	2,93	3,28	3,70	4,09	4,45	4,78								

**$P_d$  (kW) referred to  $i$**

RPM / $i$	1,00/1,01	1,02/1,03	1,04/1,06	1,07/1,08	1,09/1,12	1,13/1,16	1,17/1,22	1,23/1,32	1,33/1,50	OVER 1,51
100	0,00	0,00	0,00	0,00	0,00	0,00	0,00	0,00	0,00	0,00
200	0,00	0,00	0,00	0,00	0,00	0,00	0,00	0,01	0,01	0,01
500	0,00	0,00	0,00	0,01	0,01	0,01	0,01	0,01	0,02	0,02
700	0,00	0,00	0,01	0,01	0,01	0,01	0,02	0,02	0,02	0,03
900	0,00	0,00	0,01	0,01	0,01	0,02	0,02	0,03	0,03	0,03
1.000	0,00	0,00	0,01	0,01	0,02	0,02	0,02	0,03	0,03	0,04
1.400	0,00	0,01	0,01	0,02	0,02	0,03	0,03	0,04	0,05	0,05
1.500	0,00	0,01	0,01	0,02	0,02	0,03	0,04	0,04	0,05	0,05
1.700	0,00	0,01	0,01	0,02	0,03	0,03	0,04	0,05	0,05	0,06
1.800	0,00	0,01	0,01	0,02	0,03	0,04	0,04	0,05	0,06	0,07
2.500	0,00	0,01	0,02	0,03	0,04	0,05	0,06	0,07	0,08	0,09
2.900	0,00	0,01	0,02	0,04	0,05	0,06	0,07	0,08	0,09	0,10
3.000	0,00	0,01	0,02	0,04	0,05	0,06	0,07	0,08	0,10	0,11
3.500	0,00	0,01	0,03	0,04	0,06	0,07	0,08	0,10	0,11	0,13
3.600	0,00	0,01	0,03	0,04	0,06	0,07	0,09	0,10	0,12	0,13
4.000	0,00	0,02	0,03	0,05	0,06	0,08	0,10	0,11	0,13	0,14
5.000	0,00	0,02	0,04	0,06	0,08	0,10	0,12	0,14	0,16	0,18
6.000	0,00	0,02	0,05	0,07	0,10	0,12	0,15	0,17	0,19	0,22

Belt speed is greater than 30 m/s then is necessary to use dynamically balanced pulleys. A reduction in belt life can be expected. Suggested a smaller section.

# CLASSICAL WRAPPED BELTS

## OLEOSTATIC GOLD

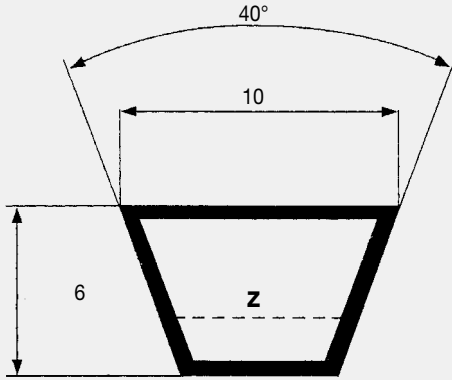

Z SECTION	
CODE	INTERNAL LENGTH LI (mm)
Z 16	410
Z 18	460
Z 19	480
Z 19 1/2	500
Z 20	508
Z 20 1/2	520
Z 21	530
Z 21 1/4	540
Z 21 1/2	545
Z 21 3/4	555
Z 22	560
Z 22 1/4	565
Z 22 1/2	575
Z 23	585
Z 23 1/2	600
Z 23 3/4	605
Z 24	610
Z 24 3/4	630
Z 25	635
Z 25 1/2	650
Z 26	660
Z 26 1/2	670
Z 27	685
Z 27 1/2	700
Z 28	710
Z 28 1/2	725
Z 29	735
Z 29 1/2	750
Z 30	765
Z 30 1/2	775
Z 30 3/4	785
Z 31	787
Z 31 1/2	800
Z 32	815

Z SECTION	
CODE	INTERNAL LENGTH LI (mm)
Z 32 1/2	825
Z 33	840
Z 33 1/2	850
Z 34	865
Z 34 1/2	875
Z 34 1/4	870
Z 35	890
Z 35 1/2	900
Z 36	915
Z 36 1/2	925
Z 36 3/4	935
Z 37	945
Z 37 1/2	950
Z 38	965
Z 38 1/4	975
Z 38 1/2	978
Z 39	1000
Z 40	1016
Z 40 1/2	1030
Z 41	1040
Z 41 1/2	1050
Z 41 3/4	1060
Z 42	1070
Z 42 1/2	1080
Z 43	1090
Z 43 1/4	1100
Z 44	1120
Z 45	1145
Z 46	1180
Z 47	1194
Z 47 3/4	1215
Z 48	1225
Z 48 1/2	1232
Z 49	1245

Z SECTION	
CODE	INTERNAL LENGTH LI (mm)
Z 50	1270
Z 50 1/2	1285
Z 51	1300
Z 52	1320
Z 53	1345
Z 54	1371
Z 55	1400
Z 56	1422
Z 57	1450
Z 58	1473
Z 59	1500
Z 59 1/2	1515
Z 60	1525
Z 61	1550
Z 62	1575
Z 63	1600
Z 64	1625
Z 65	1651
Z 66	1675
Z 67	1700
Z 68	1727
Z 68 1/2	1740
Z 69	1750
Z 70	1778
Z 71	1803
Z 73	1855
Z 75	1905
Z 78	1982
Z 79	2007
Z 83 1/2	2100
Z 88	2235
Z 93	2360
Z 98	2489

# CLASSICAL WRAPPED BELTS

## OLEOSTATIC GOLD

**TABLE 4 - P<sub>b</sub> (kW) referred to Ø (mm)**

RPM / Ø	40	45	50	56	63	71	80	85	90	95	100	106	112	125	132	140	150
100	0,03	0,04	0,05	0,06	0,07	0,09	0,11	0,12	0,13	0,14	0,14	0,16	0,17	0,19	0,21	0,22	0,24
200	0,05	0,07	0,09	0,11	0,13	0,16	0,20	0,22	0,24	0,25	0,27	0,29	0,32	0,36	0,39	0,42	0,45
300	0,06	0,09	0,12	0,15	0,19	0,24	0,28	0,31	0,34	0,36	0,39	0,42	0,46	0,52	0,56	0,60	0,65
400	0,08	0,12	0,15	0,20	0,25	0,30	0,37	0,40	0,44	0,47	0,51	0,55	0,59	0,68	0,73	0,78	0,85
500	0,09	0,14	0,18	0,24	0,30	0,37	0,45	0,49	0,53	0,58	0,62	0,67	0,72	0,83	0,89	0,95	1,04
600	0,10	0,16	0,21	0,28	0,35	0,43	0,52	0,58	0,63	0,68	0,73	0,79	0,85	0,98	1,04	1,12	1,22
700	0,12	0,18	0,24	0,31	0,40	0,49	0,60	0,66	0,72	0,78	0,83	0,90	0,97	1,12	1,20	1,29	1,4
800	0,13	0,20	0,27	0,35	0,45	0,55	0,67	0,74	0,81	0,87	0,94	1,02	1,09	1,26	1,35	1,45	1,57
900	0,14	0,22	0,29	0,39	0,49	0,61	0,75	0,82	0,89	0,97	1,04	1,13	1,21	1,40	1,49	1,61	1,74
1000	0,15	0,23	0,32	0,42	0,54	0,67	0,82	0,90	0,98	1,06	1,14	1,23	1,33	1,53	1,64	1,76	1,91
1200	0,17	0,27	0,37	0,49	0,63	0,78	0,96	1,05	1,15	1,24	1,33	1,45	1,56	1,79	1,92	2,06	2,23
1400	0,18	0,30	0,41	0,55	0,71	0,89	1,09	1,20	1,31	1,41	1,52	1,65	1,77	2,04	2,18	2,34	2,54
1600	0,20	0,33	0,46	0,61	0,79	0,99	1,22	1,34	1,46	1,58	1,70	1,84	1,98	2,28	2,44	2,62	2,83
1800	0,21	0,35	0,50	0,67	0,87	1,10	1,34	1,48	1,61	1,74	1,88	2,03	2,18	2,51	2,68	2,87	3,11
2000	0,22	0,38	0,54	0,73	0,95	1,19	1,46	1,61	1,76	1,90	2,04	2,21	2,38	2,73	2,91	3,11	3,36
2400	0,24	0,43	0,62	0,84	1,09	1,38	1,69	1,86	2,03	2,19	2,35	2,54	2,73	3,12	3,33	3,55	3,82
2800	0,25	0,47	0,68	0,94	1,22	1,55	1,90	2,09	2,27	2,46	2,64	2,84	3,05	3,47	3,68	3,91	4,18
3200	0,26	0,50	0,74	1,03	1,35	1,70	2,09	2,29	2,50	2,69	2,88	3,11	3,32	3,75	3,97	4,20	4,46
3500	0,26	0,53	0,78	1,09	1,43	1,81	2,22	2,43	2,65	2,85	3,05	3,28	3,49	3,92	4,13	4,35	4,59
4000	0,26	0,56	0,84	1,18	1,55	1,97	2,40	2,64	2,86	3,07	3,27	3,50	3,72	4,12	4,31	4,49	4,67
4600	0,26	0,58	0,90	1,27	1,68	2,12	2,59	2,82	3,05	3,26	3,46	3,68	3,87	4,21	4,34	4,44	
5000	0,24	0,59	0,93	1,32	1,75	2,20	2,67	2,91	3,14	3,34	3,53	3,72	3,89	4,15	4,23		

**P<sub>d</sub> (kW) referred to i**

RPM / I	1,00 / 1,01	1,02 / 1,03	1,04 / 1,06	1,07 / 1,08	1,09 / 1,12	1,13 / 1,16	1,17 / 1,22	1,23 / 1,32	1,33 / 1,50	OVER 1,51
100	0,00	0,00	0,00	0,00	0,00	0,00	0,00	0,00	0,00	0,00
200	0,00	0,00	0,00	0,00	0,00	0,00	0,01	0,01	0,01	0,01
300	0,00	0,00	0,00	0,00	0,00	0,01	0,01	0,01	0,01	0,01
400	0,00	0,00	0,00	0,01	0,01	0,01	0,01	0,01	0,02	0,02
500	0,00	0,00	0,00	0,01	0,01	0,01	0,01	0,02	0,02	0,02
600	0,00	0,00	0,01	0,01	0,01	0,01	0,02	0,02	0,02	0,03
700	0,00	0,00	0,01	0,01	0,01	0,02	0,02	0,02	0,03	0,03
800	0,00	0,00	0,01	0,01	0,02	0,02	0,02	0,03	0,03	0,04
900	0,00	0,00	0,01	0,01	0,02	0,02	0,03	0,03	0,04	0,04
1000	0,00	0,00	0,01	0,01	0,02	0,02	0,03	0,03	0,04	0,04
1200	0,00	0,01	0,01	0,02	0,02	0,03	0,04	0,04	0,05	0,05
1400	0,00	0,01	0,01	0,02	0,03	0,03	0,04	0,05	0,06	0,06
1600	0,00	0,01	0,02	0,02	0,03	0,04	0,05	0,06	0,06	0,07
1800	0,00	0,01	0,02	0,03	0,04	0,04	0,05	0,06	0,07	0,08
2000	0,00	0,01	0,02	0,03	0,04	0,05	0,06	0,07	0,08	0,09
2400	0,00	0,01	0,02	0,04	0,05	0,06	0,07	0,08	0,09	0,11
2800	0,00	0,01	0,03	0,04	0,06	0,07	0,08	0,10	0,11	0,12
3200	0,00	0,02	0,03	0,05	0,06	0,08	0,10	0,11	0,13	0,14
3500	0,00	0,02	0,03	0,05	0,07	0,09	0,10	0,12	0,14	0,16
4000	0,00	0,02	0,04	0,06	0,08	0,10	0,12	0,14	0,16	0,18
4600	0,00	0,02	0,05	0,07	0,09	0,11	0,14	0,16	0,18	0,20
5000	0,00	0,02	0,05	0,07	0,10	0,12	0,15	0,17	0,20	0,22

\* Belt speed is greater than 30 m/s then is necessary to use dynamically balanced pulleys. A reduction in belt life can be expected. Suggested a smaller section.

# CLASSICAL WRAPPED BELTS

## EXTRA A SECTION

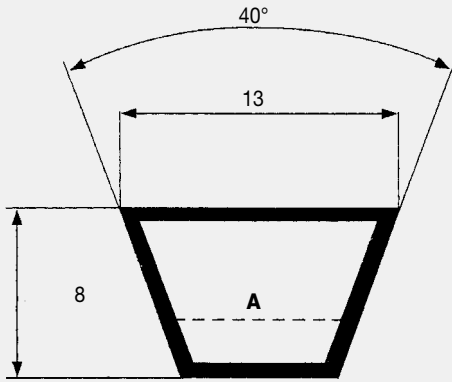

A SECTION	
CODE	INTERNAL LENGTH LI (mm)
A 18	457
A 19	480
A 20	508
A 21	535
A 21 3/4	552
A 22	560
A 23	587
A 23 1/2	600
A 24	610
A 24 1/2	620
A 24 3/4	630
A 25	637
A 25 1/2	647
A 26	660
A 26 1/2	670
A 27	686
A 27 1/2	700
A 28	710
A 28 1/2	724
A 29	737
A 29 1/2	750
A 30	767
A 30 1/2	775
A 31	787
A 31 1/2	800
A 32	813
A 32 1/2	825
A 33	838
A 33 1/4	847
A 33 1/2	850
A 34	867
A 34 1/2	875
A 35	900
A 35 1/2	902
A 36	914
A 36 1/2	925
A 37	942
A 37 1/4	946
A 37 1/2	950
A 38	965
A 38 1/2	975
A 39	992
A 39 1/2	1000
A 40	1016
A 40 1/2	1030
A 41	1041
A 41 1/2	1050
A 41 3/4	1060
A 42	1067
A 42 1/2	1075
A 43	1100
A 43 1/2	1105

A SECTION	
CODE	INTERNAL LENGTH LI (mm)
A 43 3/4	1111
A 44	1120
A 44 1/2	1132
A 45	1143
A 45 1/2	1150
A 46	1168
A 46 1/2	1180
A 47	1200
A 47 1/2	1207
A 48	1220
A 48 1/4	1225
A 48 1/2	1232
A 49	1250
A 50	1270
A 51	1300
A 51 1/2	1307
A 52	1320
A 52 1/2	1337
A 53	1346
A 53 1/4	1355
A 54	1372
A 55	1400
A 56	1422
A 57	1450
A 58	1475
A 59	1500
A 60	1525
A 61	1550
A 62	1575
A 63	1600
A 64	1625
A 65	1650
A 66	1676
A 67	1700
A 68	1725
A 69	1750
A 70	1775
A 70 3/4	1780
A 71	1800
A 72	1825
A 73	1854
A 74	1880
A 75	1900
A 76	1930
A 77	1956
A 78	1980
A 79	2000
A 80	2032
A 81	2060
A 82	2083
A 83	2100
A 83 1/2	2120

A SECTION	
CODE	INTERNAL LENGTH LI (mm)
A 84	2134
A 84 1/2	2146
A 85	2160
A 86	2187
A 86 1/2	2200
A 87	2212
A 88	2240
A 89	2267
A 90	2286
A 91	2311
A 92	2337
A 93	2360
A 94	2388
A 95	2413
A 96	2438
A 97	2464
A 97 1/2	2475
A 98	2500
A 100	2540
A 102	2591
A 104	2650
A 105	2667
A 107	2725
A 108	2743
A 110	2800
A 112	2845
A 113	2870
A 114	2896
A 116	2946
A 118	3000
A 120	3048
A 124	3150
A 128	3250
A 130	3302
A 132	3350
A 134	3404
A 136	3454
A 140	3550
A 144	3658
A 147	3737
A 148	3750
A 155	3937
A 158	4000
A 162	4115
A 167	4250
A 173	4394
A 177	4500
A 180	4572
A 187	4750
A 197	5000
A 210	5334
A 217	5477

# CLASSICAL WRAPPED BELTS

## EXTRA A SECTION

**TABLE 4 -  $P_b$  (kW) referred to  $\emptyset$  (mm)**

RPM / $\emptyset$	90	95	100	106	112	118	125	132	140	150	160	170	180	190	212	220
100	0,23	0,26	0,28	0,30	0,33	0,36	0,39	0,42	0,45	0,49	0,54	0,58	0,62	0,66	0,75	0,79
200	0,42	0,46	0,50	0,55	0,60	0,65	0,71	0,77	0,83	0,91	0,99	1,07	1,15	1,23	1,40	1,46
500	0,90	1,00	1,09	1,21	1,32	1,44	1,57	1,70	1,84	2,03	2,21	2,39	2,57	2,75	3,14	3,28
700	1,19	1,32	1,44	1,60	1,75	1,90	2,08	2,26	2,46	2,70	2,95	3,19	3,43	3,67	4,19	4,38
900	1,45	1,61	1,77	1,96	2,16	2,35	2,57	2,79	3,03	3,34	3,64	3,95	4,24	4,54	5,18	5,41
1.000	1,57	1,75	1,93	2,14	2,35	2,56	2,80	3,04	3,31	3,65	3,98	4,31	4,63	4,95	5,65	5,90
1.400	2,03	2,27	2,51	2,79	3,07	3,35	3,67	3,99	4,35	4,79	5,22	5,65	6,08	6,49	7,38	7,70
1.500	2,14	2,39	2,65	2,95	3,24	3,54	3,87	4,21	4,59	5,06	5,51	5,97	6,41	6,84	7,77	8,10
1.700	2,35	2,63	2,91	3,24	3,57	3,89	4,27	4,64	5,05	5,57	6,07	6,56	7,04	7,51	8,51	8,86
1.800	2,44	2,74	3,03	3,38	3,72	4,06	4,45	4,84	5,28	5,81	6,33	6,84	7,34	7,83	8,85	9,21
2.500	3,05	3,44	3,82	4,26	4,70	5,13	5,62	6,10	6,64	7,29	7,91	8,51	9,08	9,63	10,73	11,09
2.900	3,34	3,77	4,19	4,68	5,16	5,63	6,17	6,68	7,26	7,94	8,59	9,20	9,78	10,31	11,33	11,65
3.000	3,41	3,84	4,27	4,77	5,27	5,74	6,29	6,81	7,39	8,08	8,73	9,34	9,91	10,43	11,42	11,72
3.500	3,69	4,17	4,64	5,18	5,71	6,23	6,80	7,35	7,94	8,63	9,26	9,84	10,34	10,78		
3.600	3,74	4,23	4,70	5,25	5,79	6,30	6,88	7,43	8,02	8,71	9,33	9,89	10,38			
4.000	3,90	4,41	4,91	5,49	6,04	6,56	7,14	7,69	8,26	8,91	9,47					
5.000	4,08	4,63														

**$P_a$  (kW) referred to  $i$**

RPM / $i$	1,00/1,01	1,02/1,03	1,04/1,06	1,07/1,08	1,09/1,12	1,13/1,16	1,17/1,22	1,23/1,32	1,33/1,50	OVER 1,51
100	0,00	0,00	0,00	0,00	0,01	0,01	0,01	0,01	0,01	0,01
200	0,00	0,00	0,01	0,01	0,01	0,02	0,02	0,02	0,03	0,03
500	0,00	0,01	0,02	0,02	0,03	0,04	0,05	0,06	0,07	0,07
700	0,00	0,01	0,02	0,03	0,05	0,06	0,07	0,08	0,09	0,10
900	0,00	0,01	0,03	0,04	0,06	0,07	0,09	0,10	0,12	0,13
1.000	0,00	0,02	0,03	0,05	0,07	0,08	0,10	0,11	0,13	0,15
1.400	0,00	0,02	0,05	0,07	0,09	0,11	0,14	0,16	0,18	0,21
1.500	0,00	0,02	0,05	0,07	0,10	0,12	0,15	0,17	0,20	0,22
1.700	0,00	0,03	0,06	0,08	0,11	0,14	0,17	0,20	0,22	0,25
1.800	0,00	0,03	0,06	0,09	0,12	0,15	0,18	0,21	0,24	0,26
2.500	0,00	0,04	0,08	0,12	0,16	0,20	0,25	0,29	0,33	0,37
2.900	0,00	0,05	0,09	0,14	0,19	0,24	0,29	0,33	0,38	0,43
3.000	0,00	0,05	0,10	0,15	0,20	0,24	0,30	0,34	0,39	0,44
3.500	0,00	0,06	0,11	0,17	0,23	0,29	0,35	0,40	0,46	0,51
3.600	0,00	0,06	0,12	0,18	0,24	0,29	0,36	0,41	0,47	0,53
4.000	0,00	0,07	0,13	0,20	0,26	0,33	0,39	0,46	0,52	0,59
5.000	0,00	0,08	0,16	0,25	0,33	0,41	0,49	0,57	0,65	0,74

Belt speed is greater than 30 m/s then is necessary to use dynamically balanced pulleys. A reduction in belt life can be expected. Suggested a smaller section.

# CLASSICAL WRAPPED BELTS

## OLEOSTATIC GOLD A SECTION

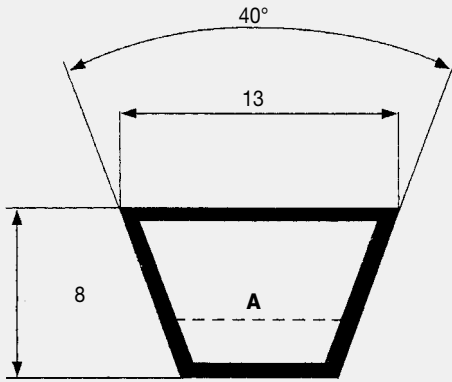

A SECTION	
CODE	INTERNAL LENGTH LI (mm)
A 18	457
A 19	480
A 20	508
A 21	535
A 21 3/4	552
A 22	560
A 23	587
A 23 1/2	600
A 24	610
A 24 1/2	620
A 24 3/4	630
A 25	637
A 25 1/2	647
A 26	660
A 26 1/2	670
A 27	686
A 27 1/2	700
A 28	710
A 28 1/2	724
A 29	737
A 29 1/2	750
A 30	767
A 30 1/2	775
A 31	787
A 31 1/2	800
A 32	813
A 32 1/2	825
A 33	838
A 33 1/4	847
A 33 1/2	850
A 34	867
A 34 1/2	875
A 35	900
A 35 1/2	902
A 36	914
A 36 1/2	925
A 37	942
A 37 1/4	946
A 37 1/2	950
A 38	965
A 38 1/2	975
A 39	992
A 39 1/2	1000
A 40	1016
A 40 1/2	1030
A 41	1041
A 41 1/2	1050
A 41 3/4	1060
A 42	1067
A 42 1/2	1075
A 43	1100
A 43 1/2	1105

A SECTION	
CODE	INTERNAL LENGTH LI (mm)
A 43 3/4	1111
A 44	1120
A 44 1/2	1132
A 45	1143
A 45 1/2	1150
A 46	1168
A 46 1/2	1180
A 47	1200
A 47 1/2	1207
A 48	1220
A 48 1/4	1225
A 48 1/2	1232
A 49	1250
A 50	1270
A 51	1300
A 51 1/2	1307
A 52	1320
A 52 1/2	1337
A 53	1346
A 53 1/4	1355
A 54	1372
A 55	1400
A 56	1422
A 57	1450
A 58	1475
A 59	1500
A 60	1525
A 61	1550
A 62	1575
A 63	1600
A 64	1625
A 65	1650
A 66	1676
A 67	1700
A 68	1725
A 69	1750
A 70	1775
A 70 3/4	1780
A 71	1800
A 72	1825
A 73	1854
A 74	1880
A 75	1900
A 76	1930
A 77	1956
A 78	1980
A 79	2000
A 80	2032
A 81	2060
A 82	2083
A 83	2100
A 83 1/2	2120

A SECTION	
CODE	INTERNAL LENGTH LI (mm)
A 84	2134
A 84 1/2	2146
A 85	2160
A 86	2187
A 86 1/2	2200
A 87	2212
A 88	2240
A 89	2267
A 90	2286
A 91	2311
A 92	2337
A 93	2360
A 94	2388
A 95	2413
A 96	2438
A 97	2464
A 97 1/2	2475
A 98	2500
A 100	2540
A 102	2591
A 104	2650
A 105	2667
A 107	2725
A 108	2743
A 110	2800
A 112	2845
A 113	2870
A 114	2896
A 116	2946
A 118	3000
A 120	3048
A 124	3150
A 128	3250
A 130	3302
A 132	3350
A 134	3404
A 136	3454
A 140	3550
A 144	3658
A 147	3737
A 148	3750
A 155	3937
A 158	4000
A 162	4115
A 167	4250
A 173	4394
A 177	4500
A 187	4750
A 197	5000
A 210	5334
A 217	5477

# CLASSICAL WRAPPED BELTS

## OLEOSTATIC GOLD A SECTION

**TABLE 4 -  $P_b$  (kW) referred to  $\emptyset$  (mm)**

RPM / $\emptyset$	71	80	85	90	95	100	106	112	125	132	140	150	160	170	180	190	200	212
100	0,15	0,19	0,22	0,24	0,27	0,29	0,32	0,35	0,42	0,45	0,49	0,54	0,58	0,63	0,68	0,73	0,77	0,83
200	0,25	0,34	0,39	0,43	0,48	0,53	0,58	0,64	0,76	0,82	0,90	0,99	1,08	1,16	1,25	1,34	1,43	1,53
300	0,34	0,47	0,54	0,61	0,67	0,74	0,82	0,90	1,07	1,17	1,27	1,40	1,53	1,66	1,79	1,91	2,04	2,19
400	0,42	0,59	0,68	0,76	0,85	0,94	1,04	1,15	1,37	1,49	1,63	1,79	1,96	2,13	2,29	2,46	2,62	2,81
500	0,50	0,70	0,80	0,91	1,02	1,13	1,25	1,38	1,65	1,80	1,96	2,17	2,37	2,58	2,78	2,98	3,17	3,41
600	0,56	0,80	0,93	1,05	1,18	1,31	1,46	1,60	1,93	2,10	2,29	2,53	2,77	3,01	3,24	3,48	3,71	3,98
700	0,63	0,89	1,04	1,19	1,33	1,48	1,65	1,82	2,19	2,38	2,60	2,88	3,15	3,42	3,69	3,96	4,22	4,54
800	0,68	0,98	1,15	1,31	1,48	1,64	1,83	2,03	2,44	2,66	2,91	3,22	3,52	3,83	4,13	4,43	4,72	5,07
900	0,73	1,07	1,25	1,44	1,62	1,80	2,01	2,23	2,68	2,93	3,20	3,55	3,88	4,22	4,55	4,88	5,2	5,59
1000	0,78	1,15	1,35	1,55	1,75	1,95	2,19	2,42	2,92	3,19	3,49	3,86	4,23	4,60	4,96	5,31	5,67	6,08
1200	0,87	1,30	1,54	1,78	2,01	2,24	2,52	2,79	3,37	3,68	4,03	4,47	4,90	5,32	5,73	6,14	6,55	7,03
1400	0,95	1,44	1,71	1,98	2,25	2,51	2,82	3,14	3,80	4,15	4,55	5,04	5,52	5,99	6,46	6,91	7,36	7,89
1600	1,01	1,57	1,87	2,17	2,47	2,76	3,11	3,46	4,20	4,59	5,03	5,57	6,10	6,62	7,13	7,63	8,11	8,68
1800	1,07	1,68	2,02	2,35	2,68	3,00	3,39	3,77	4,57	5,00	5,48	6,07	6,64	7,20	7,74	8,28	8,79	9,39
2000	1,12	1,79	2,15	2,51	2,87	3,22	3,64	4,05	4,92	5,38	5,90	6,52	7,13	7,73	8,30	8,86	9,4	10,01
2400	1,19	1,96	2,38	2,80	3,21	3,61	4,09	4,56	5,55	6,06	6,63	7,32	7,99	8,63	9,24	9,82	10,36	10,98
2800	1,22	2,10	2,57	3,03	3,49	3,94	4,47	4,99	6,06	6,62	7,23	7,96	8,65	9,30	9,90	10,46	10,98	11,53
3200	1,23	2,19	2,71	3,22	3,71	4,20	4,77	5,32	6,46	7,04	7,67	8,41	9,09	9,71	10,27	10,77	11,2	
3500	1,21	2,23	2,78	3,32	3,84	4,35	4,94	5,52	6,68	7,27	7,89	8,62	9,27	9,84	10,34	10,75		
4000	1,13	2,24	2,84	3,41	3,97	4,51	5,12	5,71	6,88	7,45	8,04	8,70	9,24					
4600	0,98	2,17	2,80	3,40	3,98	4,53	5,15	5,73	6,83	7,34	7,83							
5000	0,82	2,06	2,70	3,32	3,89	4,44	5,05	5,60	6,61	7,03								

**$P_d$  (kW) referred to i**

RPM / i	1,00 / 1,01	1,02 / 1,03	1,04 / 1,06	1,07 / 1,08	1,09 / 1,12	1,13 / 1,16	1,17 / 1,22	1,23 / 1,32	1,33 / 1,50	OVER 1,51
100	0,00	0,00	0,00	0,01	0,01	0,01	0,01	0,01	0,02	0,02
200	0,00	0,00	0,01	0,01	0,02	0,02	0,02	0,03	0,03	0,04
300	0,00	0,01	0,01	0,02	0,02	0,03	0,04	0,04	0,05	0,05
400	0,00	0,01	0,02	0,02	0,03	0,04	0,05	0,06	0,06	0,07
500	0,00	0,01	0,02	0,03	0,04	0,05	0,06	0,07	0,08	0,09
600	0,00	0,01	0,02	0,04	0,05	0,06	0,07	0,08	0,10	0,11
700	0,00	0,01	0,03	0,04	0,06	0,07	0,08	0,10	0,11	0,13
800	0,00	0,02	0,03	0,05	0,06	0,08	0,10	0,11	0,13	0,14
900	0,00	0,02	0,04	0,05	0,07	0,09	0,11	0,13	0,14	0,16
1000	0,00	0,02	0,04	0,06	0,08	0,10	0,12	0,14	0,16	0,18
1200	0,00	0,02	0,05	0,07	0,10	0,12	0,14	0,17	0,19	0,21
1400	0,00	0,03	0,06	0,08	0,11	0,14	0,17	0,20	0,22	0,25
1600	0,00	0,03	0,06	0,10	0,13	0,16	0,19	0,22	0,25	0,29
1800	0,00	0,04	0,07	0,11	0,14	0,18	0,22	0,25	0,29	0,32
2000	0,00	0,04	0,08	0,12	0,16	0,20	0,24	0,28	0,32	0,36
2400	0,00	0,05	0,10	0,14	0,19	0,24	0,29	0,34	0,38	0,43
2800	0,00	0,06	0,11	0,17	0,22	0,28	0,34	0,39	0,45	0,50
3200	0,00	0,06	0,13	0,19	0,25	0,32	0,38	0,45	0,51	0,57
3500	0,00	0,07	0,14	0,21	0,28	0,35	0,42	0,49	0,56	0,63
4000	0,00	0,08	0,16	0,24	0,32	0,40	0,48	0,56	0,64	0,72
4600	0,00	0,09	0,18	0,28	0,37	0,46	0,55	0,64	0,73	0,82
5000	0,00	0,10	0,20	0,30	0,40	0,50	0,60	0,70	0,80	0,89

\* Belt speed is greater than 30 m/s then is necessary to use dynamically balanced pulleys. A reduction in belt life can be expected. Suggested a smaller section.

# CLASSICAL WRAPPED BELTS

## EXTRA B SECTION

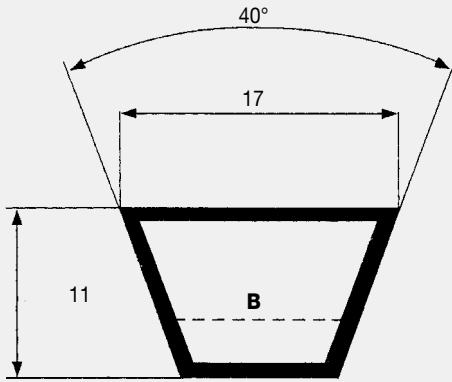

B SECTION	
CODE	INTERNAL LENGTH LI (mm)
B 22 1/2	570
B 23	587
B 24	612
B 25	637
B 26	650
B 26 1/2	673
B 27	686
B 28	710
B 28 1/2	725
B 29	737
B 29 1/2	750
B 30	762
B 30 1/2	775
B 31	787
B 31 1/2	800
B 32	812
B 32 1/4	822
B 32 1/2	825
B 33	838
B 33 1/2	850
B 34	867
B 34 1/2	875
B 35	889
B 35 1/2	900
B 35 3/4	907
B 36	917
B 36 1/2	925
B 36 3/4	937
B 37	942
B 37 1/2	950
B 38	965
B 38 1/2	975
B 39	990
B 39 1/2	1000
B 40	1016
B 40 1/2	1030
B 41	1040
B 41 1/2	1050
B 41 3/4	1060
B 42	1067
B 42 1/2	1075
B 43	1090
B 43 1/4	1096
B 43 1/2	1100
B 44	1120
B 44 1/4	1127
B 45	1142
B 45 1/2	1155
B 46	1175
B 46 1/2	1180
B 46 3/4	1187
B 47	1200
B 47 1/4	1202
B 47 1/2	1215
B 48	1225
B 48 1/2	1232
B 49	1250
B 50	1275
B 51	1300
B 52	1320
B 52 1/2	1336
B 53	1350
B 53 1/2	1360
B 54	1372
B 55	1400
B 55 1/2	1412
B 56	1422
B 57	1450
B 58	1473
B 59	1500
B 60	1525
B 61	1550
B 62	1575
B 63	1600
B 64	1625

B SECTION	
CODE	INTERNAL LENGTH LI (mm)
B 64 1/2	1642
B 65	1650
B 66 1/4	1682
B 66	1676
B 66 1/2	1692
B 67	1700
B 67 1/4	1712
B 68	1725
B 69	1750
B 69 1/2	1761
B 70	1775
B 71	1800
B 72	1829
B 73	1850
B 74	1880
B 75	1900
B 76	1930
B 77	1950
B 78	1981
B 79	2000
B 80	2032
B 80 3/4	2050
B 81	2060
B 82	2083
B 83	2108
B 83 1/2	2120
B 84	2134
B 85	2160
B 86	2187
B 86 1/2	2200
B 87	2215
B 88	2240
B 89	2261
B 90	2286
B 91	2312
B 92	2337
B 93	2360
B 94	2388
B 94 1/2	2400
B 95	2413
B 96	2438
B 96 1/2	2450
B 97	2465
B 97 1/2	2477
B 98	2500
B 99	2515
B 100	2540
B 101	2565
B 102	2600
B 103	2616
B 104	2650
B 105	2667
B 106	2700
B 107	2718
B 108	2750
B 109	2769
B 110	2800
B 112	2845
B 112 1/2	2857
B 114	2900
B 115	2921
B 116	2950
B 118	3000
B 120	3048
B 122	3099
B 124	3150
B 126	3200
B 127	3227
B 128	3250
B 130	3302
B 131	3327
B 132	3350
B 133	3378
B 134	3407
B 135	3429

B SECTION	
CODE	INTERNAL LENGTH LI (mm)
B 136	3450
B 138	3505
B 140	3550
B 142	3607
B 144	3658
B 146	3708
B 147	3737
B 148	3750
B 150	3810
B 151	3850
B 152	3861
B 154	3912
B 155	3950
B 156	3962
B 157	3987
B 158	4000
B 160	4064
B 161	4087
B 162	4115
B 163	4142
B 165	4200
B 167	4250
B 168	4267
B 173	4394
B 175	4450
B 177	4500
B 180	4572
B 186	4727
B 187	4750
B 188	4777
B 192	4877
B 195	4953
B 197	5000
B 204	5182
B 208	5300
B 210	5334
B 217	5507
B 220	5552
B 221	5577
B 223	5632
B 224	5657
B 225	5682
B 228	5757
B 229	5782
B 236	5994
B 237	6000
B 240	6062
B 248	6267
B 249	6287
B 253	6392
B 255	6442
B 256	6502
B 259	6542
B 264	6665
B 265	6700
B 269	6800
B 270	6825
B 276	7000
B 280	7100
B 285	7207
B 300	7587
B 315	7967
B 330	8347
B 345	8727
B 360	9107
B 361	9132
B 364	9207
B 366	9262
B 394	9972
B 433	10957
B 472	11957
B 512	13005
B 551	13995
B 553	14053
B 669	16992

# CLASSICAL WRAPPED BELTS

## EXTRA B SECTION

**TABLE 4 -  $P_b$  (kW) referred to  $\varnothing$  (mm)**

RPM / $\varnothing$	125	132	140	150	160	170	180	190	200	212	224	236	250	280	315
100	0,48	0,53	0,58	0,64	0,71	0,77	0,84	0,90	0,96	1,04	1,11	1,19	1,27	1,46	1,67
200	0,87	0,95	1,05	1,17	1,30	1,42	1,54	1,66	1,77	1,92	2,06	2,20	2,36	2,70	3,10
500	1,86	2,06	2,28	2,56	2,83	3,11	3,38	3,65	3,92	4,24	4,56	4,88	5,24	6,02	6,91
700	2,44	2,70	3,00	3,38	3,75	4,12	4,48	4,85	5,21	5,64	6,06	6,48	6,97	7,99	9,15
900	2,97	3,30	3,67	4,14	4,60	5,06	5,51	5,96	6,40	6,93	7,45	7,96	8,55	9,79	11,19
1.000	3,22	3,58	3,99	4,50	5,00	5,50	5,99	6,48	6,96	7,54	8,10	8,66	9,29	10,63	12,12
1.400	4,13	4,61	5,15	5,82	6,48	7,13	7,76	8,39	9,01	9,73	10,44	11,13	11,92	13,52	15,25
1.500	4,33	4,84	5,41	6,12	6,81	7,49	8,16	8,82	9,46	10,22	10,95	11,67	12,48	14,12	15,86
1.700	4,72	5,28	5,91	6,68	7,44	8,18	8,91	9,61	10,30	11,11	11,89	12,64	13,49	15,16	16,87
1.800	4,90	5,49	6,14	6,95	7,73	8,50	9,25	9,98	10,69	11,51	12,31	13,07	13,93	15,60	17,26
2.500	5,93	6,66	7,46	8,43	9,36	10,24	11,09	11,89	12,64	13,49	14,26	14,95	15,66		
2.900	6,33	7,10	7,95	8,97	9,92	10,82	11,65	12,41	13,11	13,85	14,48				
3.000	6,40	7,18	8,04	9,06	10,02	10,90	11,72	12,47	13,14	13,84					
3.500	6,62	7,42	8,29	9,30	10,20	11,01	11,70	12,29							

**$P_d$  (kW) referred to  $i$**

RPM	1,00/1,01	1,02/1,03	1,04/1,06	1,07/1,08	1,09/1,12	1,13/1,16	1,17/1,22	1,23/1,32	1,33/1,50	OVER 1,51
100	0,00	0,00	0,01	0,01	0,01	0,02	0,02	0,03	0,03	0,03
200	0,00	0,01	0,01	0,02	0,03	0,04	0,04	0,05	0,06	0,06
500	0,00	0,02	0,04	0,05	0,07	0,09	0,11	0,13	0,14	0,16
700	0,00	0,02	0,05	0,08	0,10	0,13	0,15	0,18	0,20	0,23
900	0,00	0,03	0,06	0,10	0,13	0,16	0,19	0,23	0,26	0,29
1.000	0,00	0,04	0,07	0,11	0,14	0,18	0,22	0,25	0,29	0,32
1.400	0,00	0,05	0,10	0,15	0,20	0,25	0,30	0,35	0,40	0,45
1.500	0,00	0,05	0,11	0,16	0,21	0,27	0,32	0,38	0,43	0,48
1.700	0,00	0,06	0,12	0,18	0,24	0,30	0,37	0,43	0,49	0,55
1.800	0,00	0,06	0,13	0,19	0,26	0,32	0,39	0,45	0,52	0,58
2.500	0,00	0,09	0,18	0,27	0,36	0,45	0,54	0,63	0,72	0,81
2.900	0,00	0,10	0,21	0,31	0,42	0,52	0,63	0,73	0,83	0,94
3.000	0,00	0,11	0,22	0,32	0,43	0,54	0,65	0,76	0,86	0,97
3.500	0,00	0,12	0,25	0,38	0,50	0,63	0,76	0,88	1,00	1,13

Belt speed is greater than 30 m/s then is necessary to use dynamically balanced pulleys. A reduction in belt life can be expected. Suggested a smaller section.

# CLASSICAL WRAPPED BELTS

## OLEOSTATIC GOLD B SECTION

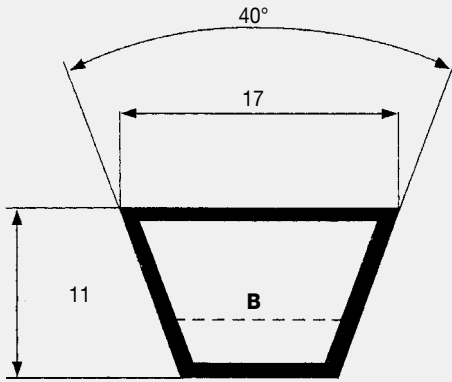

B SECTION	
CODE	INTERNAL LENGTH LI (mm)
B 22 1/2	570
B 23	587
B 24	612
B 25	637
B 26	650
B 26 1/2	673
B 27	686
B 28	710
B 28 1/2	725
B 29	737
B 29 1/2	750
B 30	762
B 30 1/2	775
B 31	787
B 31 1/2	800
B 32	812
B 32 1/4	822
B 32 1/2	825
B 33	838
B 33 1/2	850
B 34	867
B 34 1/2	875
B 35	889
B 35 1/2	900
B 35 3/4	907
B 36	917
B 36 1/2	925
B 36 3/4	937
B 37	942
B 37 1/2	950
B 38	965
B 38 1/2	975
B 39	990
B 39 1/2	1000
B 40	1016
B 40 1/2	1030
B 41	1040
B 41 1/2	1050
B 41 3/4	1060
B 42	1067
B 42 1/2	1075
B 43	1090
B 43 1/2	1100
B 43 1/4	1096
B 44	1120
B 44 1/4	1127
B 45	1142
B 45 1/2	1155
B 46	1175
B 46 1/2	1180
B 46 3/4	1187
B 47	1200
B 47 1/4	1202
B 47 1/2	1215
B 48	1225
B 48 1/2	1232
B 49	1250
B 50	1275
B 51	1300
B 52	1320
B 52 1/2	1335
B 53	1350
B 53 1/2	1360
B 54	1372
B 55	1400
B 55 1/2	1412
B 56	1422
B 57	1450
B 58	1473
B 59	1500
B 60	1525
B 61	1550
B 62	1575
B 63	1600
B 64	1625

B SECTION	
CODE	INTERNAL LENGTH LI (mm)
B 64 1/2	1642
B 65	1650
B 66	1676
B 66 1/4	1682
B 66 1/2	1692
B 67	1700
B 67 1/4	1712
B 68	1725
B 69	1750
B 69 1/2	1761
B 70	1775
B 71	1800
B 72	1829
B 73	1850
B 74	1880
B 75	1900
B 76	1930
B 77	1950
B 78	1981
B 79	2000
B 80	2032
B 80 3/4	2050
B 81	2060
B 82	2083
B 83	2108
B 83 1/2	2120
B 84	2134
B 85	2160
B 86	2187
B 86 1/2	2200
B 87	2215
B 88	2240
B 89	2261
B 90	2286
B 91	2312
B 92	2337
B 93	2360
B 94	2388
B 94 1/2	2400
B 95	2413
B 96	2438
B 96 1/2	2450
B 97	2465
B 97 1/2	2477
B 98	2500
B 99	2515
B 100	2540
B 101	2565
B 102	2600
B 103	2616
B 104	2650
B 105	2667
B 106	2700
B 107	2718
B 108	2750
B 109	2769
B 110	2800
B 112	2845
B 112 1/2	2857
B 114	2900
B 115	2921
B 116	2950
B 118	3000
B 120	3048
B 122	3099
B 124	3150
B 126	3200
B 127	3227
B 128	3250
B 130	3302
B 131	3327
B 132	3350
B 133	3378
B 134	3407
B 135	3429

B SECTION	
CODE	INTERNAL LENGTH LI (mm)
B 136	3450
B 138	3505
B 140	3550
B 142	3607
B 144	3658
B 146	3708
B 147	3737
B 148	3750
B 150	3810
B 151	3850
B 152	3861
B 154	3912
B 155	3950
B 156	3962
B 157	3987
B 158	4000
B 160	4064
B 161	4087
B 162	4115
B 163	4142
B 165	4200
B 167	4250
B 168	4267
B 173	4394
B 175	4450
B 177	4500
B 180	4572
B 186	4727
B 187	4750
B 188	4777
B 192	4877
B 195	4953
B 197	5000
B 204	5182
B 208	5300
B 210	5334
B 217	5507
B 220	5552
B 221	5577
B 223	5632
B 224	5657
B 225	5682
B 228	5757
B 229	5782
B 236	5994
B 237	6000
B 240	6062
B 248	6267
B 249	6287
B 253	6392
B 255	6442
B 256	6502
B 259	6542
B 264	6665
B 265	6700
B 269	6800
B 270	6825
B 276	7000
B 280	7100
B 285	7207
B 300	7587
B 315	7967
B 330	8347
B 345	8727
B 360	9107
B 361	9132
B 364	9207
B 366	9262
B 394	9972
B 433	10957
B 472	11957
B 512	13005
B 551	13995
B 553	14053
B 669	16992

# CLASSICAL WRAPPED BELTS

## OLEOSTATIC GOLD B SECTION

**TABLE 4 - P<sub>b</sub> (kW) referred to Ø (mm)**

RPM / Ø	112	118	132	140	150	160	170	180	190	200	212	224	236	250	265	280
100	0,40	0,44	0,55	0,61	0,69	0,76	0,84	0,91	0,99	1,06	1,15	1,24	1,32	1,42	1,53	1,64
200	0,70	0,78	0,99	1,10	1,24	1,38	1,52	1,66	1,80	1,94	2,11	2,27	2,43	2,62	2,82	3,02
300	0,96	1,08	1,37	1,54	1,74	1,95	2,15	2,35	2,55	2,75	2,99	3,22	3,46	3,73	4,02	4,31
400	1,19	1,35	1,73	1,95	2,21	2,48	2,74	3,00	3,26	3,51	3,82	4,12	4,43	4,78	5,15	5,52
500	1,41	1,61	2,07	2,33	2,65	2,97	3,29	3,61	3,93	4,24	4,61	4,98	5,35	5,77	6,22	6,67
600	1,61	1,84	2,38	2,69	3,07	3,45	3,82	4,20	4,56	4,93	5,37	5,80	6,23	6,72	7,25	7,77
700	1,79	2,06	2,68	3,03	3,47	3,90	4,33	4,75	5,18	5,59	6,09	6,58	7,07	7,63	8,23	8,82
800	1,97	2,27	2,97	3,36	3,85	4,34	4,82	5,29	5,76	6,23	6,78	7,33	7,88	8,50	9,16	9,82
900	2,13	2,47	3,24	3,68	4,22	4,75	5,28	5,81	6,33	6,84	7,45	8,05	8,65	9,33	10,05	10,76
1000	2,28	2,65	3,50	3,98	4,57	5,15	5,73	6,30	6,86	7,42	8,08	8,74	9,38	10,12	10,89	11,66
1200	2,56	2,99	3,98	4,53	5,22	5,90	6,57	7,22	7,87	8,51	9,27	10,01	10,74	11,57	12,44	13,29
1400	2,81	3,29	4,41	5,04	5,82	6,58	7,33	8,06	8,79	9,50	10,33	11,15	11,95	12,85	13,78	14,69
1600	3,02	3,56	4,80	5,50	6,36	7,19	8,02	8,82	9,61	10,38	11,28	12,15	12,99	13,94	14,92	15,84
1800	3,20	3,79	5,15	5,91	6,84	7,74	8,63	9,49	10,33	11,14	12,09	13,00	13,87	14,84	15,81	16,73
2000	3,34	3,99	5,45	6,26	7,26	8,22	9,16	10,06	10,94	11,78	12,76	13,68	14,56	15,52	16,46	17,32
2400	3,54	4,27	5,91	6,81	7,90	8,95	9,96	10,91	11,82	12,68	13,64	14,53	15,33	16,17	16,92	
2800	3,60	4,39	6,17	7,14	8,28	9,37	10,38	11,33	12,21	13,00	13,86	14,59	15,20			
3200	3,52	4,36	6,22	7,21	8,37	9,43	10,40	11,27	12,03	12,68						
3500	3,36	4,23	6,11	7,09	8,22	9,23	10,12	10,87	11,50							
4000	2,90	3,77	5,61	6,53	7,54	8,37										
4600	1,98	2,81	4,46	5,21												

**P<sub>d</sub> (kW) referred to i**

RPM / I	1,00 / 1,01	1,02 / 1,03	1,04 / 1,06	1,07 / 1,08	1,09 / 1,12	1,13 / 1,16	1,17 / 1,22	1,23 / 1,32	1,33 / 1,50	OVER 1,51
100	0,00	0,00	0,01	0,01	0,02	0,02	0,03	0,03	0,04	0,04
200	0,00	0,01	0,02	0,03	0,04	0,04	0,05	0,06	0,07	0,08
300	0,00	0,01	0,03	0,04	0,05	0,07	0,08	0,09	0,11	0,12
400	0,00	0,02	0,04	0,05	0,07	0,09	0,11	0,12	0,14	0,16
500	0,00	0,02	0,04	0,07	0,09	0,11	0,13	0,16	0,18	0,20
600	0,00	0,03	0,05	0,08	0,11	0,13	0,16	0,19	0,21	0,24
700	0,00	0,03	0,06	0,09	0,12	0,15	0,19	0,22	0,25	0,28
800	0,00	0,04	0,07	0,11	0,14	0,18	0,21	0,25	0,28	0,32
900	0,00	0,04	0,08	0,12	0,16	0,20	0,24	0,28	0,32	0,36
1000	0,00	0,04	0,09	0,13	0,18	0,22	0,27	0,31	0,35	0,40
1200	0,00	0,05	0,11	0,16	0,21	0,26	0,32	0,37	0,42	0,48
1400	0,00	0,06	0,12	0,19	0,25	0,31	0,37	0,43	0,49	0,56
1600	0,00	0,07	0,14	0,21	0,28	0,35	0,43	0,50	0,56	0,63
1800	0,00	0,08	0,16	0,24	0,32	0,40	0,48	0,56	0,64	0,71
2000	0,00	0,09	0,18	0,27	0,35	0,44	0,53	0,62	0,71	0,79
2400	0,00	0,11	0,21	0,32	0,42	0,53	0,64	0,74	0,85	0,95
2800	0,00	0,12	0,25	0,37	0,49	0,62	0,74	0,87	0,99	1,11
3200	0,00	0,14	0,28	0,42	0,56	0,70	0,85	0,99	1,13	1,27
3500	0,00	0,15	0,31	0,46	0,62	0,77	0,93	1,09	1,24	1,39
4000	0,00	0,18	0,35	0,53	0,70	0,88	1,06	1,24	1,41	1,59
4600	0,00	0,20	0,41	0,61	0,81	1,01	1,22	1,43	1,62	1,82

\* Belt speed is greater than 30 m/s then is necessary to use dynamically balanced pulleys. A reduction in belt life can be expected. Suggested a smaller section.

# CLASSICAL WRAPPED BELTS

## EXTRA C SECTION

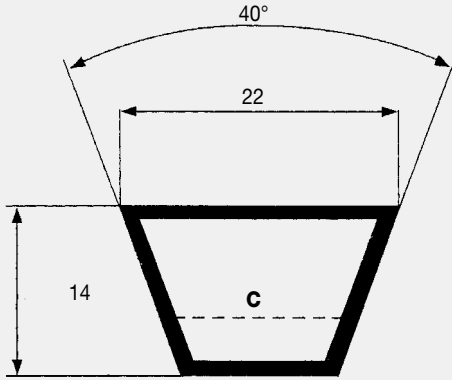

C SECTION	
CODE	INTERNAL LENGTH LI (mm)
C 33 3/4	858
C 37 1/2	950
C 39 3/4	1013
C 43	1090
C 45	1150
C 46	1168
C 47	1194
C 48	1220
C 49	1250
C 51	1295
C 52	1320
C 53	1350
C 54	1372
C 55	1400
C 56	1425
C 57	1450
C 58	1473
C 59	1500
C 60	1524
C 61	1560
C 62	1576
C 62 1/4	1583
C 63	1600
C 65	1650
C 66	1676
C 67	1700
C 68	1727
C 69	1753
C 70	1778
C 71	1798
C 72	1829
C 73	1854
C 74	1879
C 75	1900
C 76	1930
C 77	1955
C 78	1978
C 79	2005
C 80	2032
C 81	2057
C 82	2080
C 83	2108
C 83 1/2	2121
C 84	2134
C 85	2159
C 86	2184
C 87	2208
C 88	2235
C 89	2261

C SECTION	
CODE	INTERNAL LENGTH LI (mm)
C 90	2286
C 92	2337
C 93	2360
C 94	2388
C 95	2413
C 96	2438
C 96 1/2	2450
C 97	2462
C 97 1/2	2477
C 98	2500
C 99	2525
C 100	2540
C 101	2560
C 102	2591
C 104	2642
C 105	2667
C 106	2692
C 108	2750
C 110	2800
C 111	2818
C 112	2845
C 112 1/2	2858
C 114	2888
C 115	2921
C 116	2950
C 117	2965
C 118	3000
C 120	3048
C 122	3099
C 124	3150
C 126	3200
C 128	3250
C 130	3302
C 132	3350
C 134	3404
C 136	3456
C 138	3498
C 140	3550
C 142	3607
C 144	3658
C 147	3733
C 148	3750
C 150	3808
C 153	3902
C 158	4000
C 160	4064
C 161 1/2	4100
C 162	4115
C 165	4193

C SECTION	
CODE	INTERNAL LENGTH LI (mm)
C 166	4216
C 167	4242
C 168	4267
C 170	4318
C 173	4394
C 175	4445
C 177	4500
C 180	4572
C 187	4750
C 190	4826
C 195	4953
C 197	5000
C 204	5182
C 208	5300
C 210	5334
C 216	5486
C 220	5550
C 222	5600
C 225	5678
C 228	5753
C 236	6000
C 238	6045
C 240	6062
C 248	6263
C 250	6300
C 255	6438
C 264	6670
C 265	6700
C 270	6822
C 276	6973
C 280	7100
C 285	7203
C 295	7493
C 297	7500
C 300	7582
C 303	7650
C 314	7976
C 315	7965
C 316	8000
C 320	8093
C 330	8382
C 336	8500
C 345	8723
C 360	9107
C 394	10000
C 420	10632
C 424	10733

# CLASSICAL WRAPPED BELTS

## EXTRA C SECTION

**TABLE 4 -  $P_b$  (kW) referred to  $\emptyset$  (mm)**

RPM / $\emptyset$	180	190	200	212	224	236	250	265	280	300	315	335	355	375	400	425
100	1,08	1,18	1,29	1,41	1,54	1,67	1,81	1,97	2,12	2,32	2,48	2,68	2,88	3,08	3,33	3,58
150	1,52	1,68	1,83	2,01	2,19	2,38	2,59	2,81	3,04	3,33	3,55	3,85	4,14	4,43	4,79	5,15
200	1,94	2,14	2,34	2,58	2,82	3,05	3,33	3,62	3,91	4,30	4,58	4,96	5,34	5,72	6,19	6,65
400	3,45	3,83	4,20	4,65	5,09	5,53	6,05	6,59	7,13	7,85	8,38	9,08	9,78	10,47	11,33	12,18
600	4,79	5,33	5,86	6,50	7,13	7,76	8,49	9,26	10,03	11,04	11,79	12,78	13,75	14,72	15,90	17,07
700	5,40	6,02	6,63	7,36	8,08	8,80	9,63	10,51	11,38	12,52	13,37	14,48	15,58	16,66	17,98	19,28
750	5,70	6,35	7,00	7,78	8,54	9,30	10,18	11,11	12,02	13,23	14,12	15,29	16,45	17,58	18,97	20,32
900	6,54	7,31	8,06	8,96	9,85	10,73	11,74	12,81	13,87	15,24	16,26	17,59	18,89	20,15	21,69	23,18
1.000	7,07	7,90	8,73	9,71	10,67	11,62	12,72	13,87	15,01	16,49	17,57	18,99	20,36	21,70	23,31	24,85
1.400	8,91	9,98	11,04	12,29	13,51	14,70	16,06	17,47	18,83	20,58	21,83	23,42	24,92	26,32	27,93	29,36
1.500	9,29	10,42	11,53	12,83	14,10	15,34	16,74	18,19	19,59	21,36	22,63	24,21	25,69	27,04	28,56	29,88
1.700	9,98	11,20	12,39	13,78	15,13	16,44	17,91	19,41	20,83	22,61	23,84	25,36	26,71	27,90	29,13	30,07
1.800	10,28	11,54	12,77	14,19	15,57	16,90	18,39	19,90	21,31	23,06	24,26	25,70	26,95	28,01	29,03	
2.000	10,78	12,11	13,39	14,87	16,29	17,64	19,13	20,61	21,98	23,60	24,67	25,89	26,85	27,55		
2.500	11,44	12,84	14,17	15,65	17,02	18,26	19,55	20,72	21,68	22,59						

**$P_d$  (kW) referred to  $i$**

RPM / $i$	1,00/1,01	1,02/1,03	1,04/1,06	1,07/1,08	1,09/1,12	1,13/1,16	1,17/1,22	1,23/1,32	1,33/1,50	OVER 1,51
100	0,00	0,01	0,02	0,02	0,03	0,04	0,05	0,05	0,06	0,07
150	0,00	0,01	0,02	0,03	0,05	0,06	0,07	0,08	0,09	0,10
200	0,00	0,02	0,03	0,05	0,06	0,08	0,09	0,11	0,12	0,14
400	0,00	0,03	0,06	0,09	0,12	0,15	0,19	0,22	0,25	0,28
600	0,00	0,05	0,09	0,14	0,19	0,23	0,28	0,33	0,37	0,42
700	0,00	0,05	0,11	0,16	0,22	0,27	0,33	0,38	0,43	0,49
750	0,00	0,06	0,12	0,17	0,23	0,29	0,35	0,41	0,46	0,52
900	0,00	0,07	0,14	0,21	0,28	0,35	0,42	0,49	0,56	0,63
1.000	0,00	0,08	0,15	0,23	0,31	0,39	0,47	0,54	0,62	0,69
1.400	0,00	0,11	0,22	0,33	0,43	0,54	0,65	0,76	0,87	0,97
1.500	0,00	0,12	0,23	0,35	0,46	0,58	0,70	0,82	0,93	1,04
1.700	0,00	0,13	0,26	0,39	0,52	0,66	0,79	0,92	1,05	1,18
1.800	0,00	0,14	0,28	0,42	0,56	0,69	0,84	0,98	1,11	1,25
2.000	0,00	0,15	0,31	0,46	0,62	0,77	0,93	1,09	1,24	1,39
2.500	0,00	0,19	0,39	0,58	0,77	0,96	1,16	1,36	1,55	1,74

Belt speed is greater than 30 m/s then is necessary to use dynamically balanced pulleys. A reduction in belt life can be expected. Suggested a smaller section.

# CLASSICAL WRAPPED BELTS

## OLEOSTATIC GOLD C SECTION

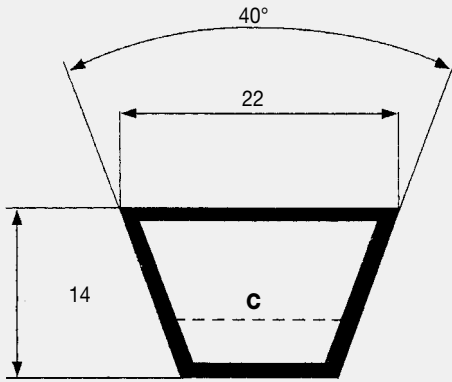

C SECTION	
CODE	INTERNAL LENGTH LI (mm)
C 33 3/4	858
C 37 1/2	950
C 39 3/4	1013
C 43	1090
C 45	1150
C 46	1168
C 48	1220
C 47	1194
C 49	1250
C 51	1295
C 52	1320
C 53	1350
C 54	1372
C 55	1400
C 56	1425
C 57	1450
C 58	1473
C 59	1500
C 60	1524
C 61	1560
C 62	1575
C 62 1/4	1583
C 63	1600
C 65	1650
C 66	1676
C 67	1700
C 68	1727
C 69	1753
C 70	1778
C 71	1798
C 72	1829
C 73	1854
C 74	1879
C 75	1900
C 76	1930
C 77	1955
C 78	1978
C 79	2005
C 80	2032
C 81	2057
C 82	2080
C 83	2108
C 83 1/2	2121
C 84	2134
C 85	2159
C 86	2184
C 87	2208
C 88	2235

C SECTION	
CODE	INTERNAL LENGTH LI (mm)
C 89	2261
C 90	2286
C 92	2337
C 93	2360
C 94	2388
C 95	2413
C 96	2438
C 96 1/2	2450
C 97	2462
C 97 1/2	2477
C 98	2500
C 99	2525
C 100	2540
C 101	2560
C 102	2591
C 104	2642
C 105	2667
C 106	2692
C 108	2750
C 110	2800
C 111	2818
C 112	2845
C 112 1/2	2858
C 114	2888
C 115	2921
C 116	2950
C 117	2965
C 118	3000
C 120	3048
C 122	3099
C 124	3150
C 126	3200
C 128	3250
C 130	3302
C 132	3350
C 134	3404
C 136	3456
C 138	3498
C 140	3550
C 142	3607
C 144	3658
C 147	3733
C 148	3750
C 150	3808
C 153	3902
C 158	4000
C 160	4064
C 161 1/2	4100

C SECTION	
CODE	INTERNAL LENGTH LI (mm)
C 162	4115
C 165	4193
C 166	4216
C 167	4242
C 168	4267
C 170	4318
C 173	4394
C 175	4445
C 177	4500
C 187	4750
C 190	4826
C 195	4953
C 197	5000
C 204	5182
C 208	5300
C 210	5334
C 216	5486
C 220	5550
C 222	5600
C 225	5678
C 228	5753
C 236	6000
C 238	6045
C 240	6062
C 248	6263
C 250	6300
C 255	6438
C 264	6670
C 265	6700
C 270	6822
C 276	6973
C 280	7100
C 285	7203
C 295	7493
C 297	7500
C 300	7582
C 303	7650
C 314	7976
C 315	7965
C 316	8000
C 320	8093
C 330	8382
C 336	8500
C 345	8723
C 360	9107
C 394	10000
C 420	10632
C 424	10733

# CLASSICAL WRAPPED BELTS

## OLEOSTATIC GOLD C SECTION

**TABLE 4 -  $P_b$  (kW) referred to  $\emptyset$  (mm)**

RPM / $\emptyset$	180	190	200	212	224	236	250	265	280	300	315	335	355	375	400	425	450
100	1,14	1,26	1,38	1,52	1,66	1,80	1,96	2,14	2,31	2,54	2,71	2,93	3,16	3,38	3,66	3,93	4,21
200	2,04	2,26	2,48	2,75	3,01	3,27	3,58	3,90	4,22	4,65	4,97	5,39	5,81	6,23	6,75	7,26	7,77
300	2,83	3,15	3,48	3,86	4,24	4,62	5,05	5,52	5,98	6,60	7,05	7,66	8,26	8,86	9,60	10,33	11,06
400	3,56	3,98	4,40	4,89	5,38	5,87	6,43	7,03	7,63	8,42	9,01	9,78	10,55	11,32	12,26	13,20	14,12
500	4,25	4,75	5,26	5,86	6,46	7,05	7,73	8,46	9,19	10,14	10,85	11,79	12,71	13,63	14,76	15,88	16,97
600	4,88	5,48	6,07	6,77	7,47	8,16	8,97	9,82	10,66	11,77	12,59	13,67	14,74	15,80	17,10	18,37	19,62
700	5,48	6,16	6,83	7,64	8,43	9,22	10,13	11,10	12,05	13,30	14,23	15,45	16,64	17,82	19,27	20,68	22,05
800	6,04	6,80	7,56	8,45	9,34	10,22	11,23	12,30	13,36	14,74	15,77	17,10	18,41	19,70	21,26	22,78	24,25
900	6,57	7,41	8,24	9,23	10,20	11,16	12,27	13,44	14,59	16,09	17,20	18,64	20,05	21,42	23,08	24,68	26,21
1000	7,06	7,98	8,88	9,95	11,01	12,05	13,24	14,50	15,74	17,35	18,52	20,05	21,54	22,97	24,70	26,34	27,91
1200	7,95	9,00	10,04	11,26	12,47	13,65	14,99	16,40	17,78	19,55	20,83	22,48	24,06	25,55	27,31	28,94	30,44
1400	8,71	9,88	11,03	12,39	13,71	15,00	16,47	17,99	19,45	21,32	22,65	24,33	25,90	27,35	29,00	30,45	31,68
1600	9,33	10,61	11,85	13,31	14,73	16,10	17,64	19,22	20,73	22,61	23,92	25,54	27,00	28,28	29,65		
1800	9,81	11,17	12,49	14,03	15,51	16,92	18,50	20,09	21,57	23,38	24,60	26,04	27,26				
2000	10,14	11,57	12,94	14,52	16,02	17,45	19,01	20,55	21,94	23,58	24,63						
2400	10,33	11,80	13,20	14,77	16,21	17,52	18,88	20,12									
2800	9,81	11,24	12,54	13,93	15,13	16,13											

**$P_d$  (kW) referred to  $i$**

RPM / $i$	1,00 / 1,01	1,02 / 1,03	1,04 / 1,06	1,07 / 1,08	1,09 / 1,12	1,13 / 1,16	1,17 / 1,22	1,23 / 1,32	1,33 / 1,50	OVER 1,51
100	0,00	0,01	0,02	0,03	0,04	0,05	0,06	0,07	0,08	0,09
200	0,00	0,02	0,04	0,06	0,08	0,10	0,11	0,13	0,15	0,17
300	0,00	0,03	0,06	0,09	0,11	0,14	0,17	0,20	0,23	0,26
400	0,00	0,04	0,08	0,11	0,15	0,19	0,23	0,27	0,31	0,34
500	0,00	0,05	0,10	0,14	0,19	0,24	0,29	0,34	0,38	0,43
600	0,00	0,06	0,11	0,17	0,23	0,29	0,34	0,40	0,46	0,51
700	0,00	0,07	0,13	0,20	0,27	0,33	0,40	0,47	0,53	0,60
800	0,00	0,08	0,15	0,23	0,30	0,38	0,46	0,54	0,61	0,69
900	0,00	0,09	0,17	0,26	0,34	0,43	0,52	0,60	0,69	0,77
1000	0,00	0,09	0,19	0,29	0,38	0,48	0,57	0,67	0,76	0,86
1200	0,00	0,11	0,23	0,34	0,46	0,57	0,69	0,80	0,92	1,03
1400	0,00	0,13	0,27	0,40	0,53	0,67	0,80	0,94	1,07	1,20
1600	0,00	0,15	0,30	0,46	0,61	0,76	0,92	1,07	1,22	1,37
1800	0,00	0,17	0,34	0,52	0,68	0,86	1,03	1,21	1,37	1,54
2000	0,00	0,19	0,38	0,57	0,76	0,95	1,15	1,34	1,53	1,71
2400	0,00	0,23	0,46	0,69	0,91	1,14	1,38	1,61	1,83	2,06
2800	0,00	0,27	0,53	0,80	1,07	1,33	1,61	1,88	2,14	2,40

\* Belt speed is greater than 30 m/s then is necessary to use dynamically balanced pulleys. A reduction in belt life can be expected. Suggested a smaller section.

# CLASSICAL WRAPPED BELTS

## OLEOSTATIC GOLD D SECTION

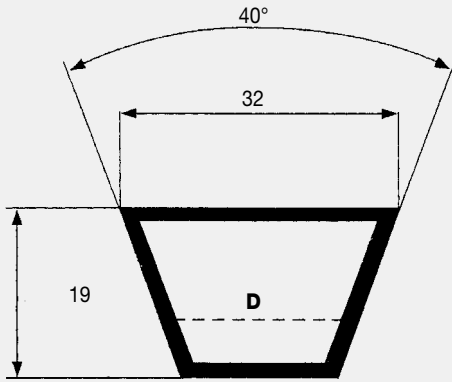

D SECTION	
CODE	INTERNAL LENGTH LI (mm)
D 79	2010
D 98	2500
D 104	2650
D 110	2800
D 118	3000
D 120	3048
D 124	3150
D 128	3251
D 132	3435
D 134	3403
D 135	3429
D 136	3454
D 137	3475
D 140	3550
D 144	3658
D 148	3760
D 154	3914
D 158	4013
D 162	4115
D 167	4241
D 170	4310
D 173	4394
D 175	4445

D SECTION	
CODE	INTERNAL LENGTH LI (mm)
D 177	4500
D 180	4572
D 187	4750
D 195	4953
D 197	5000
D 204	5182
D 205	5209
D 207	5259
D 208	5283
D 210	5334
D 220	5588
D 223	5600
D 225	5659
D 236	5940
D 238	6000
D 240	6039
D 248	6244
D 250	6294
D 255	6424
D 264	6650
D 266	6700
D 270	6804
D 280	7050

D SECTION	
CODE	INTERNAL LENGTH LI (mm)
D 282	7100
D 285	7184
D 295	7425
D 298	7500
D 300	7565
D 314	7924
D 315	7950
D 316	7974
D 326	8224
D 330	8329
D 345	8709
D 354	8940
D 360	9090
D 374	9445
D 390	9849
D 394	10000
D 420	10624
D 441	11200
D 480	12139
D 510	12897
D 540	13659
D 600	15184

# CLASSICAL WRAPPED BELTS

## OLEOSTATIC GOLD D SECTION

**TABLE 4 -  $P_b$  (kW) referred to  $\emptyset$  (mm)**

RPM / $\emptyset$	300	315	355	400	450	500	560	630	710	800	900
50	1,76	1,90	2,26	2,66	3,10	3,53	4,05	4,65	5,32	6,07	6,90
100	3,22	3,47	4,15	4,90	5,72	6,54	7,51	8,63	9,89	11,30	12,83
150	4,55	4,92	5,89	6,98	8,17	9,34	10,74	12,34	14,15	16,15	18,34
200	5,80	6,28	7,54	8,94	10,48	12,00	13,80	15,86	18,17	20,73	23,51
300	8,13	8,82	10,62	12,63	14,81	16,96	19,50	22,39	25,61	29,12	32,88
400	10,27	11,15	13,47	16,03	18,81	21,52	24,70	28,29	32,23	36,46	40,89
500	12,26	13,32	16,11	19,17	22,48	25,68	29,40	33,54	38,00	42,66	47,35
600	14,10	15,33	18,55	22,06	25,82	29,44	33,56	38,08	42,81	47,56	52,04
750	16,60	18,05	21,83	25,91	30,20	34,24	38,72	43,41	48,00	52,09	
900	18,77	20,41	24,65	29,13	33,74	37,95	42,40	46,71	50,37		
1000	20,03	21,78	26,24	30,90	35,59	39,74	43,93	47,64			
1200	22,07	23,97	28,70	33,45	37,93	41,51					
1400	23,43	25,38	30,10	34,52	38,23						
1500	23,83	25,77	30,36	34,45							
1700	24,04	25,86	30,56								
1800	24,44	25,98	30,69								
1900	24,89	26,12									
2000	25,15	26,33									

**$P_d$  (kW) referred to  $i$**

RPM / $i$	1,00 / 1,01	1,02 / 1,03	1,04 / 1,06	1,07 / 1,08	1,09 / 1,12	1,13 / 1,16	1,17 / 1,22	1,23 / 1,32	1,33 / 1,50	OVER 1,51
50	0,00	0,01	0,03	0,04	0,06	0,07	0,09	0,10	0,11	0,13
100	0,00	0,03	0,06	0,09	0,11	0,14	0,17	0,20	0,23	0,26
150	0,00	0,04	0,09	0,13	0,17	0,21	0,26	0,30	0,34	0,39
200	0,00	0,06	0,11	0,17	0,23	0,28	0,34	0,40	0,46	0,51
300	0,00	0,09	0,17	0,26	0,34	0,43	0,52	0,60	0,69	0,77
400	0,00	0,11	0,23	0,34	0,46	0,57	0,69	0,80	0,91	1,03
500	0,00	0,14	0,29	0,43	0,57	0,71	0,86	1,00	1,14	1,28
600	0,00	0,17	0,34	0,52	0,68	0,85	1,03	1,20	1,37	1,54
750	0,00	0,21	0,43	0,64	0,86	1,07	1,29	1,51	1,71	1,93
900	0,00	0,26	0,51	0,77	1,03	1,28	1,55	1,81	2,06	2,31
1000	0,00	0,28	0,57	0,86	1,14	1,42	1,72	2,01	2,29	2,57
1200	0,00	0,34	0,69	1,03	1,37	1,71	2,07	2,41	2,74	3,08
1400	0,00	0,40	0,80	1,20	1,60	1,99	2,41	2,81	3,20	3,60
1500	0,00	0,43	0,86	1,29	1,71	2,14	2,58	3,01	3,43	3,85
1700	0,00	0,48	0,97	1,46	1,94	2,42	2,93	3,41	3,89	4,37
1800	0,00	0,51	1,03	1,55	2,05	2,56	3,10	3,61	4,11	4,62
1900	0,00	0,54	1,09	1,63	2,17	2,71	3,27	3,82	4,34	4,88
2000	0,00	0,57	1,14	1,72	2,28	2,85	3,44	4,02	4,57	5,14

\* Belt speed is greater than 30 m/s then is necessary to use dynamically balanced pulleys. A reduction in belt life can be expected. Suggested a smaller section.

# CLASSICAL WRAPPED BELTS

## OLEOSTATIC GOLD E SECTION

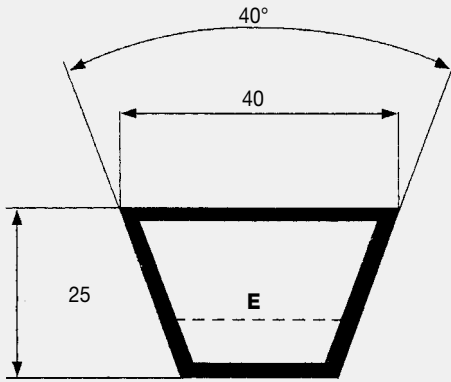

E SECTION	
CODE	INTERNAL LENGTH LI (mm)
E 180	4575
E 197	5000
E 210	5335
E 220	5600
E 226	5660
E 240	6015
E 248	6220
E 255	6400
E 270	6780

E SECTION	
CODE	INTERNAL LENGTH LI (mm)
E 280	7100
E 285	7160
E 295	7500
E 300	7540
E 316	7950
E 330	8305
E 345	8685
E 354	9000
E 360	9065

E SECTION	
CODE	INTERNAL LENGTH LI (mm)
E 394	9930
E 420	10600
E 441	11200
E 480	12115
E 492	12500
E 540	13635
E 600	15160

# CLASSICAL WRAPPED BELTS

## OLEOSTATIC GOLD E SECTION

**TABLE 4 -  $P_b$  (kW) referred to  $\emptyset$  (mm)**

RPM / $\emptyset$	450	500	560	630	710	800	900	1000	1120	1250
50	4,06	4,71	5,49	6,38	7,40	8,52	9,76	10,99	12,44	14,00
100	7,41	8,64	10,09	11,77	13,66	15,77	18,07	20,34	23,04	25,91
150	10,48	12,25	14,34	16,75	19,46	22,46	25,73	28,95	32,74	36,76
200	13,37	15,64	18,49	21,64	25,21	29,17	33,51	37,81	42,91	48,37
250	16,09	18,85	22,11	25,84	30,01	34,58	39,52	44,30	49,82	55,54
300	18,68	21,90	25,69	30,01	34,81	40,05	45,66	51,02	57,14	63,34
400	23,46	27,52	32,26	37,62	43,49	49,76	56,31	62,37	68,97	75,21
500	27,76	32,54	38,06	44,21	50,81	57,67	64,52	70,51	76,44	81,20
600	31,54	36,91	43,03	49,69	56,63	63,52	69,92	74,88	78,76	85,23
700	34,80	40,60	47,09	53,94	60,77	67,04	72,08	74,91	80,22	
750	36,22	42,18	48,75	55,57	62,14	67,83	72,15	75,05		
900	39,57	45,71	52,13	58,23	63,17	67,94				
1000	41,00	46,99	52,92	57,97	63,23					
1100	41,73	47,33	53,05	58,16						
1200	41,69	47,52	53,19							
1300	41,89	47,64	53,27							
1400	42,03	47,79								
1450	42,15	47,90								

**$P_a$  (kW) referred to  $i$**

RPM / $i$	1,00 / 1,01	1,02 / 1,03	1,04 / 1,06	1,07 / 1,08	1,09 / 1,12	1,13 / 1,16	1,17 / 1,22	1,23 / 1,32	1,33 / 1,50	OVER 1,51
50	0,00	0,02	0,05	0,07	0,09	0,12	0,14	0,17	0,19	0,21
100	0,00	0,05	0,09	0,14	0,19	0,24	0,29	0,33	0,38	0,43
150	0,00	0,07	0,14	0,21	0,28	0,35	0,43	0,50	0,57	0,64
200	0,00	0,09	0,19	0,28	0,38	0,47	0,57	0,67	0,76	0,85
250	0,00	0,12	0,24	0,36	0,47	0,59	0,71	0,83	0,95	1,06
300	0,00	0,14	0,28	0,43	0,57	0,71	0,86	1,00	1,14	1,28
400	0,00	0,19	0,38	0,57	0,76	0,94	1,14	1,33	1,51	1,70
500	0,00	0,24	0,47	0,71	0,94	1,18	1,43	1,66	1,89	2,13
600	0,00	0,28	0,57	0,85	1,13	1,42	1,71	2,00	2,27	2,55
700	0,00	0,33	0,66	1,00	1,32	1,65	2,00	2,33	2,65	2,98
750	0,00	0,35	0,71	1,07	1,42	1,77	2,14	2,50	2,84	3,19
900	0,00	0,42	0,85	1,28	1,70	2,12	2,57	2,99	3,41	3,83
1000	0,00	0,47	0,95	1,42	1,89	2,36	2,85	3,33	3,79	4,25
1100	0,00	0,52	1,04	1,56	2,08	2,60	3,14	3,66	4,17	4,68
1200	0,00	0,56	1,14	1,71	2,27	2,83	3,42	3,99	4,54	5,11
1300	0,00	0,61	1,23	1,85	2,46	3,07	3,71	4,32	4,92	5,53
1400	0,00	0,66	1,32	1,99	2,64	3,30	3,99	4,66	5,30	5,96
1450	0,00	0,68	1,37	2,06	2,74	3,42	4,14	4,82	5,49	6,17

\* Belt speed is greater than 30 m/s then is necessary to use dynamically balanced pulleys. A reduction in belt life can be expected. Suggested a smaller section.

# CLASSICAL WRAPPED BELTS

## OLEOSTATIC 20 SECTION

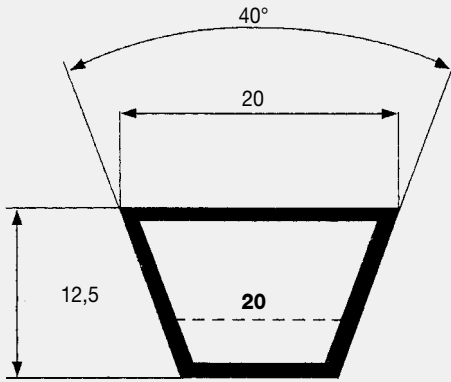

20 SECTION	
CODE	INTERNAL LENGTH LI (mm)
20	1800
20	1875
20	1900
20	1925
20	1950
20	2000
20	2050
20	2120
20	2200
20	2240
20	2360

20 SECTION	
CODE	INTERNAL LENGTH LI (mm)
20	2500
20	2600
20	2650
20	2800
20	3000
20	3150
20	3250
20	3350
20	3450
20	3550
20	3650

20 SECTION	
CODE	INTERNAL LENGTH LI (mm)
20	3750
20	4000
20	4250
20	4500
20	4750
20	5000
20	5300
20	5600
20	6000

# CLASSICAL WRAPPED BELTS

## OLEOSTATIC 20 SECTION

**TABLE 4 -  $P_b$  (kW) referred to  $\emptyset$  (mm)**

RPM / $\emptyset$	140	160	180	200	224	236	250	280	315	355
50	0,34	0,41	0,49	0,56	0,64	0,68	0,73	0,84	0,96	1,09
100	0,60	0,73	0,88	1,01	1,16	1,24	1,34	1,52	1,74	1,99
200	1,05	1,31	1,55	1,79	2,08	2,22	2,39	2,73	3,13	3,58
400	1,79	2,24	2,69	3,13	3,64	3,90	4,19	4,81	5,52	6,30
600	2,40	3,04	3,66	4,27	4,99	5,34	5,74	6,60	7,56	8,61
700	2,67	3,40	4,10	4,79	5,60	5,99	6,45	7,40	8,47	9,63
800	2,92	3,72	4,51	5,27	6,16	6,60	7,10	8,14	9,29	10,55
900	3,15	4,04	4,90	5,73	6,70	7,17	7,71	8,82	10,06	11,38
1000	3,38	4,34	5,25	6,15	7,19	7,70	8,27	9,46	10,75	12,11
1200	3,76	4,86	5,91	6,92	8,08	8,63	9,26	10,54	11,89	13,27
1400	4,09	5,30	6,47	7,56	8,81	9,39	10,06	11,37	12,71	13,97
1600	4,36	5,68	6,93	8,09	9,38	10,00	10,66	11,94	13,17	14,20
1800	4,57	6,04	7,28	8,50	9,80	10,40	11,05	12,23	13,24	13,89
2000	4,73	6,20	7,55	8,77	10,05	10,62	11,20	12,21	12,89	12,99
2300	4,86	6,39	7,74	8,93	10,08	10,54	10,99	11,55		
2600	4,85	6,39	7,69	8,74	9,65	9,95				
2900	4,68	6,18	7,36	8,20	8,74					
3000	4,60	6,07	7,19	7,95	8,31					

**$P_a$  (kW) referred to  $i$**

RPM / $i$	1,00/1,01	1,02/1,03	1,04/1,06	1,07/1,08	1,09/1,12	1,13/1,16	1,17/1,22	1,23/1,32	1,33/1,50	OVER 1,51
50	0,00	0,00	0,01	0,01	0,02	0,02	0,03	0,03	0,04	0,04
100	0,00	0,01	0,02	0,03	0,04	0,05	0,05	0,06	0,07	0,07
200	0,00	0,02	0,04	0,05	0,07	0,09	0,10	0,12	0,14	0,15
400	0,00	0,04	0,07	0,10	0,14	0,17	0,21	0,23	0,27	0,31
600	0,00	0,05	0,10	0,15	0,21	0,26	0,31	0,36	0,41	0,46
700	0,00	0,06	0,12	0,18	0,24	0,30	0,36	0,41	0,48	0,53
800	0,00	0,07	0,14	0,21	0,27	0,34	0,41	0,48	0,54	0,61
900	0,00	0,08	0,15	0,23	0,31	0,39	0,46	0,54	0,61	0,68
1000	0,00	0,08	0,17	0,26	0,34	0,43	0,51	0,59	0,68	0,77
1200	0,00	0,10	0,21	0,31	0,41	0,52	0,61	0,72	0,82	0,92
1400	0,00	0,12	0,24	0,36	0,48	0,60	0,71	0,84	0,95	1,07
1600	0,00	0,14	0,27	0,41	0,55	0,68	0,81	0,95	1,08	1,22
1800	0,00	0,15	0,31	0,47	0,61	0,77	0,92	1,07	1,22	1,38
2000	0,00	0,17	0,34	0,51	0,68	0,86	1,02	1,19	1,36	1,53
2300	0,00	0,20	0,39	0,59	0,79	0,98	1,17	1,37	1,56	1,76
2600	0,00	0,22	0,44	0,67	0,89	1,11	1,32	1,55	1,77	1,99
2900	0,00	0,24	0,50	0,75	0,99	1,24	1,48	1,73	1,97	2,21
3000	0,00	0,25	0,51	0,77	1,03	1,29	1,53	1,79	2,04	2,30

\* Belt speed is greater than 30 m/s then is necessary to use dynamically balanced pulleys. A reduction in belt life can be expected. Suggested a smaller section.

# CLASSICAL WRAPPED BELTS

## OLEOSTATIC 25 SECTION

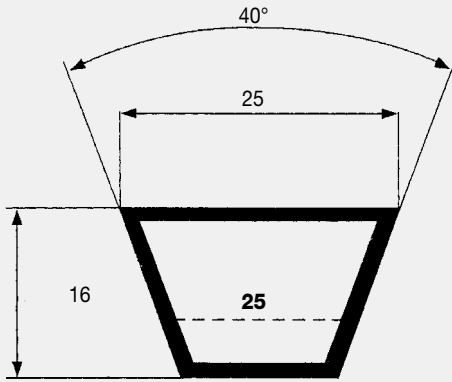

25 SECTION	
CODE	INTERNAL LENGTH LI (mm)
25	1800
25	1900
25	1950
25	2000
25	2050
25	2120
25	2200
25	2240
25	2325
25	2360
25	2450
25	2500
25	2650
25	2700
25	2800

25 SECTION	
CODE	INTERNAL LENGTH LI (mm)
25	2950
25	3000
25	3150
25	3300
25	3350
25	3550
25	3750
25	3950
25	4000
25	4250
25	4450
25	4500
25	4750
25	5000
25	5300

25 SECTION	
CODE	INTERNAL LENGTH LI (mm)
25	5600
25	5700
25	6000
25	6300
25	6500
25	6700
25	7100
25	7500
25	8000
25	8500
25	9000
25	9500
25	10000

# CLASSICAL WRAPPED BELTS

## OLEOSTATIC 25 SECTION

**TABLE 4 -  $P_b$  (kW) referred to  $\emptyset$  (mm)**

RPM / $\emptyset$	224	236	250	280	315	335	400	450	500	560
50	0,71	0,8	0,88	1,06	1,28	1,52	1,8	2,09	2,39	2,74
100	1,29	1,43	1,59	1,94	2,35	2,81	3,32	3,88	4,44	5,09
200	2,25	2,53	2,94	3,5	4,25	5,12	6,07	7,12	8,15	9,37
400	3,88	4,38	4,96	6,17	7,58	9,15	10,89	12,78	14,62	16,77
600	5,21	5,92	6,73	8,46	10,41	12,6	14,98	17,52	19,96	22,74
800	6,22	7,2	8,34	10,38	12,81	15,48	18,33	21,3	24,04	27,02
900	6,78	7,75	8,87	11,22	13,84	16,69	19,7	22,77	25,54	28,43
1000	7,19	8,24	9,45	11,95	14,75	17,74	20,84	23,94	26,63	29,29
1200	7,84	9,13	10,37	12,13	16,17	19,31	22,41	25,29	27,5	29,18
1400	8,25	9,54	10,99	13,92	17,02	20,09	22,91	25,13		
1500	8,36	9,68	11,17	14,15	17,22	20,18	22,71	24,44		
1600	8,4	9,75	11,26	14,24	17,25	20,01				
1700	8,37	9,74	11,26	14,22	17,11	19,61				
1800	8,27	9,65	11,16	14,06	16,78					
2000	7,85	9,21	10,67	13,32	15,56					
2200	7,11	8,39	9,73	12						
2400	6,02	7,18	8,33							
2500	5,33	6,42	7,45							

**$P_a$  (kW) referred to  $i$**

RPM / $i$	1,00/1,01	1,02/1,03	1,04/1,06	1,07/1,08	1,09/1,12	1,13/1,16	1,17/1,22	1,23/1,32	1,33/1,50	OVER 1,51
50	0,00	0,01	0,01	0,02	0,02	0,03	0,03	0,04	0,04	0,04
100	0,00	0,01	0,02	0,03	0,04	0,06	0,07	0,08	0,09	0,09
200	0,00	0,02	0,04	0,07	0,09	0,11	0,12	0,14	0,17	0,19
400	0,00	0,04	0,09	0,12	0,17	0,21	0,25	0,29	0,33	0,37
600	0,00	0,07	0,12	0,19	0,25	0,32	0,37	0,44	0,50	0,56
800	0,00	0,08	0,14	0,22	0,30	0,36	0,44	0,51	0,58	0,65
900	0,00	0,09	0,17	0,25	0,33	0,42	0,50	0,58	0,66	0,75
1000	0,00	0,10	0,19	0,29	0,37	0,47	0,56	0,66	0,75	0,84
1200	0,00	0,10	0,21	0,32	0,42	0,53	0,63	0,73	0,84	0,94
1400	0,00	0,14	0,30	0,44	0,58	0,74	0,87	1,02	1,17	1,31
1500	0,00	0,15	0,32	0,47	0,63	0,78	0,94	1,09	1,24	1,40
1600	0,00	0,17	0,33	0,51	0,67	0,84	0,99	1,17	1,32	1,49
1700	0,00	0,18	0,35	0,54	0,72	0,89	1,06	1,24	1,41	1,58
1800	0,00	0,19	0,37	0,57	0,75	0,95	1,12	1,31	1,50	1,68
2000	0,00	0,21	0,42	0,63	0,84	1,05	1,24	1,45	1,66	1,87
2200	0,00	0,23	0,46	0,69	0,92	1,15	1,37	1,60	1,83	2,05
2400	0,00	0,25	0,51	0,76	1,00	1,26	1,50	1,75	2,00	2,24
2500	0,00	0,26	0,53	0,79	1,05	1,31	1,56	1,83	2,08	2,33

\* Belt speed is greater than 30 m/s then is necessary to use dynamically balanced pulleys. A reduction in belt life can be expected. Suggested a smaller section.

# CLASSICAL WRAPPED BELTS

## OLEOSTATIC 45 SECTION

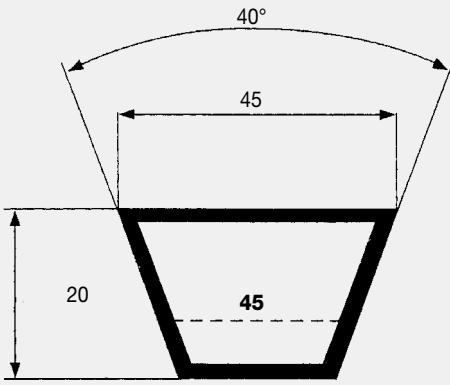

45 SECTION	
CODE	INTERNAL LENGTH LI (mm)
45	2000
45	2300
45	2500
45	2650
45	2750

45 SECTION	
CODE	INTERNAL LENGTH LI (mm)
45	2850
45	3000
45	3150
45	3250
45	3300

45 SECTION	
CODE	INTERNAL LENGTH LI (mm)
45	3500
45	3750
45	4000

## OLEOSTATIC 50 SECTION

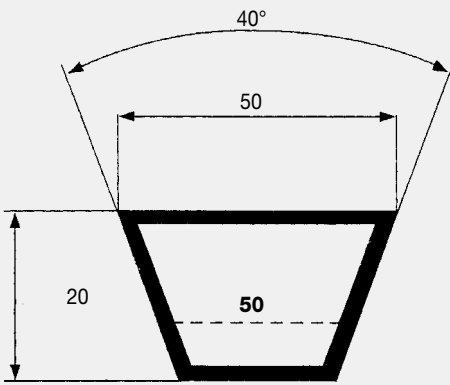

50 SECTION	
CODE	INTERNAL LENGTH LI (mm)
50	2000
50	2050
50	2150
50	2300
50	2500
50	2650

50 SECTION	
CODE	INTERNAL LENGTH LI (mm)
50	2750
50	2850
50	2870
50	3000
50	3150
50	3250

50 SECTION	
CODE	INTERNAL LENGTH LI (mm)
50	4000
50	3500
50	3670
50	3750
50	3950
50	4000





MEGADYNE V-BELTS

# NARROW WRAPPED V-BELTS DIN

EXTRA  
OLEOSTATIC GOLD

# NARROW WRAPPED

## V-BELTS DIN EXTRA - OLEOSTATIC GOLD

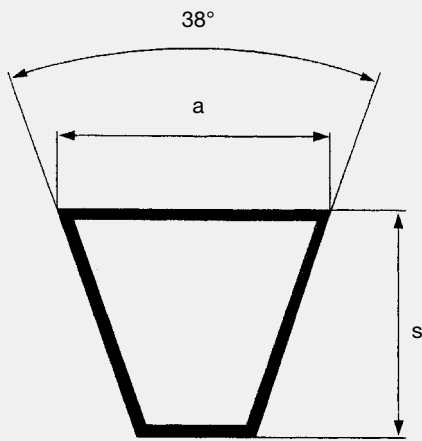

### BELT CHARACTERISTICS

SECTION	SPZ	SPA	SPB	SPC
a (mm)	9,7	12,7	16,3	22
s (mm)	8	10	13	18
Pitch length - internal length = $\Delta i$ (mm)	39	47	61	86
External length - pitch length = $\Delta e$ (mm)	13	18	22	30
Weigth (gr/m)	70	120	195	365
Min. Pulley diam. (Mm)	56	90	140	224
Working temperature	-30°C / +80°C			
Relevant standards	DIN 7753 - ISO 4184			
Relevant antistatic standard	ISO 1813			
Materials	SBR and/or CR blend - polyester cord - cotton/polyester fabric			

TABLE 3 - CORRECTION FACTOR  $C_L$  (according to type and length of the belt)

	512	630	710	732	800	900	1000	1120	1250	1400	1600	1800	2000	2240	2500	2800	3150	3550	4000	4500	5000	5600	6300	7100	8000	9000	10000	11200	12500	
SPZ	0,81	0,82	0,84	0,85	0,86	0,88	0,90	0,93	0,94	0,96	1,00	1,01	1,02	1,05	1,07	1,09	1,11	1,13												
SPA				0,80	0,81	0,83	0,85	0,87	0,89	0,91	0,93	0,95	0,96	0,98	1,00	1,02	1,04	1,06	1,08	1,09										
SPB									0,82	0,84	0,86	0,88	0,90	0,92	0,94	0,96	0,98	1,00	1,02	1,04	1,06	1,08	1,10	1,12	1,14					
SPC													0,81	0,83	0,86	0,88	0,90	0,92	0,94	0,96	0,98	1,00	1,02	1,04	1,06	1,08	1,10	1,12	1,14	

TABLE 5 - INSTALLATION AND TAKE UP ALLOWANCE

L (mm)	Y (mm)				X (mm)
	SPZ	SPA	SPB	SPC	
512 / 670	15	15			10
670 / 1000	15	20			14
1000 / 1250	20	20			18
1250 / 1800	20	25	30		23
1800 / 2240	25	25	30	40	28
2240 / 3000	25	30	35	45	36
3000 / 3500	30	30	40	45	44

# NARROW WRAPPED

## V-BELTS DIN | EXTRA

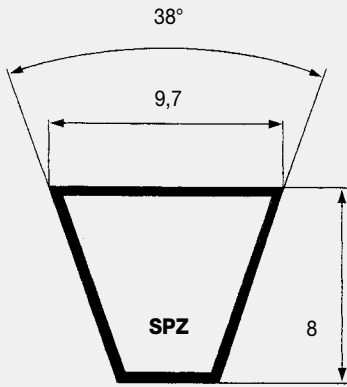

SPZ SECTION	
CODE	EXTERNAL LENGTH LE (mm)
SPZ 487	500
SPZ 512	525
SPZ 562	575
SPZ 587	600
SPZ 607	620
SPZ 612	625
SPZ 630	643
SPZ 637	650
SPZ 662	675
SPZ 670	683
SPZ 687	700
SPZ 710	723
SPZ 722	735
SPZ 737	750
SPZ 750	763
SPZ 762	775
SPZ 772	785
SPZ 787	800
SPZ 800	813
SPZ 812	825
SPZ 825	838
SPZ 837	850
SPZ 850	863
SPZ 862	875
SPZ 875	888
SPZ 887	900
SPZ 900	913
SPZ 912	925
SPZ 922	935
SPZ 925	938
SPZ 937	950
SPZ 950	963
SPZ 962	975
SPZ 975	988
SPZ 987	1000
SPZ 1000	1013
SPZ 1010	1023
SPZ 1012	1025
SPZ 1024	1037
SPZ 1037	1050
SPZ 1047	1060
SPZ 1060	1073
SPZ 1077	1090
SPZ 1087	1100

SPZ SECTION	
CODE	EXTERNAL LENGTH LE (mm)
SPZ 1112	1125
SPZ 1120	1133
SPZ 1137	1150
SPZ 1140	1153
SPZ 1147	1160
SPZ 1150	1163
SPZ 1162	1175
SPZ 1180	1193
SPZ 1187	1200
SPZ 1200	1213
SPZ 1202	1215
SPZ 1212	1225
SPZ 1237	1250
SPZ 1250	1263
SPZ 1262	1275
SPZ 1270	1283
SPZ 1287	1300
SPZ 1312	1325
SPZ 1320	1333
SPZ 1337	1350
SPZ 1340	1353
SPZ 1347	1360
SPZ 1362	1375
SPZ 1387	1400
SPZ 1400	1413
SPZ 1412	1425
SPZ 1420	1433
SPZ 1437	1450
SPZ 1462	1475
SPZ 1470	1483
SPZ 1487	1500
SPZ 1500	1513
SPZ 1512	1525
SPZ 1520	1533
SPZ 1537	1550
SPZ 1562	1575
SPZ 1587	1600
SPZ 1600	1613
SPZ 1612	1625
SPZ 1637	1650
SPZ 1650	1663
SPZ 1662	1675
SPZ 1687	1700
SPZ 1700	1713

SPZ SECTION	
CODE	EXTERNAL LENGTH LE (mm)
SPZ 1737	1750
SPZ 1750	1763
SPZ 1762	1775
SPZ 1787	1800
SPZ 1800	1813
SPZ 1812	1825
SPZ 1837	1850
SPZ 1850	1863
SPZ 1862	1875
SPZ 1887	1900
SPZ 1900	1913
SPZ 1937	1950
SPZ 1962	1975
SPZ 1987	2000
SPZ 2000	2013
SPZ 2019	2032
SPZ 2030	2043
SPZ 2037	2050
SPZ 2062	2075
SPZ 2087	2100
SPZ 2120	2133
SPZ 2137	2150
SPZ 2150	2163
SPZ 2160	2173
SPZ 2187	2200
SPZ 2240	2253
SPZ 2262	2275
SPZ 2287	2300
SPZ 2360	2373
SPZ 2410	2423
SPZ 2437	2450
SPZ 2487	2500
SPZ 2500	2513
SPZ 2540	2553
SPZ 2650	2663
SPZ 2690	2703
SPZ 2800	2813
SPZ 2840	2853
SPZ 3000	3013
SPZ 3150	3163
SPZ 3350	3363
SPZ 3550	3563

# NARROW WRAPPED

## V-BELTS DIN | EXTRA

**TABLE 4 - P<sub>b</sub> (kW) referred to Ø (mm)**

RPM / Ø	56	60	63	67	71	75	80	85	90	95	100	106	112	118	125	132	140
100	0,11	0,12	0,13	0,14	0,14	0,16	0,18	0,20	0,21	0,23	0,25	0,28	0,30	0,32	0,35	0,37	0,40
200	0,19	0,21	0,23	0,26	0,26	0,29	0,33	0,36	0,40	0,44	0,47	0,52	0,56	0,60	0,65	0,70	0,76
500	0,37	0,44	0,48	0,55	0,58	0,65	0,73	0,82	0,91	0,99	1,08	1,18	1,28	1,38	1,50	1,62	1,75
700	0,47	0,56	0,63	0,72	0,77	0,86	0,98	1,10	1,22	1,33	1,45	1,59	1,73	1,87	2,03	2,19	2,37
900	0,56	0,67	0,76	0,87	0,95	1,07	1,22	1,37	1,52	1,66	1,81	1,99	2,16	2,33	2,54	2,74	2,96
1.000	0,61	0,73	0,83	0,95	1,04	1,17	1,34	1,50	1,66	1,82	1,99	2,18	2,37	2,56	2,78	3,00	3,25
1.400	0,75	0,92	1,05	1,21	1,37	1,55	1,78	2,00	2,22	2,44	2,66	2,92	3,18	3,44	3,73	4,03	4,37
1.500	0,79	0,97	1,10	1,28	1,45	1,64	1,88	2,12	2,35	2,59	2,82	3,10	3,37	3,65	3,96	4,28	4,63
1.700	0,85	1,05	1,20	1,40	1,61	1,82	2,09	2,35	2,62	2,88	3,14	3,45	3,75	4,06	4,41	4,76	5,15
1.800	0,88	1,09	1,24	1,45	1,68	1,91	2,19	2,47	2,74	3,02	3,29	3,62	3,94	4,26	4,63	4,99	5,41
2.500	1,07	1,34	1,55	1,83	2,18	2,48	2,85	3,22	3,59	3,95	4,31	4,73	5,16	5,57	6,05	6,52	7,04
2.900	1,14	1,46	1,71	2,01	2,43	2,77	3,20	3,61	4,03	4,44	4,84	5,31	5,78	6,24	6,77	7,29	7,86
3.000	1,17	1,50	1,74	2,06	2,49	2,84	3,28	3,71	4,13	4,55	4,96	5,45	5,93	6,40	6,94	7,47	8,06
3.400	1,24	1,61	1,87	2,23	2,72	3,11	3,59	4,07	4,53	4,99	5,44	5,98	6,50	7,00	7,58	8,14	8,76
3.600	1,27	1,65	1,94	2,32	2,83	3,24	3,74	4,24	4,72	5,20	5,67	6,22	6,76	7,28	7,87	8,45	9,08
4.000	1,33	1,75	2,06	2,48	3,04	3,48	4,02	4,55	5,07	5,58	6,08	6,67	7,23	7,78	8,40	8,99	9,62
5.000	1,44	1,95	2,32	2,83	3,46	3,97	4,60	5,20	5,79	6,36	6,91	7,54	8,14	8,70	9,32	9,89	10,47

**P<sub>a</sub> (kW) referred to i**

RPM / i	1,00/1,01	1,02/1,05	1,06/1,11	1,12/1,18	1,19/1,26	1,27/1,38	1,39/1,57	1,58/1,94	1,95/3,38	OVER 3,39
100	0,00	0,00	0,00	0,01	0,01	0,01	0,01	0,01	0,01	0,01
200	0,00	0,00	0,01	0,01	0,01	0,02	0,02	0,02	0,02	0,03
500	0,00	0,01	0,01	0,03	0,04	0,04	0,05	0,06	0,06	0,07
700	0,00	0,01	0,02	0,04	0,05	0,06	0,07	0,08	0,09	0,09
900	0,00	0,01	0,03	0,05	0,06	0,08	0,09	0,10	0,11	0,12
1.000	0,00	0,01	0,03	0,05	0,07	0,09	0,10	0,11	0,12	0,13
1.400	0,00	0,02	0,04	0,07	0,10	0,12	0,14	0,16	0,17	0,18
1.500	0,00	0,02	0,04	0,08	0,11	0,13	0,15	0,17	0,18	0,20
1.700	0,00	0,02	0,05	0,09	0,12	0,15	0,17	0,19	0,21	0,22
1.800	0,00	0,02	0,05	0,09	0,13	0,15	0,18	0,20	0,22	0,23
2.500	0,00	0,03	0,07	0,13	0,18	0,21	0,25	0,28	0,31	0,33
2.900	0,00	0,03	0,09	0,15	0,21	0,25	0,29	0,33	0,36	0,38
3.000	0,00	0,03	0,09	0,16	0,21	0,26	0,30	0,34	0,37	0,39
3.400	0,00	0,04	0,10	0,18	0,24	0,29	0,34	0,38	0,42	0,44
3.600	0,00	0,04	0,11	0,19	0,25	0,31	0,36	0,41	0,44	0,47
4.000	0,00	0,04	0,12	0,21	0,28	0,34	0,40	0,45	0,49	0,52
5.000	0,00	0,05	0,15	0,26	0,35	0,43	0,50	0,56	0,62	0,65

Belt speed is greater than 30 m/s then is necessary to use dynamically balanced pulleys. A reduction in belt life can be expected. Suggested a smaller section.

# NARROW WRAPPED

## V-BELTS DIN | OLEOSTATIC GOLD

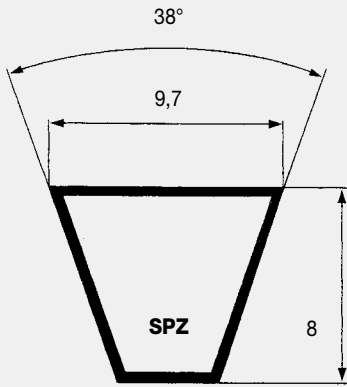

SPZ SECTION	
CODE	EXTERNAL LENGTH LE (mm)
SPZ 487	500
SPZ 512	525
SPZ 562	575
SPZ 587	600
SPZ 607	620
SPZ 612	625
SPZ 630	643
SPZ 637	650
SPZ 662	675
SPZ 670	683
SPZ 687	700
SPZ 710	723
SPZ 722	735
SPZ 737	750
SPZ 750	763
SPZ 762	775
SPZ 772	785
SPZ 787	800
SPZ 800	813
SPZ 812	825
SPZ 825	838
SPZ 837	850
SPZ 850	863
SPZ 862	875
SPZ 875	888
SPZ 887	900
SPZ 900	913
SPZ 912	925
SPZ 922	935
SPZ 925	938
SPZ 937	950
SPZ 950	963
SPZ 962	975
SPZ 975	988
SPZ 987	1000
SPZ 1000	1013
SPZ 1010	1023
SPZ 1012	1025
SPZ 1024	1037
SPZ 1037	1050
SPZ 1047	1060
SPZ 1060	1073
SPZ 1077	1090
SPZ 1087	1100

SPZ SECTION	
CODE	EXTERNAL LENGTH LE (mm)
SPZ 1112	1125
SPZ 1120	1133
SPZ 1137	1150
SPZ 1140	1153
SPZ 1147	1160
SPZ 1150	1163
SPZ 1162	1175
SPZ 1180	1193
SPZ 1187	1200
SPZ 1200	1213
SPZ 1202	1215
SPZ 1212	1225
SPZ 1237	1250
SPZ 1250	1263
SPZ 1262	1275
SPZ 1270	1283
SPZ 1287	1300
SPZ 1312	1325
SPZ 1320	1333
SPZ 1337	1350
SPZ 1340	1353
SPZ 1347	1360
SPZ 1362	1375
SPZ 1387	1400
SPZ 1400	1413
SPZ 1412	1425
SPZ 1420	1433
SPZ 1437	1450
SPZ 1462	1475
SPZ 1470	1483
SPZ 1487	1500
SPZ 1500	1513
SPZ 1512	1525
SPZ 1520	1533
SPZ 1537	1550
SPZ 1562	1575
SPZ 1587	1600
SPZ 1600	1613
SPZ 1612	1625
SPZ 1637	1650
SPZ 1650	1663
SPZ 1662	1675
SPZ 1687	1700
SPZ 1700	1713

SPZ SECTION	
CODE	EXTERNAL LENGTH LE (mm)
SPZ 1737	1750
SPZ 1750	1763
SPZ 1762	1775
SPZ 1787	1800
SPZ 1800	1813
SPZ 1812	1825
SPZ 1837	1850
SPZ 1850	1863
SPZ 1862	1875
SPZ 1887	1900
SPZ 1900	1913
SPZ 1937	1950
SPZ 1962	1975
SPZ 1987	2000
SPZ 2000	2013
SPZ 2019	2032
SPZ 2030	2043
SPZ 2037	2050
SPZ 2062	2075
SPZ 2087	2100
SPZ 2120	2133
SPZ 2137	2150
SPZ 2150	2163
SPZ 2160	2173
SPZ 2187	2200
SPZ 2240	2253
SPZ 2262	2275
SPZ 2287	2300
SPZ 2360	2373
SPZ 2410	2423
SPZ 2437	2450
SPZ 2487	2500
SPZ 2500	2513
SPZ 2540	2553
SPZ 2650	2663
SPZ 2690	2703
SPZ 2800	2813
SPZ 2840	2853
SPZ 3000	3013
SPZ 3150	3163
SPZ 3350	3363
SPZ 3550	3563

# NARROW WRAPPED

## V-BELTS DIN | OLEOSTATIC GOLD

**TABLE 4 -  $P_b$  (kW) referred to  $\emptyset$  (mm)**

RPM / $\emptyset$	63	71	80	90	100	112	125	140	150	160	170	180
100	0,08	0,10	0,13	0,16	0,18	0,22	0,25	0,30	0,32	0,35	0,38	0,41
200	0,14	0,19	0,24	0,29	0,34	0,41	0,48	0,56	0,61	0,66	0,71	0,77
500	0,30	0,41	0,52	0,65	0,78	0,93	1,09	1,27	1,40	1,52	1,64	1,76
700	0,40	0,54	0,70	0,87	1,04	1,25	1,47	1,72	1,89	2,05	2,21	2,38
900	0,48	0,66	0,86	1,08	1,30	1,55	1,83	2,15	2,35	2,56	2,77	2,97
1.000	0,52	0,72	0,94	1,18	1,42	1,70	2,01	2,35	2,58	2,81	3,03	3,26
1.400	0,68	0,94	1,24	1,57	1,89	2,27	2,68	3,15	3,45	3,75	4,05	4,35
1.500	0,71	1,00	1,31	1,66	2,00	2,41	2,85	3,34	3,66	3,98	4,29	4,60
1.700	0,78	1,10	1,45	1,84	2,23	2,68	3,16	3,71	4,06	4,41	4,76	5,10
1.800	0,81	1,15	1,52	1,93	2,33	2,81	3,31	3,88	4,26	4,62	4,98	5,34
2.500	1,02	1,47	1,96	2,50	3,03	3,65	4,30	5,03	5,50	5,95	6,39	6,82
2.900	1,12	1,63	2,19	2,80	3,39	4,08	4,80	5,60	6,10	6,59	7,05	7,49
3.000	1,15	1,67	2,25	2,87	3,48	4,19	4,92	5,73	6,24	6,73	7,20	7,64
3.400	1,23	1,81	2,45	3,14	3,80	4,57	5,35	6,20	6,73	7,24	7,70	8,14*
3.600	1,27	1,88	2,54	3,26	3,95	4,74	5,55	6,41	6,95	7,45	7,91*	8,33*
4.000	1,34	2,00	2,72	3,49	4,22	5,05	5,89	6,77	7,30*	7,78*		
5.000	1,47	2,24	3,06	3,93	4,73	5,61	6,45*					
6.000	1,51	2,37	3,26	4,17	4,99*							

**$P_a$  (kW) referred to  $i$**

RPM / $i$	1,00/1,01	1,02/1,05	1,06/1,11	1,12/1,18	1,19/1,26	1,27/1,38	1,39/1,57	1,58/1,94	1,95/3,38	OVER 3,39
100	0,00	0,00	0,00	0,01	0,01	0,01	0,01	0,01	0,01	0,01
200	0,00	0,00	0,01	0,01	0,01	0,02	0,02	0,02	0,02	0,03
500	0,00	0,01	0,01	0,03	0,04	0,04	0,05	0,06	0,06	0,07
700	0,00	0,01	0,02	0,04	0,05	0,06	0,07	0,08	0,09	0,09
900	0,00	0,01	0,03	0,05	0,06	0,08	0,09	0,10	0,11	0,12
1.000	0,00	0,01	0,03	0,05	0,07	0,09	0,10	0,11	0,12	0,13
1.400	0,00	0,02	0,04	0,07	0,10	0,12	0,14	0,16	0,17	0,18
1.500	0,00	0,02	0,04	0,08	0,11	0,13	0,15	0,17	0,18	0,20
1.700	0,00	0,02	0,05	0,09	0,12	0,15	0,17	0,19	0,21	0,22
1.800	0,00	0,02	0,05	0,09	0,13	0,15	0,18	0,20	0,22	0,23
2.500	0,00	0,03	0,07	0,13	0,18	0,21	0,25	0,28	0,31	0,33
2.900	0,00	0,03	0,09	0,15	0,21	0,25	0,29	0,33	0,36	0,38
3.000	0,00	0,03	0,09	0,16	0,21	0,26	0,30	0,34	0,37	0,39
3.400	0,00	0,04	0,10	0,18	0,24	0,29	0,34	0,38	0,42	0,44
3.600	0,00	0,04	0,11	0,19	0,25	0,31	0,36	0,41	0,44	0,47
4.000	0,00	0,04	0,12	0,21	0,28	0,34	0,40	0,45	0,49	0,52
5.000	0,00	0,05	0,15	0,26	0,35	0,43	0,50	0,56	0,62	0,65
6.000	0,00	0,07	0,18	0,31	0,42	0,51	0,60	0,68	0,74	0,78

\* Belt speed is greater than 30 m/s then is necessary to use dynamically balanced pulleys. A reduction in belt life can be expected. Suggested a smaller section.

# NARROW WRAPPED

## V-BELTS DIN | EXTRA

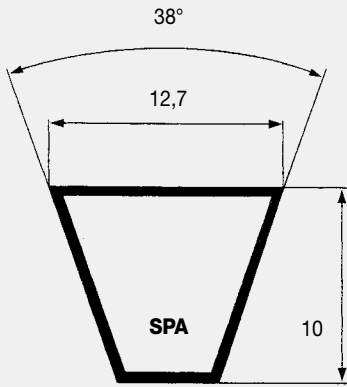

SPA SECTION	
CODE	EXTERNAL LENGTH LE (mm)
SPA 657	675
SPA 707	725
SPA 732	750
SPA 757	775
SPA 782	800
SPA 800	818
SPA 807	825
SPA 832	850
SPA 850	868
SPA 857	875
SPA 882	900
SPA 900	918
SPA 907	925
SPA 925	943
SPA 932	950
SPA 950	968
SPA 957	975
SPA 967	985
SPA 982	1000
SPA 1000	1018
SPA 1007	1025
SPA 1032	1050
SPA 1060	1078
SPA 1082	1100
SPA 1107	1125
SPA 1120	1138
SPA 1132	1150
SPA 1150	1168
SPA 1157	1175
SPA 1180	1198
SPA 1207	1225
SPA 1232	1250
SPA 1250	1268
SPA 1257	1275
SPA 1272	1290
SPA 1282	1300
SPA 1307	1325
SPA 1320	1338
SPA 1332	1350
SPA 1357	1375
SPA 1382	1400
SPA 1400	1418
SPA 1407	1425

SPA SECTION	
CODE	EXTERNAL LENGTH LE (mm)
SPA 1425	1443
SPA 1432	1450
SPA 1450	1468
SPA 1457	1475
SPA 1482	1500
SPA 1500	1518
SPA 1507	1525
SPA 1532	1550
SPA 1550	1568
SPA 1557	1575
SPA 1582	1600
SPA 1600	1618
SPA 1607	1625
SPA 1632	1650
SPA 1657	1675
SPA 1682	1700
SPA 1700	1718
SPA 1707	1725
SPA 1732	1750
SPA 1750	1768
SPA 1757	1775
SPA 1782	1800
SPA 1800	1818
SPA 1807	1825
SPA 1832	1850
SPA 1857	1875
SPA 1882	1900
SPA 1900	1918
SPA 1907	1925
SPA 1925	1943
SPA 1932	1950
SPA 1950	1968
SPA 1957	1975
SPA 1982	2000
SPA 2000	2018
SPA 2032	2050
SPA 2057	2075
SPA 2082	2100
SPA 2120	2138
SPA 2132	2150
SPA 2182	2200
SPA 2207	2225
SPA 2232	2250

SPA SECTION	
CODE	EXTERNAL LENGTH LE (mm)
SPA 2240	2258
SPA 2282	2300
SPA 2300	2318
SPA 2307	2325
SPA 2332	2350
SPA 2360	2378
SPA 2382	2400
SPA 2432	2450
SPA 2482	2500
SPA 2500	2518
SPA 2532	2550
SPA 2582	2600
SPA 2607	2625
SPA 2632	2650
SPA 2650	2668
SPA 2682	2700
SPA 2732	2750
SPA 2782	2800
SPA 2800	2818
SPA 2832	2850
SPA 2847	2865
SPA 2882	2900
SPA 2900	2918
SPA 2932	2950
SPA 2982	3000
SPA 3000	3018
SPA 3032	3050
SPA 3082	3100
SPA 3150	3168
SPA 3182	3200
SPA 3250	3268
SPA 3282	3300
SPA 3350	3368
SPA 3382	3400
SPA 3550	3568
SPA 3650	3668
SPA 3750	3768
SPA 4000	4018
SPA 4250	4268
SPA 4500	4518
SPA 4750	4768

# NARROW WRAPPED

## V-BELTS DIN | EXTRA

**TABLE 4 -  $P_b$  (kW) referred to  $\emptyset$  (mm)**

RPM / $\emptyset$	90	95	100	106	112	118	125	132	140	150	160	170	180	190	200
100	0,30	0,33	0,32	0,36	0,40	0,43	0,48	0,52	0,57	0,63	0,69	0,76	0,82	0,88	0,94
200	0,53	0,59	0,59	0,66	0,74	0,81	0,89	0,97	1,07	1,19	1,30	1,42	1,54	1,65	1,77
500	1,08	1,21	1,31	1,48	1,64	1,81	2,01	2,20	2,43	2,70	2,98	3,25	3,52	3,79	4,06
700	1,39	1,57	1,74	1,97	2,20	2,43	2,70	2,96	3,27	3,64	4,02	4,39	4,76	5,13	5,49
900	1,67	1,89	2,14	2,43	2,73	3,02	3,35	3,69	4,07	4,54	5,01	5,47	5,94	6,40	6,85
1.000	1,80	2,04	2,34	2,66	2,98	3,30	3,67	4,04	4,45	4,97	5,49	6,00	6,51	7,01	7,51
1.400	2,27	2,60	3,07	3,51	3,94	4,37	4,87	5,37	5,93	6,62	7,31	7,99	8,66	9,32	9,98
1.500	2,38	2,72	3,25	3,71	4,17	4,63	5,16	5,68	6,28	7,01	7,74	8,46	9,17	9,87	10,56
1.700	2,58	2,97	3,58	4,10	4,61	5,12	5,71	6,29	6,95	7,77	8,57	9,36	10,14	10,91	11,66
1.800	2,68	3,09	3,74	4,29	4,82	5,36	5,98	6,59	7,28	8,13	8,97	9,80	10,61	11,41	12,19
2.500	3,28	3,82	4,77	5,48	6,18	6,87	7,67	8,46	9,34	10,41	11,46	12,47	13,46	14,41	15,32
2.900	3,58	4,19	5,26	6,06	6,84	7,61	8,50	9,36	10,32	11,49	12,61	13,69	14,72	15,70	16,63
3.000	3,65	4,28	5,38	6,19	7,00	7,78	8,68	9,57	10,54	11,73	12,86	13,95	14,99	15,97	16,89
3.500	3,96	4,68	5,88	6,79	7,67	8,53	9,51	10,46	11,51	12,75	13,92	15,01	16,03	16,96	17,81
3.600	4,02	4,76	5,97	6,89	7,79	8,66	9,66	10,61	11,67	12,91	14,08	15,17	16,17	17,09	17,90
4.000	4,24	5,04	6,28	7,25	8,20	9,11	10,14	11,12	12,19	13,44	14,58	15,61	16,52	17,32	17,98
4.600		5,43	6,59	7,62	8,61	9,55	10,60	11,58	12,61	13,78	14,78	15,62	16,29		
5.000			6,69	7,74	8,74	9,68	10,71	11,65	12,63	13,67	14,53	15,17			

**$P_a$  (kW) referred to  $i$**

RPM / $i$	1,00/1,01	1,02/1,05	1,06/1,11	1,12/1,18	1,19/1,26	1,27/1,38	1,39/1,57	1,58/1,94	1,95/3,38	OVER 3,39
100	0,00	0,00	0,01	0,01	0,02	0,02	0,02	0,03	0,03	0,03
200	0,00	0,01	0,01	0,02	0,03	0,04	0,05	0,05	0,06	0,06
500	0,00	0,01	0,04	0,06	0,08	0,10	0,12	0,13	0,15	0,15
700	0,00	0,02	0,05	0,09	0,12	0,14	0,17	0,19	0,20	0,22
900	0,00	0,02	0,06	0,11	0,15	0,18	0,21	0,24	0,26	0,28
1.000	0,00	0,03	0,07	0,12	0,17	0,20	0,24	0,27	0,29	0,31
1.400	0,00	0,04	0,10	0,17	0,23	0,28	0,33	0,37	0,41	0,43
1.500	0,00	0,04	0,11	0,18	0,25	0,30	0,36	0,40	0,44	0,46
1.700	0,00	0,04	0,12	0,21	0,28	0,34	0,40	0,45	0,49	0,52
1.800	0,00	0,05	0,13	0,22	0,30	0,36	0,43	0,48	0,52	0,55
2.500	0,00	0,06	0,18	0,31	0,42	0,51	0,59	0,67	0,73	0,77
2.900	0,00	0,08	0,20	0,36	0,48	0,59	0,69	0,77	0,84	0,89
3.000	0,00	0,08	0,21	0,37	0,50	0,61	0,71	0,80	0,87	0,92
3.500	0,00	0,09	0,25	0,43	0,59	0,71	0,83	0,93	1,02	1,08
3.600	0,00	0,09	0,25	0,44	0,60	0,73	0,85	0,96	1,05	1,11
4.000	0,00	0,10	0,28	0,49	0,67	0,81	0,95	1,07	1,16	1,23
4.600	0,00	0,12	0,32	0,57	0,77	0,93	1,09	1,23	1,34	1,42
5.000	0,00	0,13	0,35	0,61	0,84	1,01	1,19	1,34	1,45	1,54

Belt speed is greater than 30 m/s then is necessary to use dynamically balanced pulleys. A reduction in belt life can be expected. Suggested a smaller section.

# NARROW WRAPPED

## V-BELTS DIN | OLEOSTATIC GOLD

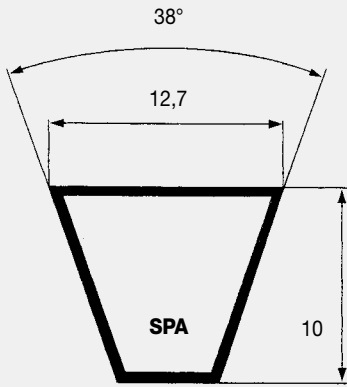

SPA SECTION	
CODE	EXTERNAL LENGTH LE (mm)
SPA 657	675
SPA 707	725
SPA 732	750
SPA 757	775
SPA 782	800
SPA 800	818
SPA 807	825
SPA 832	850
SPA 850	868
SPA 857	875
SPA 882	900
SPA 900	918
SPA 907	925
SPA 925	943
SPA 932	950
SPA 950	968
SPA 957	975
SPA 967	985
SPA 982	1000
SPA 1000	1018
SPA 1007	1025
SPA 1032	1050
SPA 1060	1078
SPA 1082	1100
SPA 1107	1125
SPA 1120	1138
SPA 1132	1150
SPA 1150	1168
SPA 1157	1175
SPA 1180	1198
SPA 1207	1225
SPA 1232	1250
SPA 1250	1268
SPA 1257	1275
SPA 1272	1290
SPA 1282	1300
SPA 1307	1325
SPA 1320	1338
SPA 1332	1350
SPA 1357	1375
SPA 1382	1400
SPA 1400	1418
SPA 1407	1425

SPA SECTION	
CODE	EXTERNAL LENGTH LE (mm)
SPA 1425	1443
SPA 1432	1450
SPA 1450	1468
SPA 1457	1475
SPA 1482	1500
SPA 1500	1518
SPA 1507	1525
SPA 1532	1550
SPA 1550	1568
SPA 1557	1575
SPA 1582	1600
SPA 1600	1618
SPA 1607	1625
SPA 1632	1650
SPA 1657	1675
SPA 1682	1700
SPA 1700	1718
SPA 1707	1725
SPA 1732	1750
SPA 1750	1768
SPA 1757	1775
SPA 1782	1800
SPA 1800	1818
SPA 1807	1825
SPA 1832	1850
SPA 1857	1875
SPA 1882	1900
SPA 1900	1918
SPA 1907	1925
SPA 1925	1943
SPA 1932	1950
SPA 1950	1968
SPA 1957	1975
SPA 1982	2000
SPA 2000	2018
SPA 2032	2050
SPA 2057	2075
SPA 2082	2100
SPA 2120	2138
SPA 2132	2150
SPA 2182	2200
SPA 2207	2225
SPA 2232	2250

SPA SECTION	
CODE	EXTERNAL LENGTH LE (mm)
SPA 2240	2258
SPA 2282	2300
SPA 2300	2318
SPA 2307	2325
SPA 2332	2350
SPA 2360	2378
SPA 2382	2400
SPA 2432	2450
SPA 2482	2500
SPA 2500	2518
SPA 2532	2550
SPA 2582	2600
SPA 2607	2625
SPA 2632	2650
SPA 2650	2668
SPA 2682	2700
SPA 2732	2750
SPA 2782	2800
SPA 2800	2818
SPA 2832	2850
SPA 2847	2865
SPA 2882	2900
SPA 2900	2918
SPA 2932	2950
SPA 2982	3000
SPA 3000	3018
SPA 3032	3050
SPA 3082	3100
SPA 3150	3168
SPA 3182	3200
SPA 3250	3268
SPA 3282	3300
SPA 3350	3368
SPA 3382	3400
SPA 3550	3568
SPA 3650	3668
SPA 3750	3768
SPA 4000	4018
SPA 4250	4268
SPA 4500	4518
SPA 4750	4768

# NARROW WRAPPED

## V-BELTS DIN | OLEOSTATIC GOLD

**TABLE 4 - P<sub>b</sub> (kW) referred to Ø (mm)**

RPM / Ø	90	100	106	112	118	132	150	170	190	212	236	250
100	0,26	0,33	0,37	0,41	0,46	0,55	0,68	0,82	0,95	1,10	1,27	1,36
200	0,47	0,61	0,69	0,77	0,85	1,04	1,28	1,55	1,81	2,10	2,41	2,59
500	1,02	1,34	1,54	1,73	1,92	2,37	2,94	3,56	4,18	4,86	5,59	6,02
700	1,34	1,79	2,05	2,32	2,58	3,19	3,97	4,82	5,66	6,58	7,57	8,14
900	1,65	2,21	2,54	2,88	3,21	3,98	4,95	6,02	7,08	8,22	9,45	10,16
1.000	1,79	2,41	2,78	3,15	3,51	4,36	5,43	6,60	7,76	9,01	10,36	11,13
1.400	2,33	3,17	3,67	4,17	4,66	5,80	7,24	8,80	10,33	11,96	13,69	14,67
1.500	2,45	3,35	3,88	4,41	4,93	6,14	7,66	9,32	10,93	12,65	14,45	15,47
1.700	2,69	3,69	4,28	4,87	5,45	6,80	8,48	10,31	12,07	13,93	15,87	16,96
1.800	2,81	3,86	4,48	5,10	5,71	7,11	8,88	10,78	12,61	14,54	16,53	17,64
2.500	3,50	4,88	5,70	6,50	7,29	9,09	11,31	13,63	15,78	17,95	20,04*	21,12*
2.900	3,82	5,36	6,27	7,16	8,04	10,02	12,41	14,85	17,05	19,15*		
3.000	3,88	5,47	6,40	7,31	8,21	10,22	12,65	15,11	17,30	19,36*		
3.500	4,17	5,93	6,95	7,95	8,92	11,08	13,60	16,04*	18,06*			
3.600	4,21	6,00	7,05	8,06	9,04	11,21	13,74	16,15*				
4.000	4,34	6,24	7,34	8,40	9,42	11,63	14,12*					
4.600	4,39	6,41	7,56	8,65	9,68	11,84*						
5.000	4,32	6,39	7,54	8,62	9,63*	11,69*						

**P<sub>a</sub> (kW) referred to i**

RPM / I	1,00/1,01	1,02/1,05	1,06/1,11	1,12/1,18	1,19/1,26	1,27/1,38	1,39/1,57	1,58/1,94	1,95/3,38	OVER 3,39
100	0,00	0,00	0,01	0,02	0,02	0,03	0,03	0,03	0,04	0,04
200	0,00	0,01	0,02	0,03	0,04	0,05	0,06	0,07	0,07	0,08
500	0,00	0,02	0,05	0,08	0,11	0,13	0,15	0,17	0,19	0,20
700	0,00	0,02	0,06	0,11	0,15	0,18	0,21	0,24	0,26	0,28
900	0,00	0,03	0,08	0,14	0,19	0,23	0,27	0,31	0,34	0,35
1.000	0,00	0,03	0,09	0,16	0,21	0,26	0,30	0,34	0,37	0,39
1.400	0,00	0,05	0,13	0,22	0,30	0,36	0,43	0,48	0,52	0,55
1.500	0,00	0,05	0,14	0,24	0,32	0,39	0,46	0,51	0,56	0,59
1.700	0,00	0,06	0,15	0,27	0,36	0,44	0,52	0,58	0,63	0,67
1.800	0,00	0,06	0,16	0,28	0,39	0,47	0,55	0,62	0,67	0,71
2.500	0,00	0,08	0,23	0,39	0,53	0,65	0,76	0,85	0,93	0,99
2.900	0,00	0,10	0,26	0,46	0,62	0,75	0,88	0,99	1,08	1,14
3.000	0,00	0,10	0,27	0,47	0,64	0,78	0,91	1,03	1,12	1,18
3.500	0,00	0,12	0,32	0,55	0,75	0,91	1,06	1,20	1,30	1,38
3.600	0,00	0,12	0,32	0,57	0,77	0,93	1,09	1,23	1,34	1,42
4.000	0,00	0,13	0,36	0,63	0,86	1,04	1,21	1,37	1,49	1,58
4.600	0,00	0,15	0,41	0,72	0,98	1,19	1,40	1,57	1,71	1,81
5.000	0,00	0,17	0,45	0,79	1,07	1,30	1,52	1,71	1,86	1,97

\* Belt speed is greater than 30 m/s then is necessary to use dynamically balanced pulleys. A reduction in belt life can be expected. Suggested a smaller section.

# NARROW WRAPPED

## V-BELTS DIN | EXTRA

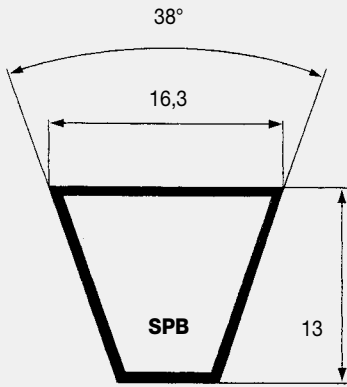

SPB SECTION	
CODE	EXTERNAL LENGTH LE (mm)
SPB 1250	1272
SPB 1320	1342
SPB 1400	1422
SPB 1410	1432
SPB 1450	1472
SPB 1500	1522
SPB 1600	1622
SPB 1650	1672
SPB 1700	1722
SPB 1750	1772
SPB 1800	1822
SPB 1850	1872
SPB 1860	1882
SPB 1900	1922
SPB 1950	1972
SPB 2000	2022
SPB 2020	2042
SPB 2060	2082
SPB 2098	2120
SPB 2120	2142
SPB 2150	2172
SPB 2180	2202
SPB 2240	2262
SPB 2264	2286
SPB 2280	2302

SPB SECTION	
CODE	EXTERNAL LENGTH LE (mm)
SPB 2300	2322
SPB 2360	2382
SPB 2391	2413
SPB 2400	2422
SPB 2410	2432
SPB 2430	2452
SPB 2450	2472
SPB 2500	2522
SPB 2530	2552
SPB 2580	2602
SPB 2600	2622
SPB 2650	2672
SPB 2680	2702
SPB 2720	2742
SPB 2800	2822
SPB 2840	2862
SPB 2850	2872
SPB 2900	2922
SPB 2950	2972
SPB 3000	3022
SPB 3070	3092
SPB 3150	3172
SPB 3170	3192
SPB 3250	3272
SPB 3320	3342

SPB SECTION	
CODE	EXTERNAL LENGTH LE (mm)
SPB 3350	3372
SPB 3450	3472
SPB 3550	3572
SPB 3650	3672
SPB 3750	3772
SPB 3800	3822
SPB 4000	4022
SPB 4050	4072
SPB 4250	4272
SPB 4300	4322
SPB 4500	4522
SPB 4560	4582
SPB 4750	4772
SPB 4820	4842
SPB 5000	5022
SPB 5070	5092
SPB 5300	5322
SPB 5600	5622
SPB 6000	6022
SPB 6300	6322
SPB 6700	6722
SPB 7100	7122
SPB 7500	7522
SPB 8000	8022

# NARROW WRAPPED

## V-BELTS DIN | EXTRA

**TABLE 4 -  $P_b$  (kW) referred to  $\emptyset$  (mm)**

RPM / $\emptyset$	140	150	160	170	180	190	200	212	224	236	250	265	280
100	0,74	0,84	0,94	1,04	1,14	1,24	1,33	1,45	1,57	1,69	1,82	1,97	2,11
200	1,35	1,54	1,73	1,92	2,11	2,30	2,49	2,71	2,93	3,16	3,41	3,69	3,96
500	2,95	3,39	3,84	4,28	4,72	5,16	5,59	6,12	6,63	7,15	7,74	8,38	9,01
700	3,90	4,51	5,11	5,71	6,31	6,90	7,49	8,19	8,89	9,59	10,39	11,25	12,09
900	4,79	5,55	6,30	7,06	7,80	8,54	9,28	10,15	11,02	11,88	12,88	13,93	14,97
1.000	5,21	6,04	6,88	7,70	8,52	9,33	10,13	11,09	12,04	12,98	14,06	15,21	16,34
1.400	6,77	7,89	8,99	10,09	11,17	12,24	13,29	14,54	15,78	16,99	18,38	19,83	21,26
1.500	7,12	8,31	9,48	10,64	11,78	12,91	14,02	15,33	16,63	17,90	19,35	20,86	22,34
1.700	7,80	9,12	10,41	11,68	12,94	14,17	15,39	16,82	18,22	19,59	21,14	22,76	24,32
1.800	8,12	9,50	10,85	12,18	13,48	14,77	16,03	17,51	18,96	20,37	21,97	23,62	25,21
2.000	8,73	10,21	11,67	13,11	14,51	15,88	17,22	18,79	20,32	21,79	23,45	25,15	26,77
2.500	10,00	11,74	13,42	15,05	16,64	18,17	19,65	21,35	22,96	24,49	26,15	27,79	
2.900	10,77	12,65	14,46	16,20	17,86	19,44	20,94	22,63	24,20				
3.000	10,93	12,83	14,66	16,42	18,09	19,67	21,17	22,84					
3.500	11,45	13,46	15,35	17,12	18,77	20,28							
3.600	11,51	13,52	15,41	17,18	18,80								

**$P_a$  (kW) referred to  $i$**

RPM / $i$	1,00/1,01	1,02/1,05	1,06/1,11	1,12/1,18	1,19/1,26	1,27/1,38	1,39/1,57	1,58/1,94	1,95/3,38	OVER 3,39
100	0,00	0,01	0,02	0,03	0,04	0,04	0,05	0,06	0,06	0,07
200	0,00	0,01	0,03	0,05	0,07	0,09	0,10	0,12	0,13	0,14
500	0,00	0,03	0,08	0,13	0,18	0,22	0,26	0,29	0,32	0,34
700	0,00	0,04	0,11	0,19	0,26	0,31	0,36	0,41	0,45	0,47
900	0,00	0,05	0,14	0,24	0,33	0,40	0,47	0,53	0,57	0,61
1.000	0,00	0,06	0,15	0,27	0,37	0,44	0,52	0,59	0,64	0,68
1.400	0,00	0,08	0,22	0,38	0,51	0,62	0,73	0,82	0,89	0,95
1.500	0,00	0,09	0,23	0,40	0,55	0,67	0,78	0,88	0,96	1,01
1.700	0,00	0,10	0,26	0,46	0,62	0,75	0,88	1,00	1,08	1,15
1.800	0,00	0,10	0,28	0,48	0,66	0,80	0,94	1,05	1,15	1,22
2.000	0,00	0,11	0,31	0,54	0,73	0,89	1,04	1,17	1,28	1,35
2.500	0,00	0,14	0,39	0,67	0,92	1,11	1,30	1,46	1,59	1,69
2.900	0,00	0,16	0,45	0,78	1,06	1,29	1,51	1,70	1,85	1,96
3.000	0,00	0,17	0,46	0,81	1,10	1,33	1,56	1,76	1,91	2,03
3.500	0,00	0,20	0,54	0,94	1,28	1,55	1,82	2,05	2,23	2,36
3.600	0,00	0,20	0,56	0,97	1,32	1,60	1,87	2,11	2,30	2,43

Belt speed is greater than 30 m/s then is necessary to use dynamically balanced pulleys. A reduction in belt life can be expected. Suggested a smaller section.

# NARROW WRAPPED

## V-BELTS DIN | OLEOSTATIC GOLD

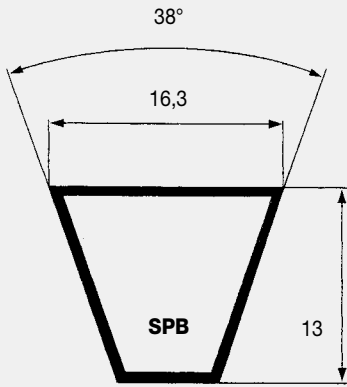

SPB SECTION	
CODE	EXTERNAL LENGTH LE (mm)
SPB 1250	1272
SPB 1320	1342
SPB 1400	1422
SPB 1410	1432
SPB 1450	1472
SPB 1500	1522
SPB 1600	1622
SPB 1650	1672
SPB 1700	1722
SPB 1750	1772
SPB 1800	1822
SPB 1850	1872
SPB 1860	1882
SPB 1900	1922
SPB 1950	1972
SPB 2000	2022
SPB 2020	2042
SPB 2060	2082
SPB 2098	2120
SPB 2120	2142
SPB 2150	2172
SPB 2180	2202
SPB 2240	2262
SPB 2264	2286
SPB 2280	2302

SPB SECTION	
CODE	EXTERNAL LENGTH LE (mm)
SPB 2300	2322
SPB 2360	2382
SPB 2391	2413
SPB 2400	2422
SPB 2410	2432
SPB 2430	2452
SPB 2450	2472
SPB 2500	2522
SPB 2530	2552
SPB 2580	2602
SPB 2600	2622
SPB 2650	2672
SPB 2680	2702
SPB 2720	2742
SPB 2800	2822
SPB 2840	2862
SPB 2850	2872
SPB 2900	2922
SPB 2950	2972
SPB 3000	3022
SPB 3070	3092
SPB 3150	3172
SPB 3170	3192
SPB 3250	3272
SPB 3320	3342

SPB SECTION	
CODE	EXTERNAL LENGTH LE (mm)
SPB 3350	3372
SPB 3450	3472
SPB 3550	3572
SPB 3650	3672
SPB 3750	3772
SPB 3800	3822
SPB 4000	4022
SPB 4050	4072
SPB 4250	4272
SPB 4300	4322
SPB 4500	4522
SPB 4560	4582
SPB 4750	4772
SPB 4820	4842
SPB 5000	5022
SPB 5070	5092
SPB 5300	5322
SPB 5600	5622
SPB 6000	6022
SPB 6300	6322
SPB 6700	6722
SPB 7100	7122
SPB 7500	7522
SPB 8000	8022

# NARROW WRAPPED

## V-BELTS DIN | OLEOSTATIC GOLD

**TABLE 4 - P<sub>b</sub> (kW) referred to Ø (mm)**

RPM / Ø	140	150	160	170	180	200	225	250	280	315	355	400
100	0,73	0,84	0,95	1,06	1,17	1,38	1,65	1,92	2,24	2,61	3,03	3,50
200	1,34	1,55	1,76	1,97	2,18	2,60	3,12	3,63	4,25	4,96	5,76	6,66
500	2,96	3,46	3,96	4,45	4,95	5,93	7,15	8,35	9,78	11,43	13,29	15,35
700	3,93	4,61	5,29	5,97	6,64	7,98	9,63	11,25	13,18	15,38	17,85	20,56
900	4,84	5,70	6,55	7,40	8,24	9,91	11,96	13,98	16,35	19,05	22,04	25,28
1.000	5,27	6,22	7,15	8,08	9,01	10,84	13,08	15,28	17,85	20,77	23,98	27,42
1.400	6,86	8,13	9,38	10,62	11,84	14,25	17,16	19,98	23,22	26,78	30,55	34,37
1.500	7,23	8,57	9,89	11,20	12,49	15,02	18,08	21,02	24,38	28,04	31,86	35,64*
1.700	7,91	9,40	10,86	12,30	13,72	16,48	19,79	22,94	26,47	30,23	34,01*	
1.800	8,24	9,79	11,31	12,82	14,29	17,16	20,58	23,80	27,39	31,16	34,85*	
2.000	8,83	10,51	12,16	13,77	15,35	18,40	22,00	25,33	28,96	32,62*		
2.500	10,06	12,00	13,89	15,72	17,49	20,82	24,59	27,87*				
2.900	10,73	12,83	14,84	16,76	18,59	21,95*	25,54*					
3.000	10,85	12,98	15,01	16,95	18,78	22,11*						
3.500	11,16	13,36	15,43	17,34*	19,09*							
3.600	11,16	13,36	15,42	17,31*	19,02*							
4.000	10,92	13,09*	15,05*									
4.600	9,82*											

**P<sub>a</sub> (kW) referred to i**

RPM / i	1,00/1,01	1,02/1,05	1,06/1,11	1,12/1,18	1,19/1,26	1,27/1,38	1,39/1,57	1,58/1,94	1,95/3,38	OVER 3,39
100	0,00	0,01	0,02	0,03	0,05	0,06	0,07	0,08	0,08	0,09
200	0,00	0,01	0,04	0,07	0,09	0,11	0,13	0,15	0,16	0,17
500	0,00	0,04	0,10	0,17	0,24	0,28	0,33	0,38	0,41	0,43
700	0,00	0,05	0,14	0,24	0,33	0,40	0,47	0,53	0,57	0,61
900	0,00	0,07	0,18	0,31	0,42	0,51	0,60	0,68	0,74	0,78
1.000	0,00	0,07	0,20	0,35	0,47	0,57	0,67	0,75	0,82	0,87
1.400	0,00	0,10	0,28	0,48	0,66	0,80	0,93	1,05	1,15	1,21
1.500	0,00	0,11	0,30	0,52	0,71	0,85	1,00	1,13	1,23	1,30
1.700	0,00	0,12	0,34	0,59	0,80	0,97	1,13	1,28	1,39	1,47
1.800	0,00	0,13	0,36	0,62	0,85	1,03	1,20	1,35	1,47	1,56
2.000	0,00	0,15	0,40	0,69	0,94	1,14	1,34	1,50	1,64	1,73
2.500	0,00	0,18	0,50	0,86	1,18	1,42	1,67	1,88	2,05	2,17
2.900	0,00	0,21	0,57	1,00	1,36	1,65	1,94	2,18	2,37	2,51
3.000	0,00	0,22	0,59	1,04	1,41	1,71	2,00	2,25	2,46	2,60
3.500	0,00	0,25	0,69	1,21	1,65	1,99	2,34	2,63	2,86	3,03
3.600	0,00	0,26	0,71	1,24	1,69	2,05	2,40	2,70	2,95	3,12
4.000	0,00	0,29	0,79	1,38	1,88	2,28	2,67	3,01	3,27	3,47
4.600	0,00	0,33	0,91	1,59	2,16	2,62	3,07	3,46	3,76	3,99

\* Belt speed is greater than 30 m/s then is necessary to use dynamically balanced pulleys. A reduction in belt life can be expected. Suggested a smaller section.

# NARROW WRAPPED

## V-BELTS DIN | EXTRA

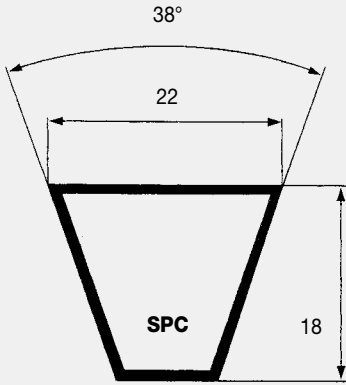

SPC SECTION	
CODE	EXTERNAL LENGTH LE (mm)
SPC 2000	2030
SPC 2120	2150
SPC 2240	2270
SPC 2360	2390
SPC 2500	2530
SPC 2650	2680
SPC 2800	2830
SPC 3000	3030
SPC 3150	3180
SPC 3350	3380
SPC 3550	3580
SPC 3750	3780

SPC SECTION	
CODE	EXTERNAL LENGTH LE (mm)
SPC 4000	4030
SPC 4250	4280
SPC 4400	4430
SPC 4500	4530
SPC 4750	4780
SPC 5000	5030
SPC 5300	5330
SPC 5600	5630
SPC 6000	6030
SPC 6300	6330
SPC 6700	6730
SPC 7100	7130

SPC SECTION	
CODE	EXTERNAL LENGTH LE (mm)
SPC 7500	7530
SPC 8000	8030
SPC 8500	8530
SPC 9000	9030
SPC 9500	9530
SPC 10000	10030
SPC 10600	10630
SPC 11200	11230
SPC 11800	11830
SPC 12000	12030
SPC 12500	12530

# NARROW WRAPPED

## V-BELTS DIN | EXTRA

**TABLE 4 - P<sub>b</sub> (kW) referred to Ø (mm)**

RPM / Ø	224	236	250	265	280	300	315	335	355	375	400	425	450	475
100	2,32	2,53	2,78	3,05	3,31	3,66	3,92	4,26	4,61	4,95	5,38	5,80	6,23	6,65
150	3,30	3,61	3,97	4,36	4,74	5,25	5,63	6,13	6,63	7,13	7,75	8,36	8,98	9,59
200	4,24	4,64	5,11	5,61	6,11	6,77	7,26	7,92	8,57	9,22	10,02	10,83	11,62	12,41
300	6,00	6,59	7,27	7,99	8,71	9,67	10,38	11,33	12,27	13,20	14,37	15,52	16,67	17,80
400	7,65	8,41	9,30	10,24	11,17	12,41	13,34	14,56	15,78	16,98	18,48	19,96	21,44	22,90
600	10,71	11,81	13,08	14,42	15,76	17,53	18,85	20,58	22,31	24,01	26,11	28,19	30,25	32,27
700	12,14	13,39	14,84	16,38	17,91	19,92	21,42	23,39	25,34	27,27	29,65	31,98	34,28	36,54
750	12,83	14,16	15,70	17,33	18,95	21,08	22,66	24,75	26,81	28,84	31,34	33,79	36,20	38,57
900	14,81	16,36	18,15	20,05	21,92	24,39	26,21	28,61	30,96	33,28	36,11	38,87	41,57	44,19
1.000	16,06	17,74	19,69	21,75	23,79	26,45	28,42	31,00	33,53	36,01	39,02	41,95	44,78	47,52
1.400	20,43	22,60	25,09	27,70	30,25	33,56	35,96	39,06	42,04	44,89	48,27	51,44	54,37	57,07
1.500	21,37	23,64	26,24	28,96	31,61	35,02	37,49	40,66	43,68	46,55	49,92	53,02		
1.700	23,04	25,49	28,28	31,17	33,96	37,52	40,07	43,29	46,31	49,11				
1.800	23,78	26,30	29,16	32,12	34,96	38,56	41,11	44,32	47,28					
2.000	25,03	27,67	30,64	33,67	36,56	40,15	42,65							
2.500	26,79	29,52	32,48	35,40										

**P<sub>a</sub> (kW) referred to i**

RPM / i	1,00/1,01	1,02/1,05	1,06/1,11	1,12/1,18	1,19/1,26	1,27/1,38	1,39/1,57	1,58/1,94	1,95/3,38	OVER 3,39
100	0,00	0,02	0,04	0,07	0,10	0,12	0,14	0,16	0,18	0,19
150	0,00	0,02	0,06	0,11	0,15	0,18	0,22	0,24	0,27	0,28
200	0,00	0,03	0,09	0,15	0,20	0,25	0,29	0,33	0,35	0,38
300	0,00	0,05	0,13	0,22	0,31	0,37	0,43	0,49	0,53	0,56
400	0,00	0,06	0,17	0,30	0,41	0,49	0,58	0,65	0,71	0,75
600	0,00	0,09	0,26	0,45	0,61	0,74	0,87	0,98	1,06	1,13
700	0,00	0,11	0,30	0,52	0,71	0,86	1,01	1,14	1,24	1,31
750	0,00	0,12	0,32	0,56	0,76	0,92	1,08	1,22	1,33	1,41
900	0,00	0,14	0,39	0,67	0,92	1,11	1,30	1,46	1,59	1,69
1.000	0,00	0,16	0,43	0,75	1,02	1,23	1,44	1,63	1,77	1,88
1.400	0,00	0,22	0,60	1,05	1,42	1,73	2,02	2,28	2,48	2,63
1.500	0,00	0,24	0,64	1,12	1,53	1,85	2,17	2,44	2,66	2,81
1.700	0,00	0,27	0,73	1,27	1,73	2,10	2,46	2,76	3,01	3,19
1.800	0,00	0,28	0,77	1,35	1,83	2,22	2,60	2,93	3,19	3,38
2.000	0,00	0,31	0,86	1,49	2,03	2,47	2,89	3,25	3,54	3,75
2.500	0,00	0,39	1,07	1,87	2,54	3,08	3,61	4,06	4,43	4,69

Belt speed is greater than 30 m/s then is necessary to use dynamically balanced pulleys. A reduction in belt life can be expected. Suggested a smaller section.

# NARROW WRAPPED

## V-BELTS DIN | OLEOSTATIC GOLD

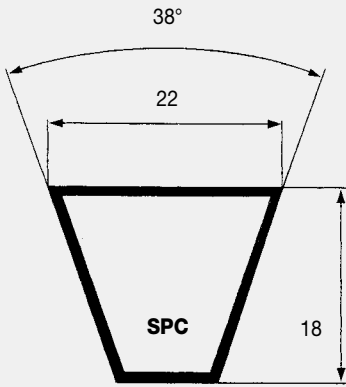

SPC SECTION	
CODE	EXTERNAL LENGTH LE (mm)
SPC 2000	2030
SPC 2120	2150
SPC 2240	2270
SPC 2360	2390
SPC 2500	2530
SPC 2650	2680
SPC 2800	2830
SPC 3000	3030
SPC 3150	3180
SPC 3350	3380
SPC 3550	3580
SPC 3750	3780

SPC SECTION	
CODE	EXTERNAL LENGTH LE (mm)
SPC 4000	4030
SPC 4250	4280
SPC 4400	4430
SPC 4500	4530
SPC 4750	4780
SPC 5000	5030
SPC 5300	5330
SPC 5600	5630
SPC 6000	6030
SPC 6300	6330
SPC 6700	6730
SPC 7100	7130

SPC SECTION	
CODE	EXTERNAL LENGTH LE (mm)
SPC 7500	7530
SPC 8000	8030
SPC 8500	8530
SPC 9000	9030
SPC 9500	9530
SPC 10000	10030
SPC 10600	10630
SPC 11200	11230
SPC 11800	11830
SPC 12000	12030
SPC 12500	12530

# NARROW WRAPPED

## V-BELTS DIN | OLEOSTATIC GOLD

**TABLE 4 - P<sub>b</sub> (kW) referred to Ø (mm)**

RPM / Ø	224	236	250	280	315	355	400	450	500	560	600	630
50	1,21	1,34	1,48	1,79	2,15	2,56	3,01	3,52	4,01	4,61	5,01	5,30
100	2,26	2,50	2,77	3,37	4,06	4,84	5,72	6,69	7,64	8,79	9,55	10,11
150	3,23	3,59	3,99	4,87	5,88	7,02	8,31	9,72	11,12	12,79	13,89	14,72
200	4,17	4,63	5,17	6,31	7,63	9,13	10,81	12,65	14,48	16,66	18,10	19,17
300	5,94	6,62	7,40	9,07	11,00	13,19	15,62	18,30	20,94	24,08	26,15	27,69
400	7,62	8,50	9,53	11,70	14,22	17,06	20,21	23,67	27,08	31,09	33,73	35,69
600	10,75	12,03	13,51	16,64	20,25	24,30	28,77	33,62	38,34	43,83	47,37	49,97
700	12,22	13,68	15,37	18,96	23,08	27,68	32,73	38,17	43,43	49,47	53,33	56,13
750	12,92	14,48	16,28	20,08	24,44	29,30	34,62	40,33	45,82	52,09	56,06	58,92
900	14,95	16,77	18,86	23,29	28,32	33,90	39,94	46,32	52,34	59,04	63,17	66,08
1.000	16,22	18,20	20,49	25,29	30,74	36,73	43,15	49,86	56,09	62,87	66,93*	69,72*
1.400	20,60	23,16	26,07	32,12	38,77	45,81	52,95		65,40*			
1.500	21,52	24,18	27,23	33,49	40,33	47,46	54,53*					
1.700	23,10	25,96	29,21	35,81	42,84	49,91*						
1.800	23,76	26,70	30,03	36,73	43,77							
2.000	24,81	27,87	31,30	38,07								
2.500	25,68	28,76*	32,08*									

**P<sub>a</sub> (kW) referred to i**

RPM / i	1,00/1,01	1,02/1,05	1,06/1,11	1,12/1,18	1,19/1,26	1,27/1,38	1,39/1,57	1,58/1,94	1,95/3,38	OVER 3,39
50	0,00	0,01	0,03	0,05	0,06	0,08	0,09	0,10	0,11	0,12
100	0,00	0,02	0,05	0,09	0,13	0,15	0,18	0,20	0,22	0,23
150	0,00	0,03	0,08	0,14	0,19	0,23	0,27	0,30	0,33	0,35
200	0,00	0,04	0,11	0,19	0,25	0,31	0,36	0,41	0,44	0,47
300	0,00	0,06	0,16	0,28	0,38	0,46	0,54	0,61	0,66	0,70
400	0,00	0,08	0,21	0,37	0,51	0,62	0,72	0,81	0,88	0,94
600	0,00	0,12	0,32	0,56	0,76	0,92	1,08	1,22	1,33	1,40
700	0,00	0,14	0,37	0,65	0,89	1,08	1,26	1,42	1,55	1,64
750	0,00	0,15	0,40	0,70	0,95	1,15	1,35	1,52	1,66	1,76
900	0,00	0,18	0,48	0,84	1,14	1,39	1,62	1,83	1,99	2,11
1.000	0,00	0,20	0,54	0,93	1,27	1,54	1,80	2,03	2,21	2,34
1.400	0,00	0,28	0,75	1,31	1,78	2,15	2,52	2,84	3,09	3,28
1.500	0,00	0,29	0,80	1,40	1,91	2,31	2,70	3,04	3,32	3,51
1.700	0,00	0,33	0,91	1,59	2,16	2,62	3,06	3,45	3,76	3,98
1.800	0,00	0,35	0,96	1,68	2,29	2,77	3,24	3,65	3,98	4,21
2.000	0,00	0,39	1,07	1,87	2,54	3,08	3,61	4,06	4,42	4,68
2.500	0,00	0,49	1,34	2,33	3,18	3,85	4,51	5,07	5,53	5,85

\* Belt speed is greater than 30 m/s then is necessary to use dynamically balanced pulleys. A reduction in belt life can be expected. Suggested a smaller section.



MEGADYNE V-BELTS

# NARROW WRAPPED V-BELTS ARPM

OLEOSTATIC

# NARROW WRAPPED

## V-BELTS ARPM | OLEOSTATIC

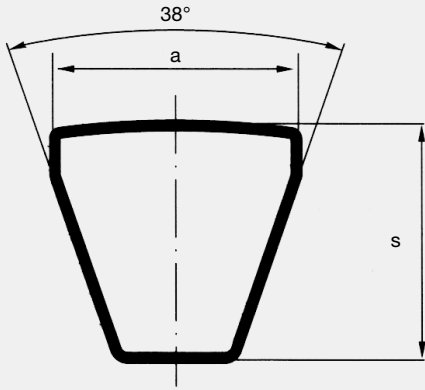

BELT CHARACTERISTICS			
SECTION	3V	5V	8V
a (mm)	9	15	25
s (mm)	8	13	23
Pitch length - internal length = $\Delta i$ (mm)	31	54	103
External length - pitch length = $\Delta e$ (mm)	20	27	41
Weigth (gr/m)	90	210	620
Min. Pulley diam. (Mm)	50	170	315
Working temperature	-30°C / +80°C		
Relevant standards	ARPM/MTPA IP22 - ASAE S 211-4		
Relevant antistatic standard	ISO 1813		
Materials	CR blend - polyester cord - cotton/polyester fabric		

TABLE 3 - CORRECTION FACTOR $C_L$ (according to type and length of the belt)																					
	635	850	1080	1205	1270	1700	2030	2415	2690	3175	3555	3810	4570	5690	8000	8500	9000	10800	12060	12700	
3V	0,83	0,88	0,93	0,95	0,96	1,01	1,04	1,08	1,10	1,13	1,15										
5V					0,85	0,90	0,93	0,96	0,97	1,00	1,02	1,03	1,06	1,09	1,15	1,16	1,17				
8V									0,88	0,90	0,92	0,93	0,95	0,98	1,03	1,04	1,05	1,08	1,09	1,10	

TABLE 5 - INSTALLATION AND TAKE UP ALLOWANCE				
L (mm)	Y (mm)			X (mm)
	3V	5V	8V	
635 / 1145	15			25
1205 / 3555	20	25	40	55
3810 / 5080		25	45	65
5385 / 6350		35	45	105
6730 / 9000		35	50	105
9500 / 12700			50	140

# NARROW WRAPPED

## V-BELTS ARPM | OLEOSTATIC

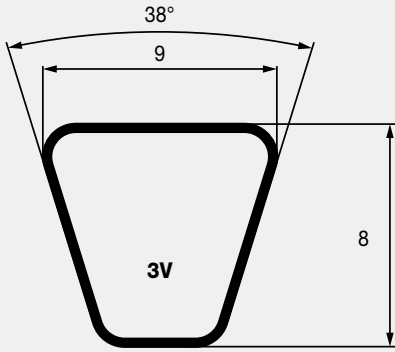

3V SECTION	
CODE	EXTERNAL LENGTH LE (mm)
3V250	635
3V265	675
3V280	710
3V300	760
3V315	800
3V335	850
3V355	900
3V375	955
3V400	1015
3V425	1080
3V450	1145

3V SECTION	
CODE	EXTERNAL LENGTH LE (mm)
3V475	1205
3V500	1270
3V530	1345
3V560	1420
3V600	1525
3V630	1600
3V670	1700
3V710	1805
3V750	1905
3V800	2030
3V850	2160

3V SECTION	
CODE	EXTERNAL LENGTH LE (mm)
3V900	2285
3V950	2415
3V1000	2540
3V1060	2690
3V1120	2845
3V1180	2995
3V1250	3175
3V1320	3355
3V1400	3555
3V1500	3810

# NARROW WRAPPED

## V-BELTS ARPM | OLEOSTATIC

**TABLE 4 -  $P_b$  (kW) referred to  $\emptyset$  (mm)**

RPM / $\emptyset$	63	71	80	90	100	112	125	140	150	160	170	180
100	0,10	0,13	0,16	0,20	0,24	0,28	0,33	0,38	0,41	0,45	0,48	0,52
200	0,18	0,24	0,30	0,37	0,44	0,52	0,61	0,71	0,78	0,85	0,91	0,98
500	0,39	0,52	0,67	0,83	0,99	1,19	1,39	1,63	1,79	1,94	2,10	2,25
700	0,51	0,69	0,89	1,11	1,34	1,60	1,88	2,20	2,42	2,63	2,84	3,05
900	0,62	0,85	1,10	1,38	1,66	1,99	2,35	2,75	3,02	3,28	3,55	3,81
1.000	0,67	0,92	1,20	1,51	1,82	2,18	2,57	3,02	3,31	3,60	3,89	4,17
1.400	0,87	1,21	1,59	2,01	2,42	2,92	3,44	4,03	4,43	4,81	5,19	5,57
1.500	0,91	1,28	1,68	2,13	2,57	3,09	3,65	4,28	4,69	5,10	5,50	5,90
1.700	1,00	1,41	1,86	2,36	2,85	3,43	4,05	4,75	5,21	5,66	6,10	6,54
1.800	1,04	1,47	1,95	2,47	2,99	3,60	4,25	4,98	5,46	5,93	6,39	6,84
2.500	1,31	1,88	2,52	3,21	3,89	4,68	5,52	6,45	7,05	7,63	8,19	8,74
2.900	1,44	2,09	2,81	3,59	4,35	5,23	6,16	7,17	7,82	8,44	9,04	9,60
3.000	1,47	2,14	2,88	3,68	4,46	5,36	6,31	7,34	8,00	8,63	9,22	9,79
3.400	1,58	2,32	3,14	4,02	4,87	5,85	6,86	7,95	8,63	9,27	9,87	10,43*
3.600	1,63	2,41	3,26	4,18	5,06	6,07	7,11	8,22	8,90	9,54	10,13*	10,68*
4.000	1,72	2,57	3,49	4,47	5,41	6,47	7,55	8,67	9,35*	9,97*		
5.000	1,88	2,87	3,93	5,04	6,07	7,19	8,26*					
6.000	1,94	3,03	4,18	5,35	6,39*							

**$P_a$  (kW) referred to  $i$**

RPM / $i$	1,00/1,01	1,02/1,05	1,06/1,11	1,12/1,18	1,19/1,26	1,27/1,38	1,39/1,57	1,58/1,94	1,95/3,38	OVER 3,39
100	0,00	0,00	0,00	0,01	0,01	0,01	0,01	0,01	0,02	0,02
200	0,00	0,00	0,01	0,01	0,02	0,02	0,03	0,03	0,03	0,03
500	0,00	0,01	0,02	0,03	0,05	0,06	0,06	0,07	0,08	0,08
700	0,00	0,01	0,03	0,05	0,06	0,08	0,09	0,10	0,11	0,12
900	0,00	0,01	0,03	0,06	0,08	0,10	0,12	0,13	0,14	0,15
1.000	0,00	0,01	0,04	0,07	0,09	0,11	0,13	0,15	0,16	0,17
1.400	0,00	0,02	0,05	0,09	0,13	0,15	0,18	0,20	0,22	0,23
1.500	0,00	0,02	0,06	0,10	0,14	0,17	0,19	0,22	0,24	0,25
1.700	0,00	0,02	0,07	0,11	0,15	0,19	0,22	0,25	0,27	0,29
1.800	0,00	0,03	0,07	0,12	0,16	0,20	0,23	0,26	0,29	0,30
2.500	0,00	0,04	0,10	0,17	0,23	0,28	0,32	0,36	0,40	0,42
2.900	0,00	0,04	0,11	0,19	0,26	0,32	0,37	0,42	0,46	0,49
3.000	0,00	0,04	0,12	0,20	0,27	0,33	0,39	0,44	0,48	0,50
3.400	0,00	0,05	0,13	0,23	0,31	0,38	0,44	0,49	0,54	0,57
3.600	0,00	0,05	0,14	0,24	0,33	0,40	0,47	0,52	0,57	0,60
4.000	0,00	0,06	0,15	0,27	0,36	0,44	0,52	0,58	0,63	0,67
5.000	0,00	0,07	0,19	0,33	0,46	0,55	0,65	0,73	0,79	0,84
6.000	0,00	0,08	0,23	0,40	0,55	0,66	0,78	0,87	0,95	1,01

\* Belt speed is greater than 30 m/s then is necessary to use dynamically balanced pulleys. A reduction in belt life can be expected. Suggested a smaller section.

# NARROW WRAPPED

## V-BELTS ARPM | OLEOSTATIC

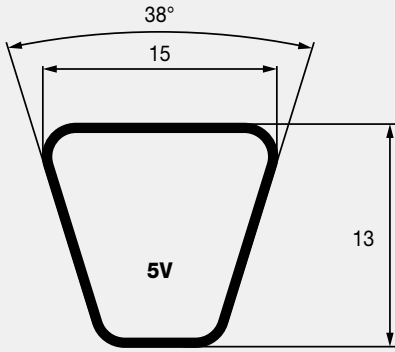

5V SECTION	
CODE	EXTERNAL LENGTH LE (mm)
5V500	1270
5V530	1345
5V560	1420
5V600	1525
5V630	1600
5V670	1700
5V710	1800
5V750	1900
5V800	2030
5V850	2160
5V900	2290
5V950	2410

5V SECTION	
CODE	EXTERNAL LENGTH LE (mm)
5V1000	2540
5V1060	2690
5V1120	2840
5V1180	3000
5V1250	3180
5V1320	3350
5V1400	3550
5V1500	3810
5V1600	4060
5V1700	4320
5V1800	4570
5V1900	4830

5V SECTION	
CODE	EXTERNAL LENGTH LE (mm)
5V2000	5080
5V2120	5380
5V2240	5690
5V2360	6000
5V2500	6350
5V2650	6730
5V2800	7100
5V3000	7620
5V3150	8000
5V3350	8500
5V3550	9000

# NARROW WRAPPED

## V-BELTS ARPM | OLEOSTATIC

**TABLE 4 - P<sub>b</sub> (kW) referred to Ø (mm)**

RPM / Ø	140	150	160	170	180	200	225	250	280	315	355	400
100	0,66	0,75	0,85	0,94	1,04	1,22	1,45	1,69	1,96	2,28	2,64	3,04
200	1,20	1,38	1,56	1,74	1,92	2,28	2,7	3,16	3,68	4,29	4,97	5,74
500	2,60	3,02	3,45	3,87	4,29	5,12	6,11	7,16	8,37	9,76	11,33	13,06
700	3,43	4	4,58	5,15	5,72	6,85	8,18	9,61	11,23	13,08	15,16	17,43
900	4,19	4,92	5,64	6,35	7,06	8,47	10,13	11,89	13,88	16,15	18,66	21,38
1.000	4,56	5,35	6,14	6,93	7,71	9,24	11,05	12,98	15,14	17,59	20,29	23,18
1.400	5,88	6,95	8	9,04	10,07	12,09	14,44	16,9	19,62	22,62	25,81	29,05
1.500	6,19	7,31	8,43	9,53	10,61	12,73	15,2	17,77	20,6	23,68	26,92	30,14*
1.700	6,75	8	9,23	10,44	11,63	13,95	16,62	19,38	22,36	25,54	28,77*	
1.800	7,02	8,32	9,6	10,86	12,1	14,51	17,27	20,1	23,13	26,33	29,49*	
2.000	7,51	8,92	10,3	11,66	12,98	15,55	18,46	21,39	24,47	27,60*		
2.500	8,51	10,14	11,73	13,27	14,76	17,58	20,65	23,58*				
2.900	9,05	10,82	12,52	14,14	15,69	18,55*	21,52*					
3.000	9,15	10,94	12,66	14,3	15,85	18,69*						
3.500	9,40	11,27	13,02	14,65*	16,16*							
3.600	9,40	11,27	13,02	14,64*	16,12*							
4.000	9,21	11,06*	12,75*									
4.600	8,33*											

**P<sub>a</sub> (kW) referred to i**

RPM / I	1,00/1,01	1,02/1,05	1,06/1,11	1,12/1,18	1,19/1,26	1,27/1,38	1,39/1,57	1,58/1,94	1,95/3,38	OVER 3,39
100	0,00	0,01	0,02	0,03	0,05	0,06	0,07	0,07	0,08	0,09
200	0,00	0,01	0,04	0,07	0,09	0,11	0,13	0,15	0,16	0,17
500	0,00	0,04	0,10	0,17	0,23	0,28	0,33	0,37	0,41	0,43
700	0,00	0,05	0,14	0,24	0,33	0,40	0,47	0,52	0,57	0,61
900	0,00	0,07	0,18	0,31	0,42	0,51	0,60	0,67	0,73	0,78
1000	0,00	0,07	0,20	0,34	0,47	0,57	0,67	0,75	0,82	0,86
1400	0,00	0,10	0,28	0,48	0,66	0,80	0,93	1,05	1,14	1,21
1500	0,00	0,11	0,30	0,52	0,70	0,85	1,00	1,12	1,22	1,30
1700	0,00	0,12	0,34	0,59	0,80	0,97	1,13	1,27	1,39	1,47
1800	0,00	0,13	0,36	0,62	0,84	1,02	1,20	1,35	1,47	1,56
2000	0,00	0,15	0,40	0,69	0,94	1,14	1,33	1,50	1,63	1,73
2500	0,00	0,18	0,49	0,86	1,17	1,42	1,66	1,87	2,04	2,16
2900	0,00	0,21	0,57	1,00	1,36	1,65	1,93	2,17	2,37	2,51
3000	0,00	0,22	0,59	1,03	1,41	1,71	2,00	2,25	2,45	2,59
3500	0,00	0,25	0,69	1,21	1,64	1,99	2,33	2,62	2,86	3,03
3600	0,00	0,26	0,71	1,24	1,69	2,05	2,40	2,70	2,94	3,11
4000	0,00	0,29	0,79	1,38	1,88	2,27	2,66	3,00	3,27	3,46
4600	0,00	0,33	0,91	1,59	2,16	2,62	3,06	3,45	3,76	3,98

\* Belt speed is greater than 30 m/s then is necessary to use dynamically balanced pulleys. A reduction in belt life can be expected. Suggested a smaller section.

# NARROW WRAPPED

## V-BELTS ARPM | OLEOSTATIC

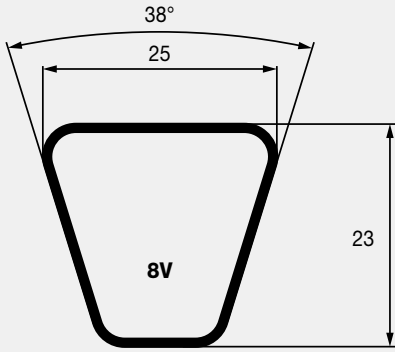

8V SECTION	
CODE	EXTERNAL LENGTH LE (mm)
8V1000	2540
8V1060	2690
8V1120	2840
8V1180	3000
8V1250	3180
8V1320	3350
8V1400	3550
8V1500	3810
8V1600	4060
8V1700	4320

8V SECTION	
CODE	EXTERNAL LENGTH LE (mm)
8V1800	4570
8V1900	4830
8V2000	5080
8V2120	5380
8V2240	5690
8V2360	6000
8V2500	6350
8V2650	6730
8V2800	7100
8V3000	7620

8V SECTION	
CODE	EXTERNAL LENGTH LE (mm)
8V3150	8000
8V3350	8500
8V3550	9000
8V3750	9500
8V4000	10160
8V4250	10800
8V4500	11430
8V4750	12060
8V5000	12700

# NARROW WRAPPED

## V-BELTS ARPM | OLEOSTATIC

**TABLE 4 - P<sub>b</sub> (kW) referred to Ø (mm)**

RPM / Ø	315	335	355	375	400	425	475	530	600	670	750	800
50	2,36	2,62	2,89	3,15	3,48	3,8	4,45	5,16	6,06	6,95	7,96	8,58
100	4,35	4,86	5,36	5,87	6,49	7,12	8,36	9,71	11,42	13,11	15,03	16,22
150	6,21	6,95	7,68	8,42	9,33	10,24	12,04	14,01	16,49	18,95	21,73	23,45
200	7,97	8,93	9,89	10,85	12,04	13,22	15,58	18,14	21,36	24,55	28,15	30,37
300	11,28	12,68	14,07	15,46	17,18	18,89	22,29	25,97	30,59	35,13	40,23	43,36
400	14,37	16,19	17,99	19,79	22,01	24,22	28,58	33,3	39,18	44,93	51,32	55,21
500	17,28	19,49	21,68	23,86	26,56	29,23	34,48	40,14	47,14	53,9	61,33	65,79
600	20,01	22,59	25,15	27,69	30,82	33,92	39,99	46,47	54,4	61,97	70,13	74,95
750	23,77	26,88	29,94	32,97	36,69	40,34	47,44	54,9	63,86	72,15	80,74	85,59*
900	27,15	30,71	34,21	37,65	41,86	45,96	53,83	61,94	71,36	79,69*		
1000	29,17	33	36,75	40,43	44,89	49,22	57,44	65,76	75,14*			
1200	32,61	36,89	41,03	45,05	49,87	54,47	62,93	71,05*				
1400	35,2	39,77	44,14	48,31	53,23	57,80*	65,83*					
1500	36,15	40,8	45,22	49,39	54,24*	58,68*						
1700	37,29	41,97	46,32*	50,32*								
1800	37,45	42,07*	46,31*									
1900	37,34*	41,84*										
2000	36,93*											

**P<sub>a</sub> (kW) referred to i**

RPM / I	1,00/1,01	1,02/1,05	1,06/1,11	1,12/1,18	1,19/1,26	1,27/1,38	1,39/1,57	1,58/1,94	1,95/3,38	OVER 3,39
50	0,00	0,02	0,05	0,09	0,13	0,16	0,18	0,21	0,22	0,24
100	0,00	0,04	0,11	0,19	0,26	0,31	0,37	0,41	0,45	0,47
150	0,00	0,06	0,16	0,28	0,39	0,47	0,55	0,62	0,67	0,71
200	0,00	0,08	0,22	0,38	0,52	0,62	0,73	0,82	0,90	0,95
300	0,00	0,12	0,32	0,57	0,77	0,94	1,10	1,24	1,35	1,42
400	0,00	0,16	0,43	0,76	1,03	1,25	1,46	1,65	1,79	1,90
500	0,00	0,20	0,54	0,94	1,29	1,56	1,83	2,06	2,24	2,37
600	0,00	0,24	0,65	1,13	1,55	1,87	2,19	2,47	2,69	2,85
750	0,00	0,30	0,81	1,42	1,93	2,34	2,74	3,09	3,36	3,56
900	0,00	0,36	0,97	1,70	2,32	2,81	3,29	3,71	4,04	4,27
1000	0,00	0,40	1,08	1,89	2,58	3,12	3,66	4,12	4,49	4,75
1200	0,00	0,48	1,30	2,27	3,09	3,75	4,39	4,94	5,38	5,70
1400	0,00	0,56	1,52	2,64	3,61	4,37	5,12	5,77	6,28	6,65
1500	0,00	0,60	1,62	2,83	3,87	4,68	5,49	6,18	6,73	7,12
1700	0,00	0,68	1,84	3,21	4,38	5,31	6,22	7,00	7,62	8,07
1800	0,00	0,72	1,95	3,40	4,64	5,62	6,58	7,41	8,07	8,55
1900	0,00	0,76	2,06	3,59	4,90	5,93	6,95	7,83	8,52	9,02
2000	0,00	0,79	2,17	3,78	5,15	6,24	7,32	8,24	8,97	9,50

\* Belt speed is greater than 30 m/s then is necessary to use dynamically balanced pulleys. A reduction in belt life can be expected. Suggested a smaller section.

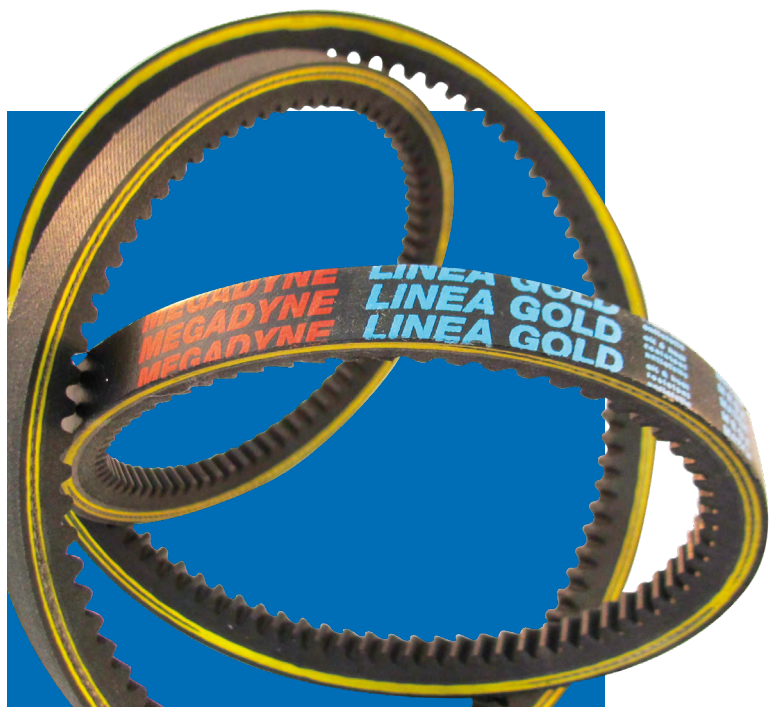

MEGADYNE V-BELTS

# CLASSICAL RAW EDGE V-BELTS

LINEA GOLD

# CLASSICAL RAW EDGE

## V-BELTS | LINEA GOLD

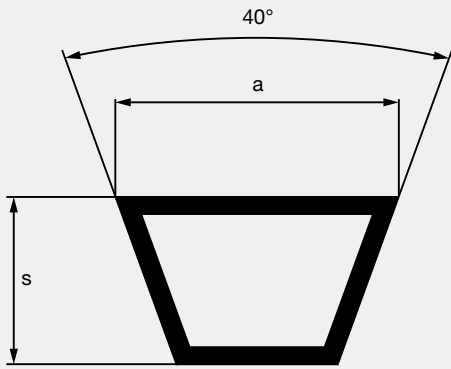

### BELT CHARACTERISTICS

SECTION	AX	BX	CX
a (mm)	13	17	22
s (mm)	8	11	14
Pitch length - internal length = $\Delta i$ (mm)	33	43	62
External length - pitch length = $\Delta e$ (mm)	17	26	26
Weigth (gr/m)	114	162	297
Min. Pulley diam. (Mm)	63	90	140
Working temperature	-40°C / +110°C		
Relevant standards	ARPM/MPTA IP20 - DIN 2215		
Relevant antistatic standard	ISO 1813		
Materials	EPDM compound - polyester cord		

**TABLE 3 - CORRECTION FACTOR  $C_L$  (according to type and length of the belt)**

	9½	16	22	24	28	32	35	48	53	75	81	90	128
<b>AX</b>		0,73	0,79	0,8	0,83	0,85	0,87	0,93	0,95	1,03	1,05	1,07	1,16
<b>BX</b>		0,98	0,73	0,75	0,77	0,8	0,81	0,87	0,89	0,96		1	1,08
<b>CX</b>						0,72	0,73	0,79	0,8	0,87	0,88	0,9	0,97

**TABLE 5 - INSTALLATION AND TAKE UP ALLOWANCE**

L (mm)	Y (mm)			X (mm)
	AX	BX	CX	
500 / 1000	19	25	-	25
1001 / 1500	19	25	38	38
1501 / 2500	19	32	38	51
2501 / 3000	25	32	38	63
3001 / 3500	25	38	38	75

# CLASSICAL RAW EDGE

## V-BELTS | LINEA GOLD

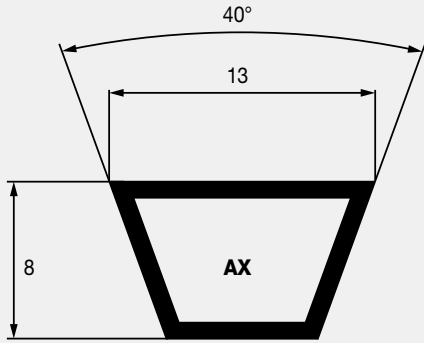

AX SECTION	
CODE	EXTERNAL LENGTH LE (mm)
AX21	585
AX22	610
AX23	635
AX24	665
AX25	690
AX26	710
AX27	750
AX28	765
AX29	800
AX30	815
AX31	850
AX32	865
AX33	900
AX34	915
AX35	950
AX36	965
AX37	1000
AX38	1020
AX39	1045
AX40	1075
AX41	1095
AX42	1120
AX43	1150
AX44	1170
AX45	1195
AX46	1230
AX47	1245
AX48	1270
AX49	1300
AX50	1325

AX SECTION	
CODE	EXTERNAL LENGTH LE (mm)
AX51	1350
AX52	1375
AX53	1400
AX54	1425
AX55	1450
AX56	1475
AX57	1500
AX58	1525
AX59	1550
AX60	1585
AX61	1600
AX62	1630
AX63	1655
AX64	1680
AX65	1710
AX66	1730
AX67	1760
AX68	1790
AX69	1810
AX70	1830
AX71	1865
AX72	1890
AX73	1905
AX74	1935
AX75	1965
AX76	1985
AX77	2010
AX78	2030
AX79	2060
AX80	2080

AX SECTION	
CODE	EXTERNAL LENGTH LE (mm)
AX81	2120
AX82	2140
AX83	2160
AX84	2190
AX85	2220
AX86	2240
AX87	2260
AX88	2290
AX89	2310
AX90	2350
AX91	2360
AX92	2390
AX93	2420
AX94	2440
AX95	2470
AX96	2500
AX97	2520
AX98	2540
AX100	2600
AX103	2670
AX105	2730
AX110	2850
AX112	2910
AX120	3110
AX128	3310
AX136	3510
AX144	3710
AX158	4070
AX173	4450
AX180	4620

# CLASSICAL RAW EDGE

## V-BELTS | LINEA GOLD

**TABLE 4 - P<sub>b</sub> (kW) referred to Ø (mm)**

RPM / Ø	63	67	71	80	90	100	112	125	140	160	180	200
100	0,16	0,18	0,20	0,24	0,28	0,32	0,37	0,43	0,49	0,57	0,64	0,72
200	0,28	0,31	0,34	0,41	0,49	0,57	0,66	0,76	0,87	1,01	1,15	1,29
500	0,53	0,61	0,68	0,83	1,00	1,17	1,37	1,58	1,82	2,13	2,43	2,73
700	0,67	0,76	0,86	1,06	1,29	1,51	1,77	2,05	2,36	2,77	3,17	3,55
900	0,78	0,90	1,01	1,27	1,55	1,82	2,14	2,48	2,86	3,36	3,84	4,31
1.000	0,83	0,96	1,08	1,36	1,67	1,96	2,31	2,68	3,10	3,64	4,16	4,67
1.400	1,00	1,17	1,33	1,70	2,09	2,48	2,94	3,42	3,96	4,65	5,32	5,97
1.500	1,03	1,21	1,39	1,77	2,19	2,60	3,08	3,59	4,15	4,88	5,59	6,27
1.700	1,10	1,29	1,49	1,91	2,38	2,83	3,35	3,91	4,53	5,33	6,09	6,83
1.800	1,13	1,33	1,53	1,98	2,46	2,93	3,48	4,06	4,71	5,54	6,33	7,09
2.500	1,27	1,54	1,80	2,37	2,99	3,59	4,29	5,01	5,81	6,82	7,77	8,66
2.900	1,32	1,62	1,91	2,55	3,24	3,90	4,66	5,46	6,33	7,42	8,42	9,33*
3.000	1,33	1,63	1,93	2,59	3,29	3,97	4,75	5,56	6,45	7,55	8,56	9,47*
3.500	1,35	1,69	2,02	2,75	3,53	4,28	5,14	6,01	6,96	8,11	9,13*	
3.600	1,35	1,70	2,04	2,78	3,58	4,34	5,20	6,09	7,04	8,20*	9,22*	
4.000	1,34	1,71	2,08	2,88	3,72	4,53	5,44	6,36	7,34	8,50*		
4.500	1,30	1,71	2,10	2,96	3,86	4,71	5,66	6,61	7,60*			
5.000	1,24	1,67	2,09	3,00	3,94	4,83	5,81	6,76*				

**P<sub>a</sub> (kW) referred to i**

RPM / I	1,00/1,01	1,02/1,05	1,06/1,26	1,27/1,57	OVER 1,57
100	0,00	0,00	0,01	0,02	0,02
200	0,00	0,00	0,02	0,03	0,04
500	0,00	0,01	0,05	0,08	0,09
700	0,00	0,01	0,08	0,11	0,13
900	0,00	0,02	0,10	0,14	0,17
1.000	0,00	0,02	0,11	0,16	0,19
1.400	0,00	0,02	0,15	0,22	0,26
1.500	0,00	0,03	0,16	0,23	0,28
1.700	0,00	0,03	0,18	0,26	0,32
1.800	0,00	0,03	0,20	0,28	0,34
2.500	0,00	0,04	0,27	0,39	0,47
2.900	0,00	0,05	0,31	0,45	0,55
3.000	0,00	0,05	0,33	0,47	0,57
3.500	0,00	0,06	0,38	0,54	0,66
3.600	0,00	0,06	0,39	0,56	0,68
4.000	0,00	0,07	0,43	0,62	0,75
4.500	0,00	0,08	0,49	0,70	0,85
5.000	0,00	0,08	0,54	0,78	0,94

\* Belt speed is greater than 30 m/s then is necessary to use dynamically balanced pulleys. A reduction in belt life can be expected. Suggested a smaller section.

# CLASSICAL RAW EDGE

## V-BELTS | LINEA GOLD

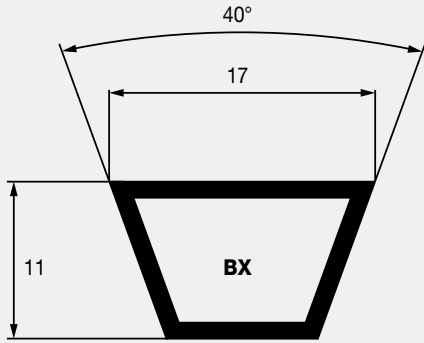

BX SECTION	
CODE	EXTERNAL LENGTH LE (mm)
BX28	785
BX30	835
BX32	885
BX33	908
BX34	935
BX35	960
BX36	990
BX37	1009
BX38	1040
BX39	1060
BX40	1090
BX41	1120
BX42	1140
BX43	1165
BX44	1190
BX45	1215
BX46	1250
BX47	1265
BX48	1295
BX49	1320
BX50	1345
BX51	1370
BX52	1400
BX53	1420
BX54	1445
BX55	1470
BX56	1500
BX57	1520
BX58	1545
BX59	1570
BX60	1600
BX61	1625

BX SECTION	
CODE	EXTERNAL LENGTH LE (mm)
BX62	1650
BX63	1675
BX64	1700
BX65	1725
BX66	1750
BX67	1775
BX68	1800
BX69	1825
BX70	1850
BX71	1875
BX72	1900
BX73	1930
BX74	1955
BX75	1980
BX76	2000
BX77	2030
BX78	2050
BX79	2080
BX80	2110
BX81	2130
BX82	2160
BX83	2180
BX84	2210
BX85	2240
BX86	2260
BX87	2280
BX88	2310
BX89	2330
BX90	2360
BX91	2390
BX92	2410
BX93	2440

BX SECTION	
CODE	EXTERNAL LENGTH LE (mm)
BX94	2460
BX95	2500
BX96	2510
BX97	2540
BX98	2560
BX99	2590
BX100	2620
BX103	2690
BX105	2740
BX106	2770
BX108	2820
BX112	2920
BX113	2940
BX115	2990
BX116	3020
BX120	3130
BX123	3200
BX124	3220
BX126	3270
BX128	3330
BX133	3450
BX136	3530
BX140	3630
BX144	3740
BX148	3830
BX150	3880
BX154	3990
BX158	4090
BX162	4200
BX173	4480
BX180	4650
BX191	4930

# CLASSICAL RAW EDGE

## V-BELTS | LINEA GOLD

**TABLE 4 - P<sub>b</sub> (kW) referred to Ø (mm)**

RPM / Ø	90	100	112	125	140	160	180	200	224	250	265	280
100	0,37	0,43	0,5	0,57	0,66	0,77	0,88	0,99	1,12	1,26	1,34	1,41
200	0,65	0,75	0,88	1,02	1,18	1,38	1,59	1,79	2,02	2,27	2,41	2,55
500	1,32	1,57	1,85	2,15	2,49	2,94	3,38	3,81	4,31	4,85	5,15	5,45
700	1,7	2,02	2,4	2,8	3,25	3,84	4,42	4,98	5,63	6,33	6,72	7,1
900	2,05	2,44	2,9	3,39	3,95	4,67	5,36	6,04	6,83	7,65	8,12	8,57
1.000	2,2	2,63	3,14	3,67	4,27	5,05	5,81	6,54	7,38	8,27	8,76	9,24
1.400	2,77	3,33	3,99	4,68	5,45	6,44	7,39	8,3	9,32	10,36	10,92	11,46
1.500	2,9	3,49	4,18	4,91	5,72	6,76	7,74	8,68	9,73	10,79	11,36	11,9
1.700	3,14	3,79	4,54	5,34	6,22	7,34	8,39	9,38	10,47	11,54	12,11	12,63
1.800	3,25	3,93	4,71	5,54	6,45	7,6	8,69	9,69	10,8	11,86	12,41	12,91
2.500	3,89	4,74	5,71	6,7	7,77	9,07	10,21	11,19	12,14	12,85*	13,11*	
2.900	4,16	5,08	6,12	7,17	8,28	9,56	10,63	11,45*	12,09*			
3.000	4,22	5,15	6,21	7,27	8,37	9,65	10,67	11,44*				
3.500	4,42	5,42	6,52	7,59	8,66	9,78	10,54*					
3.600	4,45	5,46	6,56	7,63	8,68	9,76*	10,44*					
4.000	4,52	5,54	6,64	7,67	8,61	9,44*						
4.500	4,49	5,51	6,56	7,47*	8,19*							
5.000	4,34	5,31*	6,26*	6,97*								

**P<sub>a</sub> (kW) referred to i**

RPM / I	1,00/1,01	1,02/1,05	1,06/1,26	1,27/1,57	OVER 1,57
100	0,00	0,00	0,02	0,03	0,04
200	0,00	0,01	0,05	0,07	0,08
500	0,00	0,02	0,12	0,17	0,20
700	0,00	0,03	0,16	0,24	0,29
900	0,00	0,03	0,21	0,30	0,37
1.000	0,00	0,04	0,23	0,34	0,41
1.400	0,00	0,05	0,33	0,47	0,57
1.500	0,00	0,06	0,35	0,51	0,61
1.700	0,00	0,06	0,40	0,57	0,69
1.800	0,00	0,07	0,42	0,61	0,73
2.500	0,00	0,09	0,59	0,84	1,02
2.900	0,00	0,11	0,68	0,98	1,18
3.000	0,00	0,11	0,70	1,01	1,22
3.500	0,00	0,13	0,82	1,18	1,43
3.600	0,00	0,13	0,85	1,21	1,47
4.000	0,00	0,15	0,94	1,35	1,63
4.500	0,00	0,17	1,06	1,52	1,84
5.000	0,00	0,18	1,17	1,69	2,04

\* Belt speed is greater than 30 m/s then is necessary to use dynamically balanced pulleys. A reduction in belt life can be expected. Suggested a smaller section.

# CLASSICAL RAW EDGE

## V-BELTS | LINEA GOLD

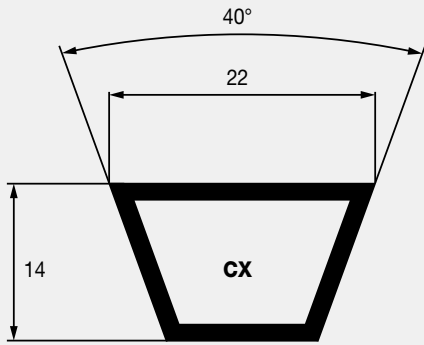

CX SECTION	
CODE	EXTERNAL LENGTH LE (mm)
CX51	1400
CX55	1500
CX60	1630
CX68	1830
CX72	1935
CX75	2000
CX78	2090
CX81	2160
CX85	2270
CX90	2390

CX SECTION	
CODE	EXTERNAL LENGTH LE (mm)
CX96	2540
CX100	2650
CX101	2670
CX105	2770
CX109	2870
CX111	2920
CX112	2950
CX115	3030
CX120	3150
CX128	3350

CX SECTION	
CODE	EXTERNAL LENGTH LE (mm)
CX136	3550
CX144	3760
CX148	3860
CX150	3920
CX158	4120
CX162	4220
CX173	4500
CX180	4680

# CLASSICAL RAW EDGE

## V-BELTS | LINEA GOLD

**TABLE 4 -  $P_b$  (kW) referred to  $\emptyset$  (mm)**

RPM / $\emptyset$	140	160	180	200	224	250	280	315	335	400	500	560
100	0,95	1,14	1,32	1,51	1,73	1,96	2,23	2,54	2,71	3,27	4,11	4,6
200	1,7	2,05	2,39	2,73	3,14	3,57	4,06	4,63	4,94	5,96	7,48	8,37
300	2,37	2,87	3,36	3,85	4,43	5,04	5,74	6,53	6,99	8,42	10,55	11,78
400	2,99	3,64	4,27	4,89	5,63	6,41	7,3	8,32	8,89	10,7	13,37	14,91
500	3,58	4,36	5,12	5,88	6,77	7,71	8,78	10	10,68	12,84	15,98	17,77
600	4,13	5,04	5,94	6,81	7,85	8,94	10,18	11,58	12,37	14,84	18,38	20,35
700	4,66	5,7	6,71	7,71	8,88	10,12	11,51	13,08	13,96	16,7	20,55	22,65
900	5,64	6,92	8,17	9,38	10,8	12,3	13,96	15,83	16,86	19,99	24,19	26,31
1.000	6,1	7,49	8,85	10,17	11,7	13,31	15,09	17,07	18,15	21,42	25,63	27,64
1.400	7,76	9,56	11,29	12,95	14,85	16,8	18,9	21,13	22,3	25,5		
1.500	8,14	10,02	11,83	13,56	15,53	17,54	19,67	21,9	23,05	26,07		
1.700	8,83	10,88	12,83	14,68	16,75	18,83	20,97	23,13	24,17			
1.800	9,15	11,27	13,28	15,18	17,29	19,38	21,5	23,57	24,54			
2.000	9,74	12	14,11	16,07	18,22	20,28	22,29	24,09				
2.500	10,92	13,4	15,63	17,61	19,62	21,31						
2.900	11,54	14,07	16,25	18,05	19,67							
3.000	11,65	14,18	16,32	18,04								
3.500	11,89	14,27	16,07									

**$P_a$  (kW) referred to  $i$**

RPM / $i$	1,00/1,01	1,02/1,05	1,06/1,26	1,27/1,57	OVER 1,57
100	0,00	0,01	0,03	0,05	0,06
200	0,00	0,01	0,07	0,10	0,12
300	0,00	0,02	0,10	0,15	0,18
400	0,00	0,02	0,14	0,20	0,24
500	0,00	0,03	0,17	0,24	0,30
600	0,00	0,03	0,20	0,29	0,36
700	0,00	0,04	0,24	0,34	0,41
900	0,00	0,05	0,31	0,44	0,53
1.000	0,00	0,05	0,34	0,49	0,59
1.400	0,00	0,07	0,48	0,68	0,83
1.500	0,00	0,08	0,51	0,73	0,89
1.700	0,00	0,09	0,58	0,83	1,01
1.800	0,00	0,10	0,61	0,88	1,07
2.000	0,00	0,11	0,68	0,98	1,18
2.500	0,00	0,13	0,85	1,22	1,48
2.900	0,00	0,15	0,99	1,42	1,72
3.000	0,00	0,16	1,02	1,47	1,78
3.500	0,00	0,19	1,19	1,71	2,07

\* Belt speed is greater than 30 m/s then is necessary to use dynamically balanced pulleys. A reduction in belt life can be expected. Suggested a smaller section.



MEGADYNE V-BELTS

# NARROW RAW EDGE V-BELTS DIN

LINEA X  
LINEA GOLD

# NARROW RAW EDGE

## V-BELTS DIN LINEA X | LINEA GOLD

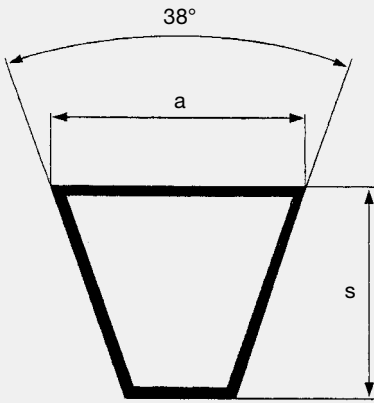

### BELT CHARACTERISTICS

SECTION	XPZ	XPA	XPB	XPC
a (mm)	9,7	12,7	16,3	22
s (mm)	8	10	13	18
External length - pitch length = Δe (mm)	13	18	22	30
Weigth (gr/m)	73	122	200	355
Min. Pulley diam. (Mm)	56	80	112	180
Working temperature	-30°C / +80°C / -40°C / +110°C			
Relevant standards	DIN 7753 - ISO 4184			
Relevant antistatic standard	ISO 1813			
Materials	EPDM compound - CR blend - polyester cord			

**TABLE 3 - CORRECTION FACTOR  $C_L$  (according to type and length of the belt)**

	512	630	710	732	800	900	1000	1120	1250	1400	1600	1800	2000	2240	2500	2800	3150	3550
XPZ	0,82	0,83	0,85	0,86	0,87	0,89	0,91	0,93	0,95	0,98	1,00	1,02	1,04	1,06	1,08	1,10	1,13	1,15
XPA				0,81	0,82	0,84	0,86	0,88	0,90	0,92	0,94	0,96	0,98	1,00	1,02	1,04	1,06	1,08
XPB									0,85	0,87	0,89	0,91	0,93	0,94	0,96	0,98	1,01	1,03
XPC													0,85	0,86	0,88	0,90	0,91	0,93

**TABLE 5 - INSTALLATION AND TAKE UP ALLOWANCE**

L (mm)	Y (mm)				X (mm)
	XPZ	XPA	XPB	XPC	
512 / 670	15	15			10
670 / 1000	15	20			14
1000 / 1250	20	20			18
1250 / 1800	20	25	30		23
1800 / 2240	25	25	30	40	28
2240 / 3000	25	30	35	45	36
3000 / 3500	30	30	40	45	44

# NARROW RAW EDGE

## V-BELTS DIN | LINEA X

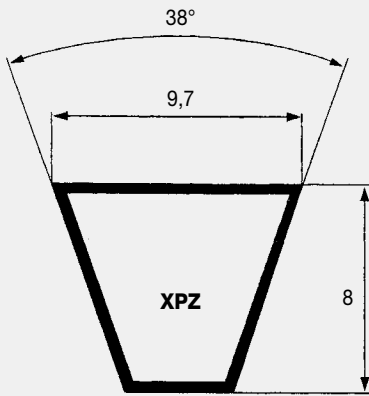

XPZ SECTION	
CODE	EXTERNAL LENGTH LE (mm)
XPZ512	525
XPZ562	575
XPZ587	600
XPZ607	620
XPZ612	625
XPZ630	643
XPZ637	650
XPZ662	675
XPZ670	683
XPZ687	700
XPZ710	723
XPZ722	735
XPZ730	743
XPZ737	750
XPZ750	763
XPZ762	775
XPZ772	785
XPZ787	800
XPZ800	813
XPZ812	825
XPZ837	850
XPZ850	863
XPZ852	865
XPZ862	875
XPZ875	888
XPZ887	900
XPZ900	913
XPZ912	925
XPZ925	938
XPZ937	950
XPZ940	953
XPZ950	963
XPZ962	975
XPZ975	988
XPZ987	1000
XPZ1000	1013
XPZ1012	1025
XPZ1021	1034
XPZ1024	1037
XPZ1030	1043

XPZ SECTION	
CODE	EXTERNAL LENGTH LE (mm)
XPZ1037	1050
XPZ1047	1060
XPZ1050	1163
XPZ1060	1073
XPZ1062	1075
XPZ1077	1090
XPZ1080	1093
XPZ1087	1100
XPZ1112	1125
XPZ1120	1133
XPZ1137	1150
XPZ1162	1175
XPZ1180	1193
XPZ1187	1200
XPZ1202	1215
XPZ1212	1225
XPZ1237	1250
XPZ1250	1263
XPZ1262	1275
XPZ1270	1283
XPZ1280	1293
XPZ1287	1300
XPZ1312	1325
XPZ1320	1333
XPZ1327	1340
XPZ1337	1350
XPZ1362	1375
XPZ1387	1400
XPZ1400	1413
XPZ1412	1425
XPZ1420	1433
XPZ1437	1450
XPZ1462	1475
XPZ1470	1483
XPZ1487	1500
XPZ1500	1513
XPZ1512	1525
XPZ1520	1533
XPZ1537	1550
XPZ1550	1563

XPZ SECTION	
CODE	EXTERNAL LENGTH LE (mm)
XPZ1562	1575
XPZ1587	1600
XPZ1600	1613
XPZ1612	1625
XPZ1637	1650
XPZ1650	1663
XPZ1662	1675
XPZ1700	1713
XPZ1737	1726
XPZ1750	1763
XPZ1762	1775
XPZ1800	1813
XPZ1812	1825
XPZ1850	1863
XPZ1862	1875
XPZ1887	1900
XPZ1900	1913
XPZ1937	1950
XPZ1950	1963
XPZ2000	2013
XPZ2030	2043
XPZ2037	2050
XPZ2120	2133
XPZ2160	2173
XPZ2240	2253
XPZ2280	2293
XPZ2360	2373
XPZ2410	2423
XPZ2500	2513
XPZ2540	2553
XPZ2650	2663
XPZ2690	2703
XPZ2800	2813
XPZ2840	2853
XPZ3000	3013
XPZ3150	3163
XPZ3170	3183
XPZ3350	3363
XPZ3550	3563

# NARROW RAW EDGE

## V-BELTS DIN | LINEA X

**TABLE 4 - P<sub>b</sub> (kW) referred to Ø (mm)**

RPM / Ø	56	60	63	67	71	80	90	100	112	125	132	140
100	0,10	0,12	0,13	0,14	0,16	0,19	0,23	0,27	0,32	0,37	0,39	0,43
200	0,19	0,22	0,24	0,27	0,30	0,37	0,44	0,52	0,61	0,70	0,75	0,81
500	0,41	0,48	0,54	0,61	0,68	0,84	1,02	1,20	1,41	1,64	1,76	1,90
700	0,55	0,65	0,72	0,82	0,92	1,14	1,39	1,63	1,92	2,23	2,40	2,58
900	0,68	0,81	0,90	1,03	1,15	1,43	1,74	2,05	2,41	2,80	3,01	3,25
1.000	0,74	0,88	0,99	1,13	1,26	1,57	1,91	2,25	2,65	3,09	3,32	3,58
1.400	0,99	1,18	1,32	1,51	1,70	2,12	2,59	3,05	3,59	4,18	4,49	4,85
1.500	1,04	1,25	1,40	1,60	1,80	2,25	2,75	3,24	3,82	4,45	4,78	5,16
1.700	1,16	1,39	1,56	1,78	2,01	2,52	3,07	3,62	4,27	4,97	5,34	5,76
1.800	1,21	1,45	1,64	1,87	2,11	2,64	3,23	3,81	4,49	5,22	5,61	6,05
2.500	1,58	1,91	2,15	2,47	2,79	3,51	4,29	5,06	5,97	6,93	7,43	8,00
2.900	1,78	2,15	2,43	2,80	3,16	3,97	4,86	5,73	6,75	7,82	8,39	9,02
3.000	1,82	2,21	2,49	2,87	3,25	4,09	5,00	5,89	6,94	8,04	8,62	9,26
3.500	2,05	2,49	2,82	3,25	3,68	4,63	5,67	6,67	7,84	9,06	9,69	10,39
3.600	2,09	2,55	2,88	3,32	3,76	4,74	5,79	6,82	8,01	9,25	9,89	10,60
4.000	2,26	2,76	3,12	3,61	4,09	5,15	6,29	7,39	8,67	9,97	10,65	
4.500	2,46	3,00	3,41	3,94	4,46	5,62	6,86	8,05	9,41	10,78	11,47*	
5.000	2,64	3,23	3,67	4,25	4,81	6,06	7,39	8,64	10,06	11,46*	12,15*	

**P<sub>a</sub> (kW) referred to i**

RPM / I	1,00/1,01	1,02/1,05	1,06/1,26	1,27/1,57	OVER 1,57
100	0,00	0,00	0,01	0,01	0,01
200	0,00	0,00	0,02	0,02	0,03
500	0,00	0,01	0,04	0,06	0,07
700	0,00	0,01	0,06	0,08	0,10
900	0,00	0,01	0,07	0,10	0,12
1.000	0,00	0,01	0,08	0,11	0,14
1.400	0,00	0,02	0,11	0,16	0,19
1.500	0,00	0,02	0,12	0,17	0,21
1.700	0,00	0,02	0,14	0,19	0,24
1.800	0,00	0,02	0,14	0,21	0,25
2.500	0,00	0,03	0,20	0,29	0,35
2.900	0,00	0,04	0,23	0,33	0,40
3.000	0,00	0,04	0,24	0,34	0,42
3.500	0,00	0,04	0,28	0,40	0,49
3.600	0,00	0,04	0,29	0,41	0,50
4.000	0,00	0,05	0,32	0,46	0,55
4.500	0,00	0,06	0,36	0,52	0,62
5.000	0,00	0,06	0,40	0,57	0,69

\* Belt speed is greater than 30 m/s then is necessary to use dynamically balanced pulleys. A reduction in belt life can be expected. Suggested a smaller section.

# NARROW RAW EDGE

## V-BELTS DIN | LINEA GOLD

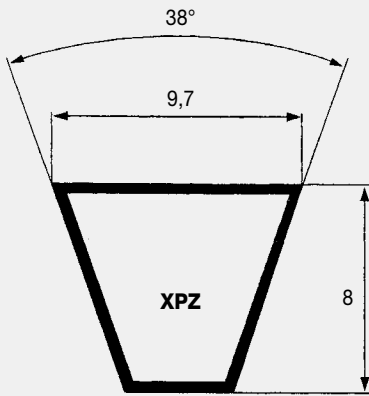

XPZ SECTION	
CODE	EXTERNAL LENGTH LE (mm)
XPZ512	525
XPZ562	575
XPZ587	600
XPZ607	620
XPZ612	625
XPZ630	643
XPZ637	650
XPZ662	675
XPZ670	683
XPZ687	700
XPZ710	723
XPZ722	735
XPZ730	743
XPZ737	750
XPZ750	763
XPZ762	775
XPZ772	785
XPZ787	800
XPZ800	813
XPZ812	825
XPZ837	850
XPZ850	863
XPZ852	865
XPZ862	875
XPZ875	888
XPZ887	900
XPZ900	913
XPZ912	925
XPZ925	938
XPZ937	950
XPZ940	953
XPZ950	963
XPZ962	975
XPZ975	988
XPZ1000	1013
XPZ1012	1025
XPZ1021	1034
XPZ1024	1037
XPZ1030	1043
XPZ1037	1050

XPZ SECTION	
CODE	EXTERNAL LENGTH LE (mm)
XPZ1047	1060
XPZ1060	1073
XPZ1062	1075
XPZ1077	1090
XPZ1080	1093
XPZ1087	1100
XPZ1112	1125
XPZ1120	1133
XPZ1137	1150
XPZ1150	1150
XPZ1162	1175
XPZ1180	1193
XPZ1187	1200
XPZ1202	1215
XPZ1212	1225
XPZ1237	1250
XPZ1250	1263
XPZ1262	1275
XPZ1270	1283
XPZ1280	1293
XPZ1287	1300
XPZ1312	1325
XPZ1320	1333
XPZ1327	1340
XPZ1337	1350
XPZ1362	1375
XPZ1387	1400
XPZ1400	1413
XPZ1412	1425
XPZ1420	1433
XPZ1437	1450
XPZ1462	1475
XPZ1470	1483
XPZ1487	1500
XPZ1500	1513
XPZ1512	1525
XPZ1520	1533
XPZ1537	1550
XPZ1550	1563
XPZ1562	1575

XPZ SECTION	
CODE	EXTERNAL LENGTH LE (mm)
XPZ1587	1600
XPZ1600	1613
XPZ1612	1625
XPZ1637	1650
XPZ1650	1663
XPZ1662	1675
XPZ1700	1713
XPZ1737	1726
XPZ1750	1763
XPZ1762	1775
XPZ1800	1813
XPZ1812	1825
XPZ1850	1863
XPZ1862	1875
XPZ1887	1900
XPZ1900	1913
XPZ1937	1950
XPZ1950	1963
XPZ2000	2013
XPZ2030	2043
XPZ2037	2050
XPZ2120	2133
XPZ2160	2173
XPZ2240	2253
XPZ2280	2293
XPZ2360	2373
XPZ2410	2423
XPZ2500	2513
XPZ2540	2553
XPZ2650	2663
XPZ2690	2703
XPZ2800	2813
XPZ2840	2853
XPZ3000	3013
XPZ3150	3163
XPZ3170	3183
XPZ3350	3363
XPZ3550	3563

# NARROW RAW EDGE

## V-BELTS DIN | LINEA GOLD

**TABLE 4 -  $P_b$  (kW) referred to  $\emptyset$  (mm)**

RPM / $\emptyset$	56	60	63	67	71	80	90	100	112	125	132	140
100	0,13	0,16	0,17	0,19	0,21	0,26	0,32	0,37	0,43	0,50	0,54	0,58
200	0,25	0,29	0,32	0,37	0,41	0,50	0,61	0,71	0,83	0,97	1,04	1,12
500	0,57	0,67	0,74	0,85	0,95	1,17	1,42	1,67	1,96	2,28	2,45	2,65
700	0,77	0,90	1,01	1,15	1,29	1,60	1,94	2,28	2,69	3,12	3,36	3,63
900	0,95	1,13	1,26	1,44	1,62	2,01	2,45	2,88	3,39	3,94	4,24	4,58
1.000	1,05	1,24	1,39	1,58	1,78	2,21	2,69	3,17	3,74	4,35	4,67	5,04
1.400	1,40	1,67	1,87	2,14	2,41	3,00	3,66	4,31	5,08	5,91	6,35	6,85
1.500	1,49	1,78	1,99	2,28	2,56	3,20	3,90	4,59	5,41	6,29	6,76	7,29
1.700	1,66	1,98	2,22	2,54	2,86	3,58	4,36	5,14	6,05	7,04	7,56	8,15
1.800	1,74	2,08	2,34	2,68	3,01	3,76	4,59	5,40	6,37	7,40	7,95	8,57
2.500	2,30	2,76	3,10	3,56	4,01	5,02	6,12	7,20	8,46	9,80	10,50	11,29
2.900	2,59	3,12	3,51	4,03	4,54	5,69	6,93	8,15	9,56	11,04	11,82	12,68
3.000	2,66	3,20	3,61	4,14	4,67	5,85	7,13	8,38	9,83	11,34	12,12	13,00
3.500	3,00	3,63	4,09	4,70	5,30	6,63	8,07	9,46	11,06	12,70	13,55	14,47
3.600	3,07	3,71	4,18	4,80	5,42	6,78	8,25	9,66	11,29	12,95	13,80	14,73
4.000	3,32	4,02	4,53	5,21	5,88	7,35	8,93	10,44	12,15	13,87	14,74	15,68
4.500	3,62	4,38	4,94	5,69	6,42	8,01	9,71	11,30	13,08	14,83	15,68*	16,58*
5.000	3,88	4,71	5,32	6,12	6,90	8,61	10,39	12,04	13,84	15,55*	16,35*	

**$P_d$  (kW) referred to  $i$**

RPM / $i$	1,00/1,01	1,02/1,05	1,06/1,26	1,27/1,57	OVER 1,57
100	0,00	0,00	0,01	0,01	0,01
200	0,00	0,00	0,02	0,02	0,03
500	0,00	0,01	0,04	0,06	0,07
700	0,00	0,01	0,06	0,08	0,10
900	0,00	0,01	0,07	0,10	0,12
1.000	0,00	0,01	0,08	0,11	0,14
1.400	0,00	0,02	0,11	0,16	0,19
1.500	0,00	0,02	0,12	0,17	0,21
1.700	0,00	0,02	0,14	0,20	0,24
1.800	0,00	0,02	0,14	0,21	0,25
2.500	0,00	0,03	0,20	0,29	0,35
2.900	0,00	0,04	0,23	0,33	0,40
3.000	0,00	0,04	0,24	0,34	0,42
3.500	0,00	0,04	0,28	0,40	0,49
3.600	0,00	0,04	0,29	0,41	0,50
4.000	0,00	0,05	0,32	0,46	0,56
4.500	0,00	0,06	0,36	0,52	0,62
5.000	0,00	0,06	0,40	0,57	0,69

\* Belt speed is greater than 30 m/s then is necessary to use dynamically balanced pulleys. A reduction in belt life can be expected. Suggested a smaller section.

# NARROW RAW EDGE

## V-BELTS DIN | LINEA X

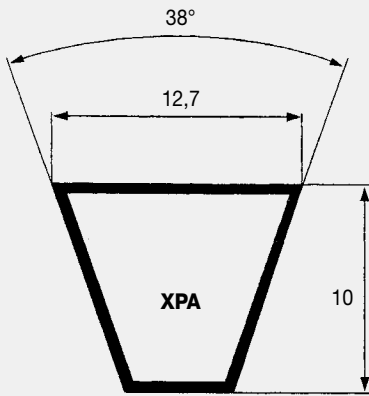

XPA SECTION	
CODE	EXTERNAL LENGTH LE (mm)
XPA667	685
XPA682	700
XPA732	750
XPA757	775
XPA765	783
XPA782	800
XPA800	818
XPA807	825
XPA832	850
XPA850	868
XPA857	875
XPA882	900
XPA900	918
XPA907	925
XPA925	943
XPA932	950
XPA950	968
XPA957	975
XPA965	983
XPA969	987
XPA982	1000
XPA1000	1018
XPA1007	1025
XPA1032	1050
XPA1057	1075
XPA1060	1078
XPA1082	1100
XPA1107	1125
XPA1120	1138
XPA1132	1150
XPA1140	1158
XPA1150	1168
XPA1157	1175
XPA1162	1180
XPA1180	1198
XPA1182	1200
XPA1207	1225
XPA1215	1233

XPA SECTION	
CODE	EXTERNAL LENGTH LE (mm)
XPA1232	1250
XPA1250	1268
XPA1257	1275
XPA1272	1290
XPA1282	1300
XPA1307	1325
XPA1320	1338
XPA1332	1350
XPA1357	1375
XPA1367	1385
XPA1382	1400
XPA1400	1418
XPA1407	1425
XPA1420	1438
XPA1432	1450
XPA1450	1468
XPA1457	1475
XPA1482	1500
XPA1500	1518
XPA1507	1525
XPA1532	1550
XPA1557	1575
XPA1582	1600
XPA1600	1618
XPA1607	1625
XPA1632	1650
XPA1650	1668
XPA1657	1675
XPA1682	1700
XPA1700	1718
XPA1732	1750
XPA1750	1768
XPA1757	1775
XPA1782	1800
XPA1800	1818
XPA1832	1850
XPA1850	1868
XPA1882	1900

XPA SECTION	
CODE	EXTERNAL LENGTH LE (mm)
XPA1900	1918
XPA1932	1950
XPA1950	1968
XPA1957	1975
XPA1982	2000
XPA2000	2018
XPA2032	2050
XPA2057	2075
XPA2082	2100
XPA2120	2138
XPA2160	2178
XPA2182	2200
XPA2240	2258
XPA2282	2300
XPA2300	2318
XPA2360	2378
XPA2432	2450
XPA2482	2500
XPA2500	2518
XPA2532	2550
XPA2582	2600
XPA2607	2625
XPA2632	2650
XPA2650	2668
XPA2682	2700
XPA2732	2750
XPA2782	2800
XPA2800	2818
XPA3000	3018
XPA3150	3168
XPA3350	3368
XPA3550	3568
XPA3750	3768
XPA4000	4018
XPA4250	4268
XPA4500	4518

# NARROW RAW EDGE

## V-BELTS DIN | LINEA X

**TABLE 4 -  $P_b$  (kW) referred to  $\emptyset$  (mm)**

RPM / $\emptyset$	80	85	90	95	100	106	112	125	140	160	180	200
100	0,25	0,28	0,31	0,34	0,37	0,41	0,45	0,53	0,63	0,75	0,87	1,00
200	0,45	0,51	0,58	0,64	0,70	0,77	0,85	1,00	1,18	1,42	1,66	1,90
500	1,00	1,15	1,29	1,44	1,58	1,76	1,93	2,30	2,73	3,29	3,85	4,40
700	1,33	1,53	1,73	1,93	2,13	2,37	2,60	3,11	3,69	4,46	5,23	5,98
900	1,65	1,90	2,15	2,40	2,65	2,95	3,25	3,89	4,63	5,60	6,55	7,50
1.000	1,80	2,08	2,35	2,63	2,91	3,24	3,57	4,28	5,08	6,15	7,20	8,24
1.400	2,37	2,76	3,13	3,51	3,89	4,34	4,79	5,75	6,84	8,28	9,70	11,09
1.500	2,51	2,92	3,32	3,72	4,13	4,60	5,08	6,10	7,27	8,80	10,30	11,78
1.700	2,78	3,23	3,69	4,14	4,59	5,12	5,66	6,80	8,10	9,80	11,47	13,11
1.800	2,91	3,39	3,87	4,34	4,82	5,38	5,94	7,14	8,51	10,29	12,04	13,75
2.500	3,77	4,41	5,05	5,69	6,32	7,07	7,81	9,40	11,19	13,51	15,74	17,89
2.900	4,21	4,95	5,67	6,39	7,11	7,96	8,80	10,58	12,59	15,16	17,61	19,93*
3.000	4,32	5,07	5,82	6,56	7,30	8,17	9,03	10,87	12,92	15,55	18,04	20,40*
3.500	4,82	5,68	6,53	7,37	8,20	9,19	10,16	12,21	14,48	17,35	20,02*	
3.600	4,92	5,80	6,67	7,53	8,38	9,38	10,37	12,46	14,77	17,68*	20,37*	
4.000	5,28	6,24	7,18	8,11	9,03	10,11	11,18	13,41	15,86	18,89*		
4.500	5,69	6,73	7,76	8,78	9,77	10,94	12,09	14,46	17,03*			
5.000	6,04	7,17	8,28	9,36	10,42	11,67	12,87	15,36*				

**$P_d$  (kW) referred to  $i$**

RPM / $i$	1,00/1,01	1,02/1,05	1,06/1,26	1,27/1,57	OVER 1,57
100	0,00	0,00	0,02	0,03	0,03
200	0,00	0,01	0,04	0,05	0,06
500	0,00	0,01	0,09	0,13	0,16
700	0,00	0,02	0,13	0,18	0,22
900	0,00	0,03	0,16	0,23	0,28
1.000	0,00	0,03	0,18	0,26	0,31
1.400	0,00	0,04	0,25	0,36	0,44
1.500	0,00	0,04	0,27	0,39	0,47
1.700	0,00	0,05	0,30	0,44	0,53
1.800	0,00	0,05	0,32	0,46	0,56
2.500	0,00	0,07	0,45	0,64	0,78
2.900	0,00	0,08	0,52	0,75	0,90
3.000	0,00	0,08	0,54	0,77	0,93
3.500	0,00	0,10	0,63	0,90	1,09
3.600	0,00	0,10	0,64	0,93	1,12
4.000	0,00	0,11	0,72	1,03	1,24
4.500	0,00	0,13	0,81	1,16	1,40
5.000	0,00	0,14	0,90	1,29	1,56

\* Belt speed is greater than 30 m/s then is necessary to use dynamically balanced pulleys. A reduction in belt life can be expected. Suggested a smaller section.

# NARROW RAW EDGE

## V-BELTS DIN | LINEA GOLD

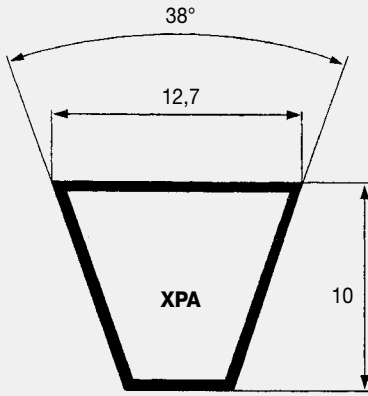

XPA SECTION	
CODE	EXTERNAL LENGTH LE (mm)
XPA667	685
XPA682	700
XPA732	750
XPA757	775
XPA765	783
XPA782	800
XPA800	818
XPA807	825
XPA832	850
XPA850	868
XPA857	875
XPA882	900
XPA900	918
XPA907	925
XPA925	943
XPA932	950
XPA950	968
XPA957	975
XPA965	983
XPA969	987
XPA982	1000
XPA1000	1018
XPA1007	1025
XPA1032	1050
XPA1057	1075
XPA1060	1078
XPA1082	1100
XPA1107	1125
XPA1120	1138
XPA1132	1150
XPA1140	1158
XPA1150	1168
XPA1157	1175
XPA1162	1180
XPA1180	1198
XPA1182	1200
XPA1207	1225
XPA1215	1233

XPA SECTION	
CODE	EXTERNAL LENGTH LE (mm)
XPA1232	1250
XPA1250	1268
XPA1257	1275
XPA1272	1290
XPA1282	1300
XPA1307	1325
XPA1320	1338
XPA1332	1350
XPA1357	1375
XPA1367	1385
XPA1382	1400
XPA1400	1418
XPA1407	1425
XPA1420	1438
XPA1432	1450
XPA1450	1468
XPA1457	1475
XPA1482	1500
XPA1500	1518
XPA1507	1525
XPA1532	1550
XPA1557	1575
XPA1582	1600
XPA1600	1618
XPA1607	1625
XPA1632	1650
XPA1650	1668
XPA1657	1675
XPA1682	1700
XPA1700	1718
XPA1732	1750
XPA1750	1768
XPA1757	1775
XPA1782	1800
XPA1800	1818
XPA1832	1850
XPA1850	1868
XPA1882	1900

XPA SECTION	
CODE	EXTERNAL LENGTH LE (mm)
XPA1900	1918
XPA1932	1950
XPA1950	1968
XPA1957	1975
XPA1982	2000
XPA2000	2018
XPA2032	2050
XPA2057	2075
XPA2082	2100
XPA2120	2138
XPA2160	2178
XPA2182	2200
XPA2240	2258
XPA2282	2300
XPA2300	2318
XPA2360	2378
XPA2432	2450
XPA2482	2500
XPA2500	2518
XPA2532	2550
XPA2582	2600
XPA2607	2625
XPA2632	2650
XPA2650	2668
XPA2682	2700
XPA2732	2750
XPA2782	2800
XPA2800	2818
XPA3000	3018
XPA3150	3168
XPA3350	3368
XPA3550	3568
XPA3750	3768
XPA4000	4018
XPA4250	4268
XPA4500	4518

# NARROW RAW EDGE

## V-BELTS DIN | LINEA GOLD

**TABLE 4 - P<sub>b</sub> (kW) referred to Ø (mm)**

RPM / Ø	80	85	90	95	100	106	112	125	140	160	180	200
100	0,31	0,35	0,39	0,43	0,47	0,52	0,57	0,67	0,80	0,96	1,11	1,27
200	0,57	0,65	0,73	0,81	0,89	0,99	1,08	1,28	1,52	1,83	2,14	2,44
500	1,30	1,49	1,68	1,87	2,06	2,29	2,51	3,00	3,56	4,30	5,03	5,76
700	1,75	2,01	2,27	2,54	2,80	3,11	3,42	4,08	4,85	5,86	6,87	7,86
900	2,18	2,51	2,85	3,18	3,51	3,90	4,29	5,14	6,10	7,38	8,65	9,90
1.000	2,39	2,76	3,13	3,49	3,85	4,29	4,72	5,65	6,72	8,13	9,52	10,89
1.400	3,20	3,70	4,20	4,70	5,20	5,79	6,38	7,65	9,09	10,99	12,86	14,69
1.500	3,39	3,93	4,46	4,99	5,52	6,15	6,78	8,13	9,67	11,68	13,66	15,60
1.700	3,77	4,37	4,97	5,57	6,16	6,87	7,57	9,08	10,79	13,03	15,22	17,36
1.800	3,96	4,59	5,22	5,85	6,47	7,21	7,95	9,54	11,34	13,69	15,98	18,20
2.500	5,18	6,03	6,87	7,71	8,54	9,53	10,51	12,59	14,93	17,93	20,80	23,51
2.900	5,82	6,79	7,74	8,69	9,63	10,74	11,84	14,17	16,76	20,05	23,13	25,99*
3.000	5,97	6,97	7,95	8,93	9,89	11,03	12,16	14,54	17,19	20,54	23,66	26,53*
3.500	6,70	7,83	8,94	10,04	11,12	12,40	13,65	16,29	19,17	22,74	25,96*	
3.600	6,83	7,99	9,12	10,25	11,35	12,65	13,93	16,61	19,53	23,13*	26,35*	
4.000	7,35	8,60	9,83	11,03	12,22	13,61	14,97	17,80	20,84	24,49*		
4.500	7,92	9,28	10,61	11,91	13,18	14,67	16,11	19,06	22,15*			
5.000	8,41	9,86	11,28	12,66	13,99	15,54	17,03	20,03*				

**P<sub>a</sub> (kW) referred to i**

RPM / I	1,00/1,01	1,02/1,05	1,06/1,26	1,27/1,57	OVER 1,57
100	0,00	0,00	0,02	0,03	0,03
200	0,00	0,01	0,04	0,05	0,06
500	0,00	0,01	0,09	0,13	0,16
700	0,00	0,02	0,13	0,18	0,22
900	0,00	0,03	0,16	0,23	0,28
1.000	0,00	0,03	0,18	0,26	0,31
1.400	0,00	0,04	0,25	0,36	0,44
1.500	0,00	0,04	0,27	0,39	0,47
1.700	0,00	0,05	0,30	0,44	0,53
1.800	0,00	0,05	0,32	0,46	0,56
2.500	0,00	0,07	0,45	0,64	0,78
2.900	0,00	0,08	0,52	0,75	0,90
3.000	0,00	0,08	0,54	0,77	0,93
3.500	0,00	0,10	0,63	0,90	1,09
3.600	0,00	0,10	0,64	0,93	1,12
4.000	0,00	0,11	0,72	1,03	1,24
4.500	0,00	0,13	0,81	1,16	1,40
5.000	0,00	0,14	0,90	1,29	1,56

\* Belt speed is greater than 30 m/s then is necessary to use dynamically balanced pulleys. A reduction in belt life can be expected. Suggested a smaller section.

# NARROW RAW EDGE

## V-BELTS DIN | LINEA X

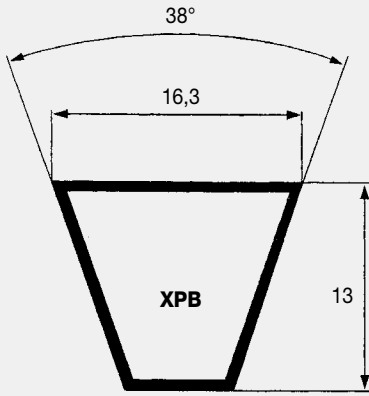

XPB SECTION	
CODE	EXTERNAL LENGTH LE (mm)
XPB1250	1272
XPB1260	1282
XPB1320	1342
XPB1340	1362
XPB1400	1422
XPB1410	1432
XPB1450	1472
XPB1500	1522
XPB1510	1532
XPB1550	1572
XPB1590	1612
XPB1600	1622
XPB1650	1672
XPB1690	1712
XPB1700	1722
XPB1710	1732
XPB1750	1772
XPB1800	1822
XPB1850	1872
XPB1900	1922

XPB SECTION	
CODE	EXTERNAL LENGTH LE (mm)
XPB1950	1972
XPB1970	1982
XPB2000	2022
XPB2020	2042
XPB2060	2082
XPB2120	2142
XPB2150	2172
XPB2180	2202
XPB2240	2262
XPB2280	2302
XPB2300	2322
XPB2360	2382
XPB2410	2432
XPB2430	2452
XPB2500	2522
XPB2530	2552
XPB2580	2602
XPB2650	2672
XPB2680	2702
XPB2800	2822

XPB SECTION	
CODE	EXTERNAL LENGTH LE (mm)
XPB2840	2862
XPB2900	2922
XPB2990	3012
XPB3000	3022
XPB3070	3092
XPB3150	3172
XPB3170	3192
XPB3340	3362
XPB3350	3372
XPB3550	3572
XPB3750	3772
XPB3800	3822
XPB4000	4022
XPB4060	4082
XPB4250	4272
XPB4500	4522
XPB4560	4582
XPB4750	4772
XPB5000	5022

# NARROW RAW EDGE

## V-BELTS DIN | LINEA X

**TABLE 4 - P<sub>b</sub> (kW) referred to Ø (mm)**

RPM / Ø	112	118	125	132	140	160	180	200	224	250	265	280
100	0,57	0,63	0,70	0,77	0,85	1,06	1,26	1,46	1,70	1,95	2,10	2,25
200	1,04	1,16	1,30	1,44	1,60	1,99	2,37	2,76	3,22	3,71	3,99	4,27
500	2,32	2,60	2,93	3,25	3,63	4,55	5,46	6,37	7,44	8,60	9,27	9,93
700	3,10	3,48	3,93	4,38	4,88	6,14	7,39	8,63	10,09	11,67	12,57	13,47
900	3,84	4,32	4,89	5,45	6,09	7,68	9,24	10,80	12,64	14,61	15,74	16,85
1.000	4,19	4,73	5,35	5,97	6,67	8,42	10,15	11,85	13,88	16,04	17,27	18,49
1.400	5,54	6,27	7,12	7,96	8,91	11,28	13,60	15,89	18,59	21,45	23,07	24,66
1.500	5,86	6,64	7,54	8,43	9,45	11,96	14,43	16,85	19,70	22,72	24,42	26,10
1.700	6,48	7,35	8,36	9,36	10,49	13,29	16,03	18,72	21,86	25,17	27,03	28,85
1.800	6,79	7,70	8,76	9,81	11,00	13,93	16,81	19,62	22,90	26,34	28,27	30,16
2.500	8,73	9,94	11,34	12,73	14,29	18,11	21,79	25,33	29,37	33,48*	35,72*	
2.900	9,71	11,08	12,65	14,21	15,95	20,19	24,23	28,06*	32,36*			
3.000	9,94	11,35	12,96	14,55	16,34	20,68	24,79	28,68*				
3.500	11,00	12,57	14,37	16,14	18,12	22,86	27,28*					
3.600	11,19	12,79	14,63	16,43	18,45	23,25*	27,71*					
4.000	11,88	13,60	15,57	17,48	19,61	24,63*						
4.500	12,59	14,43	16,52	18,54*	20,77*							
5.000	13,10	15,04*	17,22*	19,31*								

**P<sub>a</sub> (kW) referred to i**

RPM / i	1,00/1,01	1,02/1,05	1,06/1,26	1,27/1,57	OVER 1,57
100	0,00	0,01	0,04	0,06	0,07
200	0,00	0,01	0,08	0,11	0,14
500	0,00	0,03	0,20	0,28	0,34
700	0,00	0,04	0,27	0,39	0,47
900	0,00	0,05	0,35	0,50	0,61
1.000	0,00	0,06	0,39	0,56	0,68
1.400	0,00	0,09	0,55	0,78	0,95
1.500	0,00	0,09	0,59	0,84	1,02
1.700	0,00	0,10	0,66	0,95	1,15
1.800	0,00	0,11	0,70	1,01	1,22
2.500	0,00	0,15	0,98	1,40	1,69
2.900	0,00	0,18	1,13	1,62	1,97
3.000	0,00	0,18	1,17	1,68	2,03
3.500	0,00	0,21	1,37	1,96	2,37
3.600	0,00	0,22	1,40	2,02	2,44
4.000	0,00	0,24	1,56	2,24	2,71
4.500	0,00	0,27	1,76	2,52	3,05
5.000	0,00	0,31	1,95	2,80	3,39

\* Belt speed is greater than 30 m/s then is necessary to use dynamically balanced pulleys. A reduction in belt life can be expected. Suggested a smaller section.

# NARROW RAW EDGE

## V-BELTS DIN | LINEA GOLD

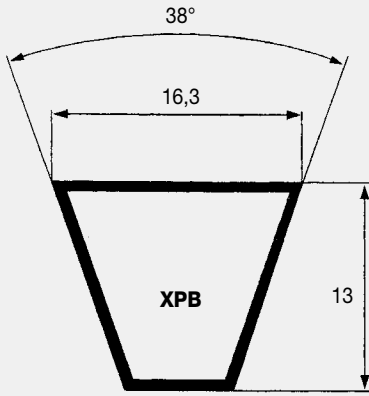

XPB SECTION	
CODE	EXTERNAL LENGTH LE (mm)
XPB1250	1272
XPB1260	1282
XPB1320	1342
XPB1340	1362
XPB1400	1422
XPB1410	1432
XPB1450	1472
XPB1500	1522
XPB1510	1532
XPB1550	1572
XPB1590	1612
XPB1600	1622
XPB1650	1672
XPB1690	1712
XPB1700	1722
XPB1710	1732
XPB1750	1772
XPB1800	1822
XPB1850	1872
XPB1900	1922

XPB SECTION	
CODE	EXTERNAL LENGTH LE (mm)
XPB1950	1972
XPB1970	1982
XPB2000	2022
XPB2020	2042
XPB2060	2082
XPB2120	2142
XPB2150	2172
XPB2180	2202
XPB2240	2262
XPB2280	2302
XPB2300	2322
XPB2360	2382
XPB2410	2432
XPB2430	2452
XPB2500	2522
XPB2530	2552
XPB2580	2602
XPB2650	2672
XPB2680	2702
XPB2800	2822

XPB SECTION	
CODE	EXTERNAL LENGTH LE (mm)
XPB2840	2862
XPB2900	2922
XPB2990	3012
XPB3000	3022
XPB3070	3092
XPB3150	3172
XPB3170	3192
XPB3340	3362
XPB3350	3372
XPB3550	3572
XPB3750	3772
XPB3800	3822
XPB4000	4022
XPB4060	4082
XPB4250	4272
XPB4500	4522
XPB4560	4582
XPB4750	4772
XPB5000	5022

# NARROW RAW EDGE

## V-BELTS DIN | LINEA GOLD

**TABLE 4 - P<sub>b</sub> (kW) referred to Ø (mm)**

RPM / Ø	112	118	125	132	140	160	180	200	224	250	265	280
100	0,73	0,81	0,90	0,99	1,10	1,37	1,63	1,89	2,21	2,54	2,74	2,93
200	1,36	1,52	1,70	1,88	2,09	2,60	3,11	3,62	4,23	4,88	5,26	5,63
500	3,10	3,47	3,91	4,34	4,83	6,06	7,29	8,50	9,95	11,50	12,40	13,29
700	4,18	4,69	5,29	5,89	6,57	8,26	9,93	11,60	13,58	15,70	16,92	18,14
900	5,21	5,87	6,62	7,38	8,24	10,38	12,49	14,59	17,09	19,76	21,29	22,81
1.000	5,72	6,44	7,28	8,11	9,06	11,41	13,75	16,06	18,80	21,74	23,41	25,07
1.400	7,66	8,64	9,78	10,92	12,21	15,42	18,58	21,69	25,37	29,27	31,49	33,67
1.500	8,12	9,17	10,39	11,60	12,98	16,38	19,74	23,04	26,94	31,06	33,40	35,70
1.700	9,03	10,21	11,57	12,93	14,47	18,27	22,00	25,67	29,97	34,51	37,07	39,57
1.800	9,48	10,71	12,15	13,57	15,19	19,19	23,11	26,95	31,44	36,17	38,82	41,42
2.500	12,39	14,04	15,94	17,83	19,97	25,20	30,25	35,12	40,70	46,40*	49,51*	
2.900	13,89	15,76	17,91	20,03	22,43	28,25	33,82	39,11*	45,08*			
3.000	14,25	16,16	18,37	20,55	23,01	28,97	34,65	40,03*				
3.500	15,91	18,07	20,55	22,98	25,70	32,25	38,37*					
3.600	16,22	18,42	20,95	23,42	26,20	32,84*	39,02*					
4.000	17,36	19,73	22,43	25,08	28,02	34,98*						
4.500	18,59	21,13	24,01	26,82	29,91*							
5.000	19,56	22,24*	25,26*	28,17*								

**P<sub>a</sub> (kW) referred to i**

RPM / i	1,00/1,01	1,02/1,05	1,06/1,26	1,27/1,57	OVER 1,57
100	0,00	0,01	0,04	0,06	0,07
200	0,00	0,01	0,08	0,11	0,14
500	0,00	0,03	0,20	0,28	0,34
700	0,00	0,04	0,27	0,39	0,47
900	0,00	0,05	0,35	0,50	0,61
1.000	0,00	0,06	0,39	0,56	0,68
1.400	0,00	0,09	0,55	0,78	0,95
1.500	0,00	0,09	0,59	0,84	1,02
1.700	0,00	0,10	0,66	0,95	1,15
1.800	0,00	0,11	0,70	1,01	1,22
2.500	0,00	0,15	0,98	1,40	1,69
2.900	0,00	0,18	1,13	1,62	1,97
3.000	0,00	0,18	1,17	1,68	2,03
3.500	0,00	0,21	1,37	1,96	2,37
3.600	0,00	0,22	1,40	2,02	2,44
4.000	0,00	0,24	1,56	2,24	2,71
4.500	0,00	0,27	1,76	2,52	3,05
5.000	0,00	0,31	1,95	2,80	3,39

\* Belt speed is greater than 30 m/s then is necessary to use dynamically balanced pulleys. A reduction in belt life can be expected. Suggested a smaller section.

# NARROW RAW EDGE

## V-BELTS DIN | LINEA X

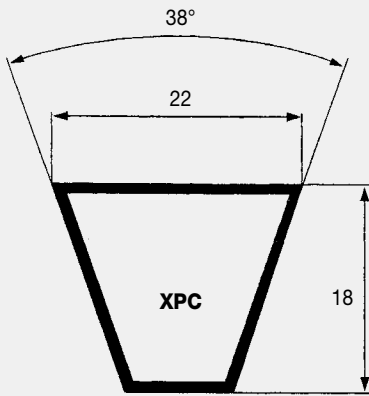

XPC SECTION	
CODE	EXTERNAL LENGTH LE (mm)
XPC2000	2030
XPC2120	2150
XPC2240	2270
XPC2360	2390
XPC2500	2530
XPC2650	2680

XPC SECTION	
CODE	EXTERNAL LENGTH LE (mm)
XPC2800	2830
XPC3000	3030
XPC3150	3180
XPC3350	3380
XPC3550	3580
XPC3750	3780

XPC SECTION	
CODE	EXTERNAL LENGTH LE (mm)
XPC4000	4030
XPC4250	4280
XPC4500	4530
XPC4750	4780
XPC5000	5030

# NARROW RAW EDGE

## V-BELTS DIN | LINEA X

**TABLE 4 - P<sub>b</sub> (kW) referred to Ø (mm)**

RPM / Ø	180	200	224	250	280	315	335	400	500	560	630	710
100	1,47	1,76	2,10	2,47	2,90	3,40	3,68	4,60	6,01	6,86	7,83	8,95
200	2,86	3,43	4,10	4,84	5,68	6,66	7,22	9,02	11,79	13,43	15,35	17,52
300	4,22	5,06	6,07	7,15	8,40	9,85	10,68	13,35	17,43	19,85	22,66	25,83
400	5,56	6,67	8,00	9,43	11,08	12,99	14,08	17,60	22,94	26,10	29,74	33,84
500	6,88	8,25	9,90	11,68	13,72	16,08	17,43	21,76	28,31	32,16	36,57	41,50
600	8,18	9,82	11,78	13,90	16,32	19,12	20,72	25,83	33,51	38,00	43,10	48,75
700	9,46	11,36	13,64	16,08	18,88	22,11	23,94	29,80	38,54	43,59	49,29	55,51
900	11,98	14,39	17,26	20,34	23,85	27,89	30,17	37,40	47,96	53,91	60,45	67,32
1.000	13,22	15,87	19,03	22,42	26,27	30,68	33,17	41,01	52,30	58,57	65,32	
1.400	17,97	21,56	25,80	30,30	35,35	41,05	44,20	53,86				
1.500	19,11	22,92	27,40	32,15	37,46	43,41	46,69	56,62				
1.700	21,32	25,54	30,49	35,68	41,44	47,82	51,28					
1.800	22,39	26,81	31,97	37,36	43,32	49,85	53,37					
2.000	24,45	29,23	34,78	40,53	46,80	53,55						
2.500	29,12	34,65	40,91	47,20								
2.900	32,28	38,19	44,73									
3.000	32,98	38,96										
3.500	35,89											

**P<sub>a</sub> (kW) referred to i**

RPM / i	1,00/1,01	1,02/1,05	1,06/1,26	1,27/1,57	OVER 1,57
100	0,00	0,01	0,07	0,10	0,12
200	0,00	0,02	0,14	0,20	0,25
300	0,00	0,03	0,21	0,30	0,37
400	0,00	0,04	0,28	0,41	0,49
500	0,00	0,06	0,35	0,51	0,61
600	0,00	0,07	0,42	0,61	0,74
700	0,00	0,08	0,49	0,71	0,86
900	0,00	0,10	0,64	0,91	1,10
1.000	0,00	0,11	0,71	1,01	1,23
1.400	0,00	0,15	0,99	1,42	1,72
1.500	0,00	0,17	1,06	1,52	1,84
1.700	0,00	0,19	1,20	1,72	2,08
1.800	0,00	0,20	1,27	1,82	2,21
2.000	0,00	0,22	1,41	2,03	2,45
2.500	0,00	0,28	1,76	2,53	3,07
2.900	0,00	0,32	2,05	2,94	3,56
3.000	0,00	0,33	2,12	3,04	3,68
3.500	0,00	0,39	2,47	3,55	4,29

\* Belt speed is greater than 30 m/s then is necessary to use dynamically balanced pulleys. A reduction in belt life can be expected. Suggested a smaller section.

# NARROW RAW EDGE

## V-BELTS DIN | LINEA GOLD

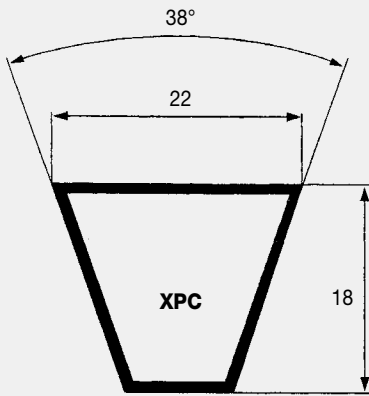

XPC SECTION	
CODE	EXTERNAL LENGTH LE (mm)
XPC2000	2030
XPC2120	2150
XPC2240	2270
XPC2360	2390
XPC2500	2530
XPC2650	2680

XPC SECTION	
CODE	EXTERNAL LENGTH LE (mm)
XPC2800	2830
XPC3000	3030
XPC3150	3180
XPC3350	3380
XPC3550	3580
XPC3750	3780

XPC SECTION	
CODE	EXTERNAL LENGTH LE (mm)
XPC4000	4030
XPC4250	4280
XPC4500	4530
XPC4750	4780
XPC5000	5030

# NARROW RAW EDGE

## V-BELTS DIN | LINEA GOLD

**TABLE 4 -  $P_b$  (kW) referred to  $\emptyset$  (mm)**

RPM / $\emptyset$	180	200	224	250	280	315	335	400	500	560	630	710
100	1,84	2,26	2,76	3,31	3,93	4,66	5,08	6,43	8,50	9,74	11,18	12,82
200	3,60	4,43	5,42	6,50	7,74	9,18	10,00	12,66	16,73	19,16	21,98	25,19
300	5,32	6,56	8,04	9,64	11,48	13,62	14,83	18,78	24,78	28,35	32,48	37,15
400	7,02	8,66	10,62	12,73	15,16	17,98	19,59	24,77	32,63	37,26	42,60	48,59
500	8,70	10,73	13,16	15,78	18,79	22,27	24,25	30,62	40,22	45,84	52,26	59,38
600	10,35	12,77	15,66	18,78	22,35	26,48	28,82	36,32	47,53	54,02	61,36	69,38
700	11,98	14,78	18,13	21,73	25,84	30,59	33,27	41,84	54,50	61,74	69,80	78,46
900	15,16	18,71	22,93	27,45	32,59	38,49	41,80	52,24	67,23	75,49	84,34	93,27
1.000	16,71	20,62	25,26	30,21	35,84	42,25	45,84	57,08	72,90	81,40	90,22	
1.400	22,59	27,83	33,99	40,49	47,73	55,79	60,20	73,39				
1.500	23,97	29,51	36,01	42,83	50,39	58,74	63,26	76,58				
1.700	26,61	32,72	39,82	47,20	55,27	64,02	68,66					
1.800	27,86	34,23	41,60	49,22	57,48	66,32	70,95					
2.000	30,23	37,06	44,90	52,89	61,38	70,21						
2.500	35,21	42,88	51,38	59,61								
2.900	38,08	46,02	54,44									
3.000	38,63	46,56										
3.500	40,19											

**$P_a$  (kW) referred to  $i$**

RPM / $i$	1,00/1,01	1,02/1,05	1,06/1,26	1,27/1,57	OVER 1,57
100	0,00	0,01	0,07	0,10	0,12
200	0,00	0,02	0,14	0,20	0,25
300	0,00	0,03	0,21	0,30	0,37
400	0,00	0,04	0,28	0,41	0,49
500	0,00	0,06	0,35	0,51	0,61
600	0,00	0,07	0,42	0,61	0,74
700	0,00	0,08	0,49	0,71	0,86
900	0,00	0,10	0,64	0,91	1,10
1.000	0,00	0,11	0,71	1,01	1,23
1.400	0,00	0,15	0,99	1,42	1,72
1.500	0,00	0,17	1,06	1,52	1,84
1.700	0,00	0,19	1,20	1,72	2,08
1.800	0,00	0,20	1,27	1,82	2,21
2.000	0,00	0,22	1,41	2,03	2,45
2.500	0,00	0,28	1,76	2,53	3,07
2.900	0,00	0,32	2,05	2,94	3,56
3.000	0,00	0,33	2,12	3,04	3,68
3.500	0,00	0,39	2,47	3,55	4,29

\* Belt speed is greater than 30 m/s then is necessary to use dynamically balanced pulleys. A reduction in belt life can be expected. Suggested a smaller section.

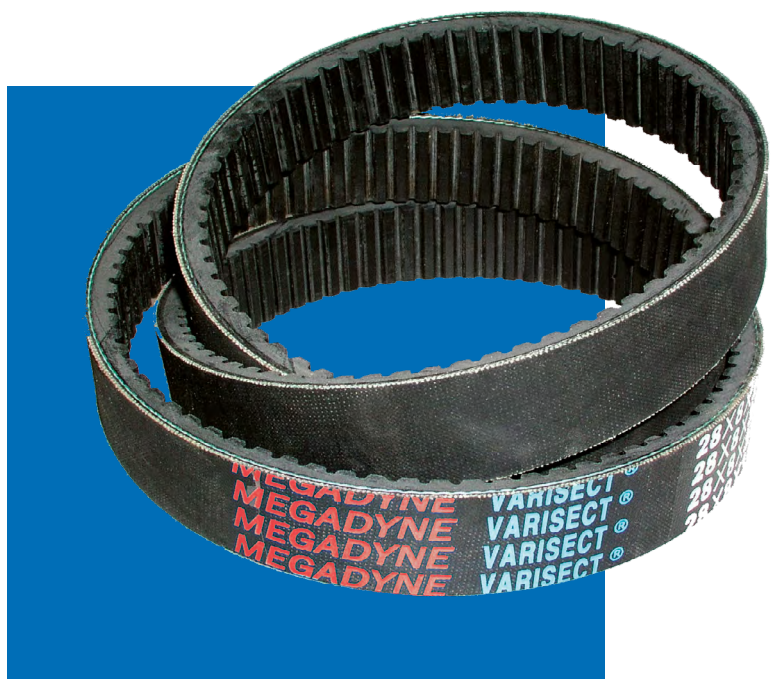

MEGADYNE V-BELTS

# VARIABLE SPEED V-BELTS

VARISECT

# VARIABLE SPEED V-BELTS

## VARISECT

Varisect belts are designed for variable speed transmissions to obtain a wide range of driven speeds:

- Provides exact speed control.
- Guarantees smooth running.
- Raw edge sidewalls improve gripping action.
- Provide superior resistance to ageing caused by wear, oil, heat, grease, and harmful environmental factors.
- Static dissipating.
- Available in a wide selection of sizes.
- Guarantees a long belt life.

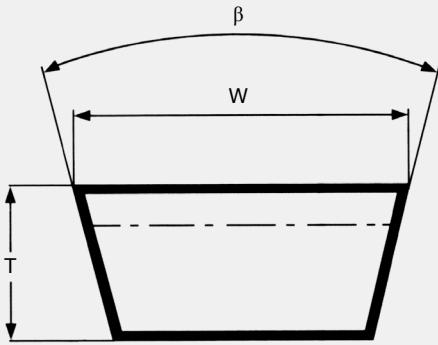

BELT CHARACTERISTICS																
SECTION	13X6	17X6	21X7	22X8	26X8	28X8	30X10	32X10	36X12	37X10	42X13	47X13	52X16	55X16	65X20	70X20
w (mm)	13	17	21	22	26	28	30	32	36	37	42	47	52	55	65	70
T (mm)	6	6	7	8	8	8	10	10	12	10	13	13	16	16	20	20
Pitch length - internal length = $\Delta i$ (mm)	29	29	33	38	38	38	47	47	56	47	61	61	75	75	94	94
External length - pitch length = $\Delta e$ (mm)	9	9	11	12	12	12	16	16	19	16	21	21	25	25	31	31
Iso		W16	W20		W25			W31,5			W40		W50		W63	
Ss (°)	26	26	26	26	26	26	26	26	30	30	30	30	30	30	30	30
Working temperature	-30°C / +90°C															
Relevant standards	ISO 1604 (for W... type only)															
Relevant antistatic standard	ISO 1813															
Materials	CR blend - polyester cord															

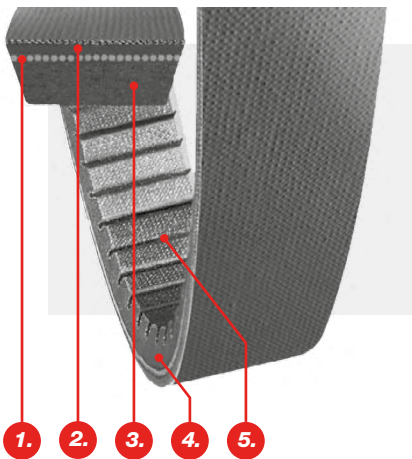

### 1. High-modulus cords

Located in the strength section to carry high HP loads with minimum belt stretch. Resists fatigue and shock. Provides excellent belt stability. Reduces the need for take-up adjustments.

### 2. Fabric tension section

Stretches up to 175% more than ordinary bias-cut fabric to significantly improve the belt flex life.

### 3. Special compound compression section

Provides uniform cord support and crosswise rigidity to lengthen belt life.

### 4. Raw-edge sidewalls

Improve gripping contact with pulley sidewalls. Assure less vibration. Smoother, quieter performance.

### 5. Precision molded cogs

Provide more surface area for heat dissipation and increase belt flexibility. Cooler operation means longer flex life.

# VARIABLE SPEED V-BELTS

## VARISECT

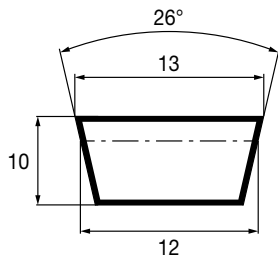

### 13X6 SECTION

CODE	INTERNAL LENGTH LI (mm)
13x6x425	425
13x6x500	500
13x6x525	525
13x6x550	550

### 13X6 SECTION

CODE	INTERNAL LENGTH LI (mm)
13x6x650	650
13x6x675	675
13x6x700	700
13x6x725	725

### 13X6 SECTION

CODE	INTERNAL LENGTH LI (mm)
13x6x750	750
13x6x775	775
13x6x900	900

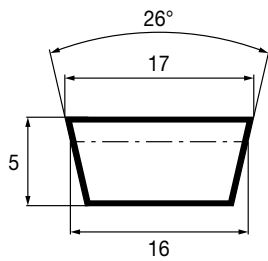

### 17X6 W16 SECTION

CODE	PITCH LENGTH LD (mm)
16 W 450	450
16 W 500	500
16 W 560	560

### 17X6 W16 SECTION

CODE	PITCH LENGTH LD (mm)
16 W 600	600
16 W 630	630
16 W 710	710

### 17X6 W16 SECTION

CODE	PITCH LENGTH LD (mm)
16 W 800	800
16 W 900	900
16 W 1000	1000

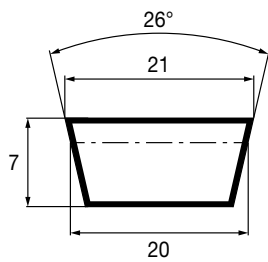

### 21X7 W20 SECTION

CODE	PITCH LENGTH LD (mm)
20 W 560	560
20 W 630	630
20 W 640	640

### 21X7 W20 SECTION

CODE	PITCH LENGTH LD (mm)
20 W 710	710
20 W 800	800
20 W 900	900

### 21X7 W20 SECTION

CODE	PITCH LENGTH LD (mm)
20 W 1000	1000
20 W 1120	1120
20 W 1250	1250

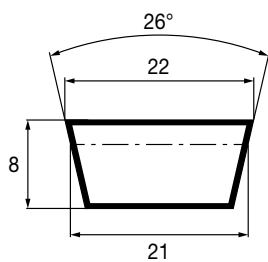

### 22X8 SECTION

CODE	INTERNAL LENGTH LI (mm)
22X8 X500	500
22X8 X525	525
22X8 X550	550
22X8 X575	575
22X8 X600	600
22X8 X610	610
22X8 X625	625
22X8 X650	650
22X8 X675	675

### 22X8 SECTION

CODE	INTERNAL LENGTH LI (mm)
22X8 X700	700
22X8 X725	725
22X8 X750	750
22X8 X800	800
22X8 X850	850
22X8 X900	900
22X8 X950	950
22X8 X1000	1000
22X8 X1060	1060

### 22X8 SECTION

CODE	INTERNAL LENGTH LI (mm)
22X8 X1120	1120
22X8 X1180	1180
22X8 X1250	1250
22X8 X1320	1320
22X8 X1400	1400
22X8 X1500	1500
22X8 X1600	1600
22X8 X2000	2000

# VARIABLE SPEED V-BELTS

## VARISECT

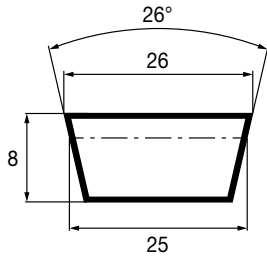

### 26X8 W25 SECTION

CODE	PITCH LENGTH LD (mm)
25 W 560	560
25 W 690	690
25 W 710	710
25 W 750	750

### 26X8 W25 SECTION

CODE	PITCH LENGTH LD (mm)
25 W 790	790
25 W 800	800
25 W 900	900
25 W 1000	1000

### 26X8 W25 SECTION

CODE	PITCH LENGTH LD (mm)
25 W 1120	1120
25 W 1250	1250
25 W 1400	1400
25 W 1600	1613

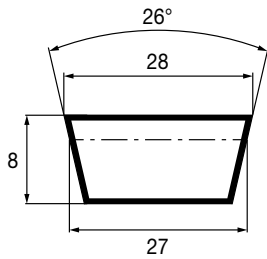

### 28X8 SECTION

CODE	INTERNAL LENGTH LI (mm)
28X8 X525	525
28X8 X600	600
28X8 X625	625
28X8 X650	650
28X8 X700	700
28X8 X750	750
28X8 X800	800

### 28X8 SECTION

CODE	INTERNAL LENGTH LI (mm)
28X8 X850	850
28X8 X900	900
28X8 X950	950
28X8 X1000	1000
28X8 X1060	1060
28X8 X1120	1120
28X8 X1180	1180

### 28X8 SECTION

CODE	INTERNAL LENGTH LI (mm)
28X8 X1250	1250
28X8 X1320	1320
28X8 X1400	1400
28X8 X1500	1500
28X8 X1600	1600
28X8 X1700	1700

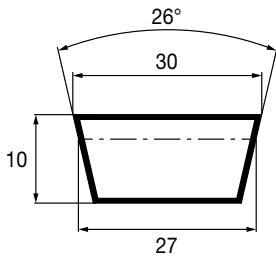

### 30X10 SECTION

CODE	INTERNAL LENGTH LI (mm)
30X10X650	650
30X10X665	665
30X10X700	700
30X10X800	800
30X10X850	850
30X10X875	875

### 30X10 SECTION

CODE	INTERNAL LENGTH LI (mm)
30X10X900	900
30X10X950	950
30X10X1000	1000
30X10X1035	1035
30X10X1050	1050
30X10X1120	1120

### 30X10 SECTION

CODE	INTERNAL LENGTH LI (mm)
30X10X1200	1200
30X10X1320	1320
30X10X1340	1340
30X10X1500	1500
30X10X1600	1600

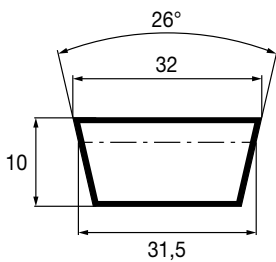

### 32X10 W31,5 SECTION

CODE	PITCH LENGTH LD (mm)
31,5 W 800	800
31,5 W 840	840
31,5 W 870	870
31,5 W 900	900
31,5 W 950	950
31,5 W 1000	1000

### 32X10 W31,5 SECTION

CODE	PITCH LENGTH LD (mm)
31,5 W 1050	1050
31,5 W 1120	1120
31,5 W 1250	1250
31,5 W 1400	1400
31,5 W 1600	1600
31,5 W 1800	1800

### 32X10 W31,5 SECTION

CODE	PITCH LENGTH LD (mm)
31,5 W 2000	2000
22X8 X1500	1500
22X8 X1600	1600
22X8 X2000	2000

# VARIABLE SPEED V-BELTS

## VARISECT

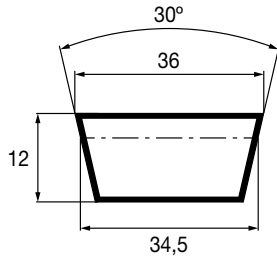

### 36X12 SECTION

CODE	INTERNAL LENGTH LI (mm)
36X12X700	700
36X12X725	725
36X12X800	800
36X12X850	850
36X12X900	900
36X12X950	950
36X12X1000	1000

### 36X12 SECTION

CODE	INTERNAL LENGTH LI (mm)
36X12X1060	1060
36X12X1120	1120
36X12X1180	1180
36X12X1250	1250
6X12X1320	1320
36X12X1400	1400
36X12X1500	1500

### 36X12 SECTION

CODE	INTERNAL LENGTH LI (mm)
36X12X1600	1600
36X12X1700	1700
6X12X1800	1800
6X12X2000	2000
6X12X2120	2120

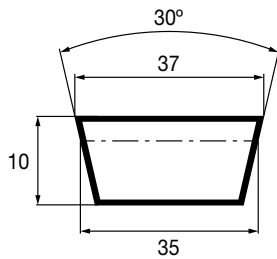

### 37X10 SECTION

CODE	INTERNAL LENGTH LI (mm)
37X10X600	600
37X10X650	650
37X10X675	675
37X10X750	750
37X10X800	800
37X10X850	850
37X10X900	900
37X10X950	950

### 37X10 SECTION

CODE	INTERNAL LENGTH LI (mm)
37X10X1000	1000
37X10X1060	1060
37X10X1120	1120
37X10X1180	1180
37X10X1250	1250
37X10X1320	1320
37X10X1400	1400
37X10X1500	1500

### 37X10 SECTION

CODE	INTERNAL LENGTH LI (mm)
37X10X1600	1600
37X10X1700	1700
37X10X1800	1800
37X10X1900	1900
37X10X2000	2000
37X10X2240	2240

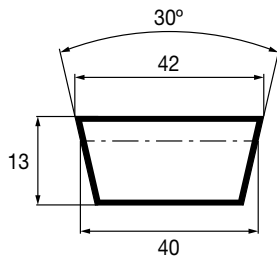

### 42X13 W40 SECTION

CODE	PITCH LENGTH LD (mm)
40 W 1060	1060
40 W 1100	1100
40 W 1120	1120
40 W 1180	1180

### 42X13 W40 SECTION

CODE	PITCH LENGTH LD (mm)
40 W 1250	1250
40 W 1400	1400
40 W 1600	1600
40 W 1660	1660

### 42X13 W40 SECTION

CODE	PITCH LENGTH LD (mm)
40 W 1800	1820
40 W 2000	2000
40 W 2240	2240
40 W 2500	2500

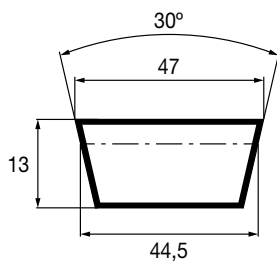

### 47X13 SECTION

CODE	INTERNAL LENGTH LI (mm)
47X13X900	900
47X13X950	950
47X13X1000	1000
47X13X1060	1060
47X13X1120	1120
47X13X1180	1180

### 47X13 SECTION

CODE	INTERNAL LENGTH LI (mm)
47X13X1250	1250
47X13X1320	1320
47X13X1400	1400
47X13X1500	1500
47X13X1600	1600
47X13X1700	1700

### 47X13 SECTION

CODE	INTERNAL LENGTH LI (mm)
47X13X1800	1800
47X13X1900	1900
47X13X2000	2000
47X13X2240	2240

# VARIABLE SPEED V-BELTS

## VARISECT

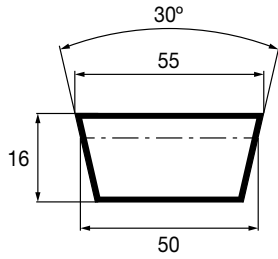

### 52X16 W50 SECTION

CODE	PITCH LENGTH LD (mm)
50 W 1250	1250
50 W 1400	1400
50 W 1600	1600

### 52X16 W50 SECTION

CODE	PITCH LENGTH LD (mm)
50 W 1800	1800
50 W 2000	2000
50 W 2240	2240

### 52X16 W50 SECTION

CODE	PITCH LENGTH LD (mm)
50 W 2500	2500
50 W 2800	2800
50 W 3150	3150

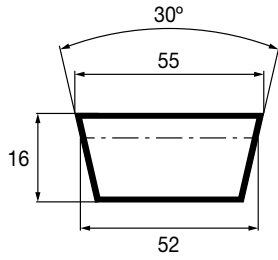

### 55X16 SECTION

CODE	INTERNAL LENGTH LI (mm)
55X16X1180	1180
55X16X1250	1250
55X16X1400	1400

### 55X16 SECTION

CODE	INTERNAL LENGTH LI (mm)
55X16X1600	1600
55X16X1700	1700
55X16X1800	1800

### 55X16 SECTION

CODE	INTERNAL LENGTH LI (mm)
55X16X2000	2000
55X16X2240	2240

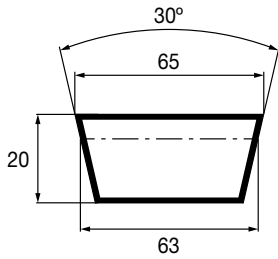

### 65X20 W63 SECTION

CODE	PITCH LENGTH LD (mm)
63 W 1600	1600
63 W 1800	1800
63 W 2000	2000

### 65X20 W63 SECTION

CODE	PITCH LENGTH LD (mm)
63 W 2240	2240
63 W 2500	2500
63 W 2800	2800

### 65X20 W63 SECTION

CODE	PITCH LENGTH LD (mm)
63 W 3150	3150
63 W 3550	3550
63 W 4000	4000

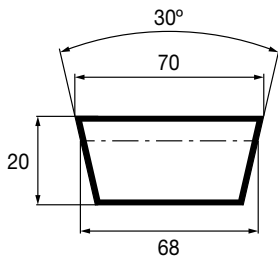

### 70X20 SECTION

CODE	INTERNAL LENGTH LI (mm)
70X20X1320	1320
70X20X1400	1400
70X20X1445	1445
70X20X1500	1500
70X20X1600	1600

### 70X20 SECTION

CODE	INTERNAL LENGTH LI (mm)
70X20X1700	1700
70X20X1800	1800
70X20X1900	1900
70X20X2000	2000
70X20X2120	2120

### 70X20 SECTION

CODE	INTERNAL LENGTH LI (mm)
70X20X2240	2240
70X20X2360	2360
70X20X2500	2500
70X20X2800	2800



MEGADYNE V-BELTS

# DOUBLE V-BELTS

ESAFLEX

# DOUBLE V-BELTS

## ESAFLEX

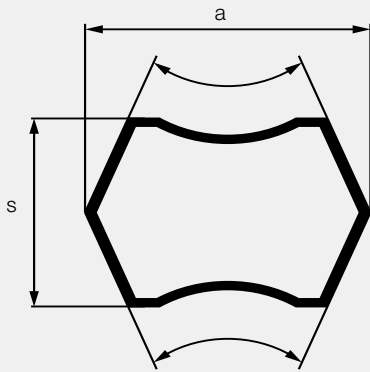

### BELTS CHARACTERISTICS

SECTION	AA	BB	CC
<b>a (mm)</b>	13	17	22
<b>s (mm)</b>	10	14	19
<b>Pitch length - internal length = <math>\Delta i</math> (mm)</b>	31,4	44	55
<b>External length - pitch length = <math>\Delta e</math> (mm)</b>	31,4	44	55
<b>weight (gr/m)</b>	150	238	429
<b>Min. Pulley diam. (Mm)</b>	80	140	224
<b>Working temperature</b>	-30°C / +80°C		
<b>Relevant standards</b>	ARPM/MPTA IP2 21 - DIN 7722 - ISO 5289		
<b>Relevant antistatic standard</b>	ISO 1813		
<b>Materials</b>	CR blend - polyester cord - cotton/polyester fabric		

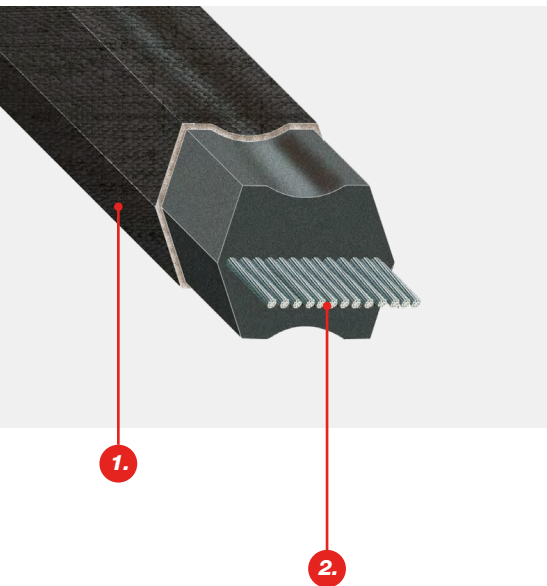

## DOUBLE ANGLE V-BELT

Ideally suited for serpentine drives where power needs to be transmitted equally from both sides of the belt. Double wrapped cotton-neoprene cover is added for excellent resistance to abrasive wear, heat, ozone, sunlight, grease, oil, or dirt.

Centrally located cord and special synthetic rubber compounds assure long belt life and a smooth and capable power capacity.

1. Double-wrapped neoprene and cotton fabric
2. The core of the belt is made of a special blend of compounds to provide a long life and a superior power capacity

# DOUBLE V-BELTS

## ESAFLEX

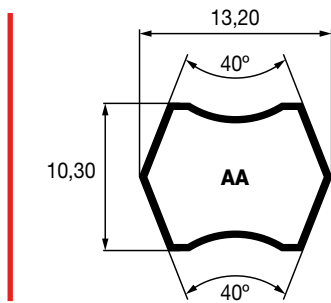

AA SECTION	
CODE	LP (mm)
AA 51	1350
AA 60	1580
AA 61	1600
AA 68	1780
AA 71	1855
AA 75	1955
AA 77	2010
AA 80	2085
AA 81	2110

AA SECTION	
CODE	LP (mm)
AA 85	2210
AA86	2240
AA88	2290
AA 90	2340
AA 91	2365
AA 95	2465
AA 96	2490
AA 105	2720
AA 108	2800

AA SECTION	
CODE	LP (mm)
AA 112	2895
AA 116	3000
AA 120	3100
AA 128	3305
AA 147	3785
AA 148	3810
AA 152	3915
AA 159	4090
AA 163	4195

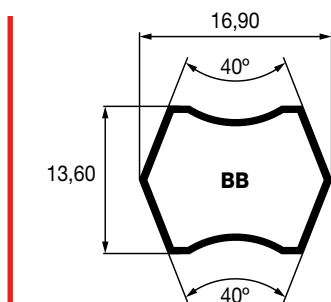

BB SECTION	
CODE	LP (mm)
BB 50	1345
BB 60	1600
BB 68	1805
BB 71	1880
BB 75	1980
BB 81	2130
BB 85	2235
BB 90	2360
BB 92	2415
BB 94	2465
BB 97	2540
BB 105	2745

BB SECTION	
CODE	LP (mm)
BB 107	2791
BB 112	2920
BB 118	3075
BB 120	3125
BB 121	3150
BB 122	3175
BB 128	3330
BB 135	3505
BB 144	3735
BB 154	3990
BB 155	4015
BB 158	4090

BB SECTION	
CODE	LP (mm)
BB 162	4190
BB 173	4470
BB 174	4495
BB 180	4650
BB 184	4750
BB 190	4900
BB 195	5030
BB 210	5410
BB 221	5690
BB 240	6135
BB 270	6895

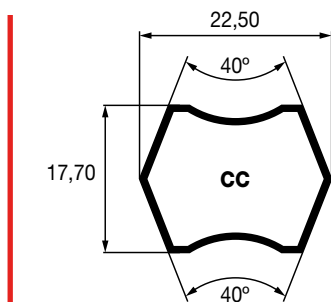

CC SECTION	
CODE	LP (mm)
CC 81	2160
CC 85	2265
CC 86	2290
CC 96	2245
CC 105	2770
CC 112	2950
CC 120	3150
CC 128	3355
CC 144	3760

CC SECTION	
CODE	LP (mm)
CC 153	3990
CC 158	4120
CC 162	4220
CC 173	4500
CC 179	4655
CC 180	4680
CC 193	5010
CC 195	5060
CC 210	5440

CC SECTION	
CODE	LP (mm)
CC 218	5645
CC 234	6000
CC 240	6155
CC 270	6910
CC 300	7675
CC 330	8435
CC 360	9200
CC 390	9960
CC 420	10720



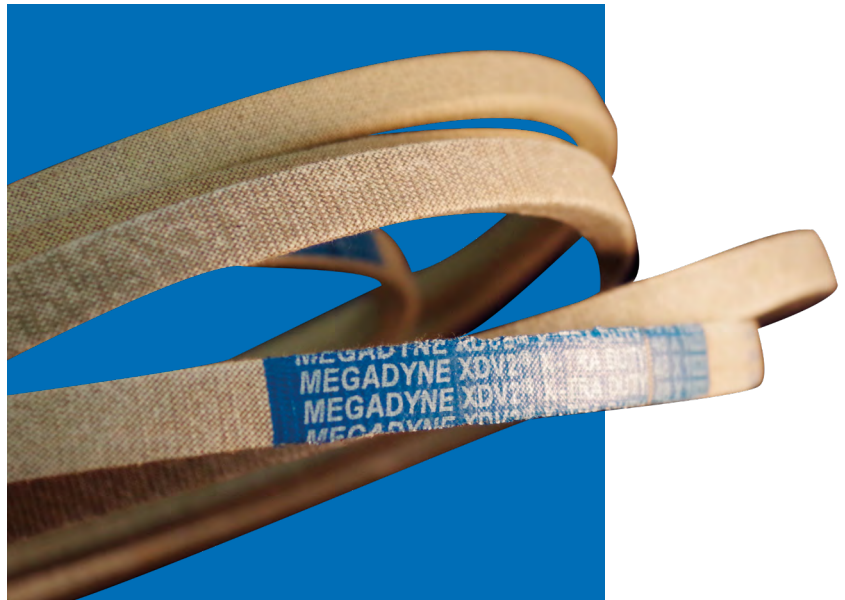

MEGADYNE V-BELTS

# X-TRA DUTY V-BELTS

XDV2

# X-TRA DUTY V-BELTS

## XDV2

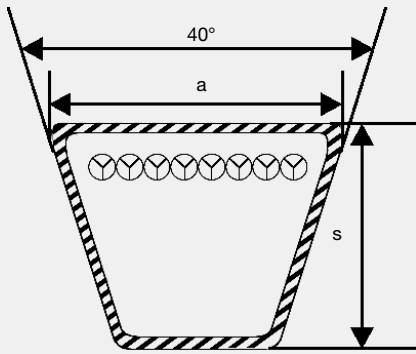

### BELTS CHARACTERISTICS

SECTION	38	48	58
a (mm)	9,5	12,7	15,9
s (mm)	5,5	7,2	9
weight (gr/m)	57	95	143
Working temperature	-20°C / +80°C		
Relevant antistatic standard	ISO 1813		
Materials	CR blend - aramid cord - cotton/polyester fabric		

XDV2 series belts are designed for maintenance-free operation in applications with exceptional hard working conditions.

### BELT FEATURES

- Trouble-free operation on the drives with small pulleys.
- Smooth power transmission due to the belts capacity to absorb power shock.
- Ideal for drives with power oscillations.
- Thanks to the high-grade of its materials the belt gives even better results when used with back-side idlers.
- Made with a strong cotton cover for long-lasting clutching transmissions.
- Low tolerances reduce drive vibrations and allow its use in single or multiple drive transmissions without any restrictions.
- Superior resistance to temperature, oil, and weather.
- Easily identified by its light grey coloured fabric.
- Comes in popular sizes (3/8", 1/2", 5/8").
- Meets requirements for static conductivity.

## XDV2 BELT DRIVES

The XDV2 belt has been created for drives that include small pulley diameters and high-temperature peaks, combined with a high-grade of moisture and humidity.

It withstands the harshest environmental requirements, such as oil and grease contaminated drives or transmissions where grits may interfere between the pulleys and the belt.

Thanks to its characteristics, the XDV2 perfectly matches the requirements of clutching drives as the aramid cord protects the belt against shock loads, all while maintaining its length constant.

XDV2 belts are used successfully in applications such as:

- Lawn movers
- Garden tillers
- Snow blowers
- Garden tractors

# X-TRA DUTY V-BELTS

## XDV2

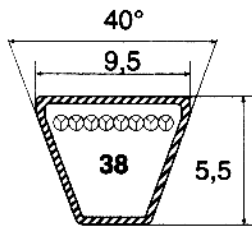

### XDV2- 38 SECTION

CODE	EXTERNAL LENGTH LE (inches)
XDV38 /150	15
XDV38 /160	16
XDV38 /170	17
XDV38 /180	18
XDV38 /190	19
XDV38 /200	20
XDV38 /210	21
XDV38 /220	22
XDV38 /230	23
XDV38 /240	24
XDV38 /250	25
XDV38 /260	26
XDV38 /270	27
XDV38 /280	28
XDV38 /290	29
XDV38 /300	30
XDV38 /310	31
XDV38 /320	32

### XDV2- 38 SECTION

CODE	EXTERNAL LENGTH LE (inches)
XDV38 /330	33
XDV38 /340	34
XDV38 /350	35
XDV38 /360	36
XDV38 /370	37
XDV38 /380	38
XDV38 /390	39
XDV38 /400	40
XDV38 /410	41
XDV38 /420	42
XDV38 /430	43
XDV38 /440	44
XDV38 /450	45
XDV38 /460	46
XDV38 /470	47
XDV38 /480	48
XDV38 /490	49
XDV38 /500	50

### XDV2- 38 SECTION

CODE	EXTERNAL LENGTH LE (inches)
XDV38 /510	51
XDV38 /520	52
XDV38 /530	53
XDV38 /540	54
XDV38 /550	55
XDV38 /560	56
XDV38 /570	57
XDV38 /580	58
XDV38 /590	59
XDV38 /600	60
XDV38 /610	61
XDV38 /620	62
XDV38 /630	63
XDV38 /690	69
XDV38 /710	71
XDV38 /740	74
XDV38 /750	75

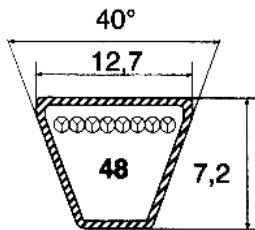

### XDV2-48 SECTION

CODE	EXTERNAL LENGTH LE (inches)
XDV48 /170	17
XDV48 /180	18
XDV48 /190	19
XDV48 /200	20
XDV48 /210	21
XDV48 /220	22
XDV48 /230	23
XDV48 /240	24
XDV48 /250	25
XDV48 /260	26
XDV48 /270	27
XDV48 /280	28
XDV48 /290	29
XDV48 /300	30
XDV48 /310	31
XDV48 /320	32
XDV48 /330	33
XDV48 /340	34
XDV48 /350	35
XDV48 /360	36
XDV48 /370	37
XDV48 /380	38
XDV48 /390	39
XDV48 /400	40
XDV48 /410	41
XDV48 /420	42
XDV48 /430	43
XDV48 /440	44
XDV48 /450	45
XDV48 /460	46

### XDV2-48 SECTION

CODE	EXTERNAL LENGTH LE (inches)
XDV48 /470	47
XDV48 /480	48
XDV48 /490	49
XDV48 /500	50
XDV48 /510	51
XDV48 /520	52
XDV48 /530	53
XDV48 /540	54
XDV48 /550	55
XDV48 /560	56
XDV48 /570	57
XDV48 /580	58
XDV48 /590	59
XDV48 /600	60
XDV48 /610	61
XDV48 /620	62
XDV48 /630	63
XDV48 /640	64
XDV48 /650	65
XDV48 /660	66
XDV48 /670	67
XDV48 /680	68
XDV48 /690	69
XDV48 /700	70
XDV48 /710	71
XDV48 /720	72
XDV48 /730	73
XDV48 /740	74
XDV48 /750	75
XDV48 /760	76

### XDV2-48 SECTION

CODE	EXTERNAL LENGTH LE (inches)
XDV48 /770	77
XDV48 /780	78
XDV48 /790	79
XDV48 /800	80
XDV48 /810	81
XDV48 /820	82
XDV48 /830	83
XDV48 /840	84
XDV48 /850	85
XDV48 /860	86
XDV48 /870	87
XDV48 /880	88
XDV48 /890	89
XDV48 /900	90
XDV48 /910	91
XDV48 /920	92
XDV48 /930	93
XDV48 /940	94
XDV48 /950	95
XDV48 /960	96
XDV48 /970	97
XDV48 /980	98
XDV48 /990	99
XDV48 /1000	100
XDV48 /1050	105
XDV48 /1070	107
XDV48 /1140	114
XDV48 /1170	117

# X-TRA DUTY V-BELTS

## XDV2

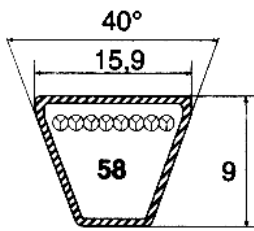

XDV2-58 SECTION	
CODE	EXTERNAL LENGTH LE (inches)
XDV58 /230	23
XDV58 /240	24
XDV58 /250	25
XDV58 /260	26
XDV58 /270	27
XDV58 /280	28
XDV58 /290	29
XDV58 /300	30
XDV58 /310	31
XDV58 /320	32
XDV58 /330	33
XDV58 /340	34
XDV58 /350	35
XDV58 /360	36
XDV58 /370	37
XDV58 /380	38
XDV58 /390	39
XDV58 /400	40
XDV58 /410	41
XDV58 /420	42
XDV58 /430	43
XDV58 /440	44
XDV58 /450	45
XDV58 /460	46
XDV58 /470	47
XDV58 /480	48
XDV58 /490	49

XDV2-58 SECTION	
CODE	EXTERNAL LENGTH LE (inches)
XDV58 /500	50
XDV58 /510	51
XDV58 /520	52
XDV58 /530	53
XDV58 /540	54
XDV58 /550	55
XDV58 /560	56
XDV58 /570	57
XDV58 /580	58
XDV58 /590	59
XDV58 /600	60
XDV58 /610	61
XDV58 /620	62
XDV58 /630	63
XDV58 /640	64
XDV58 /650	65
XDV58 /660	66
XDV58 /670	67
XDV58 /680	68
XDV58 /690	69
XDV58 /700	70
XDV58 /710	71
XDV58 /720	72
XDV58 /730	73
XDV58 /740	74
XDV58 /750	75
XDV58 /760	76

XDV2-58 SECTION	
CODE	EXTERNAL LENGTH LE (inches)
XDV58 /770	77
XDV58 /780	78
XDV58 /790	79
XDV58 /800	80
XDV58 /810	81
XDV58 /820	82
XDV58 /830	83
XDV58 /840	84
XDV58 /850	85
XDV58 /860	86
XDV58 /870	87
XDV58 /880	88
XDV58 /890	89
XDV58 /900	90
XDV58 /910	91
XDV58 /920	92
XDV58 /930	93
XDV58 /940	94
XDV58 /950	95
XDV58 /960	96
XDV58 /970	97
XDV58 /980	98
XDV58 /990	99
XDV58 /1000	100
XDV58 /1030	103
XDV58 /1080	108



MEGADYNE V-BELTS

# BANDED V-BELTS

PLURIBAND

# BANDED V-BELTS

## PLURIBAND

Pluriband are special belts capable of transmitting very high loads. The structure is made to be equivalent in performance to several corresponding V-belts: a Pluriband A47-1200-5 has the same performance as 5 A47 belts working in parallel. The procedure for engineering a system using Pluriband belts is the same as described in the technical calculation chapter, using the same performance data as the corresponding V-belt profile.

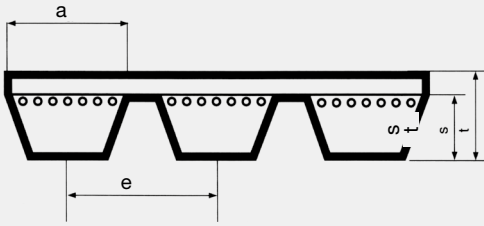

BELT CHARACTERISTICS												
SECTION	RA	RB	RC	RSPZ	RSPA	RSPB	RSPC	R3V	R5V	R8V	R3VX	R5VX
a (mm)	13	17	22	9.7	12.7	16.3	22	9	15	25	9	15
s (mm)	8	11	14	8	10	13	18	8	13	23	8	13
t (mm)	10	13	16	10,5	12,5	15,5	22,5	10	15	25,5	10	15
e (mm ± 0,3)	15	19	25.5	12	15	19	25,5	10,3	17,5	28,6	10,3	17,5
Pitch length - internal length = i (mm)	33	43	62	39	47	61	86	31	54	103		
Working temperature	-30°C / +80°C											
Relevant standards	ASAE S 211.4 - ISO 8419											
Materials	CR / SBR blend - polyester cord											

## PLURIBAND

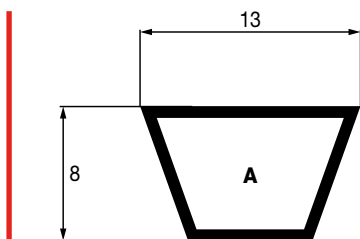

RA SECTION	
CODE	INTERNAL LENGTH LI (mm)
RA 47	1200
RA 51	1300
RA 56	1422
RA 57	1450
RA 59	1500
RA 64	1625
RA 67	1700
RA 71	1800

RA SECTION	
CODE	INTERNAL LENGTH LI (mm)
RA 75	1900
RA 79	2000
RA 88	2240
RA 98	2500
RA 100	2540
RA 104	2650
RA 112	2845
RA 120	3048

RA SECTION	
CODE	INTERNAL LENGTH LI (mm)
RA 128	3250
RA 144	3658
RA 158	4000
RA 167	4250
RA 187	4750
RA 197	5000
RA 210	5334
RA 217	5477

# BANDED V-BELTS

## PLURIBAND

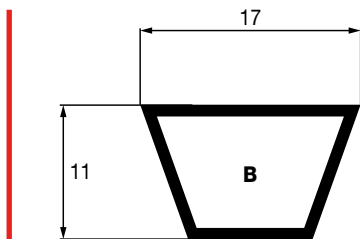

RB SECTION	
CODE	INTERNAL LENGTH LI (mm)
RB 70	1778
RB 71	1803
RB 72	1829
RB 73	1854
RB 74	1880
RB 75	1905
RB 76	1930
RB 78	1981
RB 79	2007
RB 80	2032
RB 81	2057
RB 82	2083
RB 83	2108
RB 84	2134
RB 85	2159
RB 86	2184
RB 87	2210
RB 88	2235
RB 89	2261
RB 90	2286
RB 91	2311
RB 92	2337
RB 93	2362
RB 94	2388
RB 95	2413
RB 96	2438

RB SECTION	
CODE	INTERNAL LENGTH LI (mm)
RB 97	2464
RB 98	2489
RB 99	2515
RB 100	2540
RB 102	2591
RB 104	2642
RB 105	2667
RB 106	2692
RB 107	2718
RB 108	2743
RB 110	2794
RB 112	2845
RB 114	2896
RB 115	2921
RB 116	2946
RB 118	2997
RB 120	3048
RB 124	3150
RB 127	3226
RB 128	3251
RB 130	3302
RB 131	3327
RB 132	3353
RB 133	3378
RB 134	3404
RB 135	3429

RB SECTION	
CODE	INTERNAL LENGTH LI (mm)
RB 136	3454
RB 140	3556
RB 144	3658
RB 147	3734
RB 148	3759
RB 151	3835
RB 152	3861
RB 154	3912
RB 157	3988
RB 158	4013
RB 161	4089
RB 162	4115
RB 163	4140
RB 165	4191
RB 167	4242
RB 168	4267
RB 173	4394
RB 175	4445
RB 177	4496
RB 180	4572
RB 186	4724
RB 188	4775
RB 192	4877
RB 195	4953
RB 197	5004

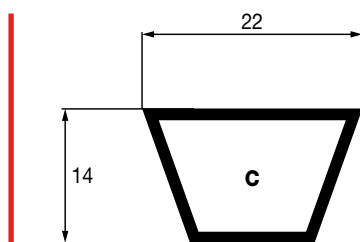

RC SECTION	
CODE	INTERNAL LENGTH LI (mm)
RC 98	2489
RC 99	2515
RC 100	2540
RC 101	2565
RC 102	2591
RC 104	2642
RC 105	2667
RC 106	2692
RC 108	2743
RC 110	2794
RC 112	2845

RC SECTION	
CODE	INTERNAL LENGTH LI (mm)
RC 115	2921
RC 118	2997
RC 120	3048
RC 124	3150
RC 128	3251
RC 130	3302
RC 134	3404
RC 136	3454
RC 140	3556
RC 142	3607
RC 144	3658

RC SECTION	
CODE	INTERNAL LENGTH LI (mm)
RC 148	3759
RC 153	3886
RC 158	4013
RC 160	4064
RC 165	4191
RC 166	4216
RC 168	4267
RC 173	4394
RC 180	4572
RC 195	4953
RC 210	5334

# BANDED V-BELTS

## PLURIBAND

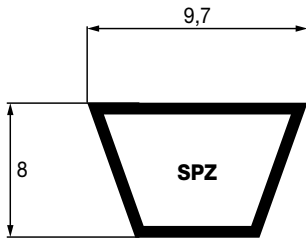

RSPZ SECTION	
CODE	PITCH LENGTH LD (mm)
RSPZ 1400	1400
RSPZ 1500	1500
RSPZ 1600	1600
RSPZ 1700	1700
RSPZ 1800	1800
RSPZ 1900	1900

RSPZ SECTION	
CODE	PITCH LENGTH LD (mm)
RSPZ 2000	2000
RSPZ 2120	2120
RSPZ 2240	2240
RSPZ 2360	2360
RSPZ 2500	2500
RSPZ 2650	2650

RSPZ SECTION	
CODE	PITCH LENGTH LD (mm)
RSPZ 2800	2800
RSPZ 3000	3000
RSPZ 3150	3150
RSPZ 3350	3350
RSPZ 3550	3550

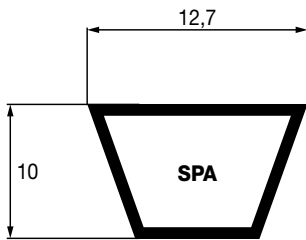

RSPA SECTION	
CODE	PITCH LENGTH LD (mm)
RSPA 1500	1500
RSPA 1600	1600
RSPA 1700	1700
RSPA 1800	1800
RSPA 1900	1900
RSPA 2000	2000
RSPA 2120	2120

RSPA SECTION	
CODE	PITCH LENGTH LD (mm)
RSPA 2240	2240
RSPA 2360	2360
RSPA 2500	2500
RSPA 2650	2650
RSPA 2800	2800
RSPA 3000	3000
RSPA 3150	3150

RSPA SECTION	
CODE	PITCH LENGTH LD (mm)
RSPA 3350	3350
RSPA 3550	3550
RSPA 3750	3750
RSPA 4000	4000
RSPA 4250	4250
RSPA 4500	4500

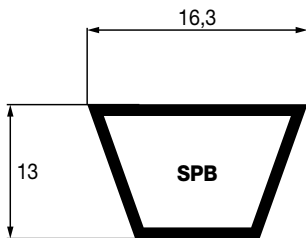

RSPB SECTION	
CODE	PITCH LENGTH LD (mm)
RSPB 2000	2000
RSPB 2120	2120
RSPB 2240	2240
RSPB 2360	2360
RSPB 2500	2500
RSPB 2650	2650
RSPB 2800	2800
RSPB 3000	3000
RSPB 3150	3150

RSPB SECTION	
CODE	PITCH LENGTH LD (mm)
RSPB 3350	3350
RSPB 3550	3550
RSPB 3750	3750
RSPB 4000	4000
RSPB 4250	4250
RSPB 4500	4500
RSPB 4750	4750
RSPB 5000	5000
RSPB 5300	5300

RSPB SECTION	
CODE	PITCH LENGTH LD (mm)
RSPB 5600	5600
RSPB 6000	6000
RSPB 6300	6300
RSPB 6700	6700
RSPB 7100	7100
RSPB 7500	7500
RSPB 8000	8000

# BANDED V-BELTS

## PLURIBAND

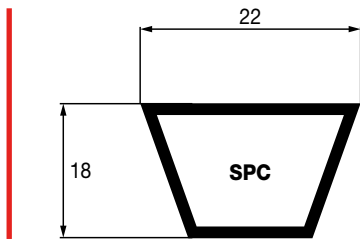

RSPC SECTION	
CODE	PITCH LENGTH LD (mm)
RSPC 3000	3000
RSPC 3150	3150
RSPC 3350	3350
RSPC 3550	3550
RSPC 3750	3750
RSPC 4000	4000
RSPC 4250	4250
RSPC 4500	4500
RSPC 4750	4750

RSPC SECTION	
CODE	PITCH LENGTH LD (mm)
RSPC 5000	5000
RSPC 5300	5300
RSPC 5600	5600
RSPC 6000	6000
RSPC 6300	6300
RSPC 6700	6700
RSPC 7100	7100
RSPC 7500	7500
RSPC 8000	8000

RSPC SECTION	
CODE	PITCH LENGTH LD (mm)
RSPC 8500	8500
RSPC 9000	9000
RSPC 9500	9500
RSPC 10000	10000
RSPC 10600	10600
RSPC 11200	11200
RSPC 11800	11800
RSPC 12500	12500

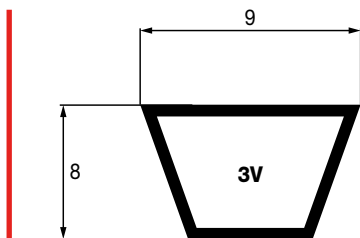

R3V SECTION	
CODE	EXTERNAL LENGTH LE (mm)
R3V 335	850
R3V 355	900
R3V 375	950
R3V 400	1015
R3V 425	1080
R3V 450	1145
R3V 475	1205
R3V 500	1270
R3V 530	1345

R3V SECTION	
CODE	EXTERNAL LENGTH LE (mm)
R3V 560	1420
R3V 600	1525
R3V 630	1600
R3V 670	1700
R3V 710	1800
R3V 750	1900
R3V 800	2030
R3V 850	2160
R3V 900	2290

R3V SECTION	
CODE	EXTERNAL LENGTH LE (mm)
R3V 950	2410
R3V 1000	2540
R3V 1060	2690
R3V 1120	2840
R3V 1180	3000
R3V 1250	3180
R3V 1320	3350
R3V 1400	3550

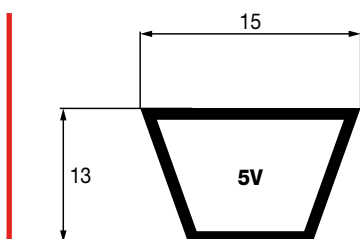

R5V SECTION	
CODE	EXTERNAL LENGTH LE (mm)
R5V 500	1270
R5V 530	1345
R5V 560	1420
R5V 600	1525
R5V 630	1600
R5V 670	1700
R5V 710	1800
R5V 750	1900
R5V 800	2030
R5V 850	2160
R5V 900	2290
R5V 950	2410

R5V SECTION	
CODE	EXTERNAL LENGTH LE (mm)
R5V 1000	2540
R5V 1120	2840
R5V 1180	3000
R5V 1250	3180
R5V 1320	3350
R5V 1400	3550
R5V 1500	3810
R5V 1600	4060
R5V 1700	4320
R5V 1800	4570
R5V 1900	4830
R5V 2000	5080

R5V SECTION	
CODE	EXTERNAL LENGTH LE (mm)
R5V 2120	5380
R5V 2240	5690
R5V 2360	6000
R5V 2500	6350
R5V 2650	6730
R5V 2800	7100
R5V 3000	7620
R5V 3150	8000
R5V 3350	8500
R5V 3550	9000

# BANDED V-BELTS

## PLURIBAND

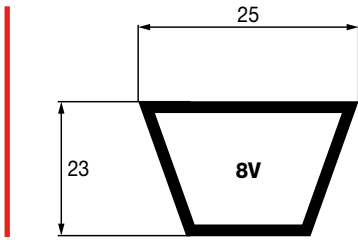

R8V SECTION	
CODE	EXTERNAL LENGTH LE (mm)
R8V 1000	2540
R8V 1060	2690
R8V 1120	2840
R8V 1180	3000
R8V 1250	3180
R8V 1320	3350
R8V 1400	3550
R8V 1500	3810
R8V 1600	4060
R8V 1700	4320
R8V 1800	4570

R8V SECTION	
CODE	EXTERNAL LENGTH LE (mm)
R8V 1900	4830
R8V 2000	5080
R8V 2120	5380
R8V 2240	5690
R8V 2360	6000
R8V 2500	6350
R8V 2650	6730
R8V 2800	7100
R8V 3000	7620
R8V 3150	8000
R8V 3350	8500

R8V SECTION	
CODE	EXTERNAL LENGTH LE (mm)
R8V 3550	9000
R8V 3750	9500
R8V 4000	10160
R8V 4250	10800
R8V 4500	11430
R8V 4750	12060
R8V 5000	12700
R8V 5600	14200
R8V 6000	15250

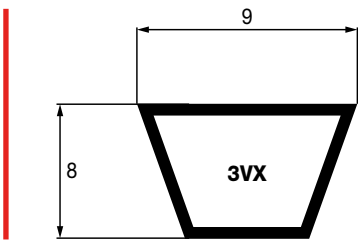

R3VX SECTION	
CODE	EXTERNAL LENGTH LE (mm)
R3VX 250	630
R3VX 265	670
R3VX 280	710
R3VX 300	760
R3VX 315	800
R3VX 335	850
R3VX 355	900
R3VX 375	950
R3VX 400	1015
R3VX 425	1080

R3VX SECTION	
CODE	EXTERNAL LENGTH LE (mm)
R3VX 450	1145
R3VX 475	1205
R3VX 500	1270
R3VX 530	1345
R3VX 560	1420
R3VX 600	1525
R3VX 630	1600
R3VX 670	1700
R3VX 710	1800
R3VX 750	1900

R3VX SECTION	
CODE	EXTERNAL LENGTH LE (mm)
R3VX 800	2030
R3VX 850	2160
R3VX 900	2290
R3VX 950	2410
R3VX 1000	2540
R3VX 1060	2690
R3VX 1120	2840
R3VX 1180	3000
R3VX 1250	3180
R3VX 1320	3350
R3VX 1400	3550

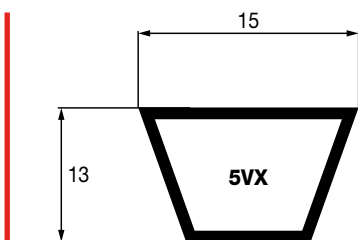

R5VX SECTION	
CODE	EXTERNAL LENGTH LE (mm)
R5VX 500	1270
R5VX 530	1345
R5VX 560	1420
R5VX 600	1525
R5VX 630	1600
R5VX 670	1700
R5VX 710	1800
R5VX 800	2030

R5VX SECTION	
CODE	EXTERNAL LENGTH LE (mm)
R5VX 850	2160
R5VX 900	2290
R5VX 950	2410
R5VX 1000	2540
R5VX 1060	2690
R5VX 1120	2840
R5VX 1180	3000
R5VX 1250	3180

R5VX SECTION	
CODE	EXTERNAL LENGTH LE (mm)
R5VX 1320	3350
R5VX 1400	3550
R5VX 1500	3810
R5VX 1600	4060
R5VX 1700	4320
R5VX 1800	4570
R5VX 1900	4830
R5VX 2000	5080

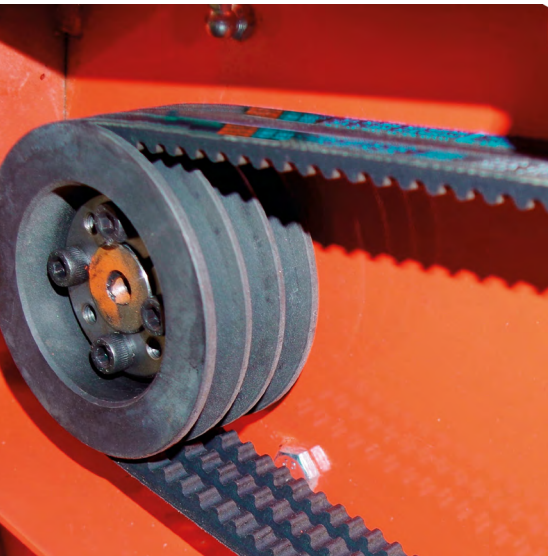

# USEFUL FORMULAS

## AND CONVERSION TABLE

SPEED		
$V = \frac{d_1 \cdot n_1}{19100}$	$n_1 = \frac{V \cdot 19100}{d_1}$	$d_1 = \frac{V \cdot 19100}{n_1}$

**V:** peripheral speed [m/s] | **n1:** rotation speed [RPM] | **d1:** pulley diameter [mm]

FORCES AND TORQUE		
$F_u = \frac{19,1 \cdot 10^6 \cdot P}{d_1 \cdot n_1}$	$F_u = \frac{2000 \cdot M}{d_1}$	$F_u = \frac{P \cdot 10^3}{V}$
$M_t = \frac{P \cdot 9550}{n_1}$	$M_t = \frac{F_u \cdot d_1}{2000}$	$M_t = \frac{P \cdot d_1}{2 \cdot V}$

**Fu:** peripheral force [N] | **Mt:** drive torque [Nm] | **P:** power [kW]  
**n1:** rotation speed [RPM] | **d1:** pulley diameter [mm] | **V:** peripheral speed [m/s]

SPEED		
$P = \frac{F_u \cdot d_1 \cdot n_1}{19,1 \cdot 10^6}$	$P = \frac{M_t \cdot n_1}{9550}$	$P = \frac{F_u \cdot V}{1000}$

**P:** power [kW] | **Fu:** peripheral force [N] | **Mt:** drive torque [Nm]  
**n1:** rotation speed [RPM] | **d1:** pulley diameter [mm]

TO CONVERT FROM	TO	MULTIPLY BY
CV	HP	0,9863201
CV	kcal/h	63,24151
CV	W	735,4988
CV	kW	0,7354988
CV	kgf • m/s	75
CV	lbf • ft/s	542,476
HP	CV	1,01387
HP	kcal/h	641,1865
HP	W	745,6999
HP	kW	0,7456999
HP	kgf • m/s	76,04022
HP	lbf • ft/s	550
in	m	0,0254
in	cm	2,54
in	mm	25,4
in	ft	0,083
in <sup>2</sup>	m <sup>2</sup>	0,00064516
in <sup>2</sup>	cm <sup>2</sup>	6,4516
in <sup>2</sup>	mm <sup>2</sup>	645,16
in <sup>2</sup>	ft <sup>2</sup>	0,006944444
in <sup>3</sup>	m <sup>3</sup>	1,63871•10 <sup>-5</sup>
in <sup>3</sup>	cm <sup>3</sup>	16,38706
in <sup>3</sup>	mm <sup>3</sup>	16387,06
in <sup>3</sup>	ft <sup>3</sup>	0,000578704
J	CV • h	3,77673•10 <sup>-7</sup>

TO CONVERT FROM	TO	MULTIPLY BY
J	HP • h	3,72506•10 <sup>-7</sup>
J	kWh	2,77778•10 <sup>-7</sup>
kg	lb	2,204623
kgf	N	9,80665
kgf	lbf	2,204623
kgf • m/s	CV	0,01333333
kgf • m/s	W	9,80665
kgf • m/s	kW	0,00980665
kW	CV	1,359622
kW	kcal/h	859,8452
kW	W	1000
kW	kgf • m/s	101,9716
kW	lbf • ft/s	737,5621
lb	kg	0,4535924
lb	kgf	0,4535924
lb	N	4,448222
N	kgf	0,1019716
N	lbf	0,2248089
W	CV	0,001359622
W	HP	0,001341022
W	kcal/h	0,8598452
W	kW	0,001
W	kgf • m/s	0,1019716
W	lbf • ft/s	0,7375621

# DATA SHEET

## CUSTOMER DATA

Company Name \_\_\_\_\_ Date \_\_\_\_\_

Address \_\_\_\_\_ Zip Code \_\_\_\_\_

City \_\_\_\_\_ State \_\_\_\_\_ Country \_\_\_\_\_

Customer Name/Surname \_\_\_\_\_

Office \_\_\_\_\_ Tel. \_\_\_\_\_ e-mail \_\_\_\_\_

Application field \_\_\_\_\_  New  Existing\*

Volume \_\_\_\_\_

*\*Please enclose to this request all the details of the existing application (competitor's belt, current data, etc..)*

## TRANSMISSION LAYOUT

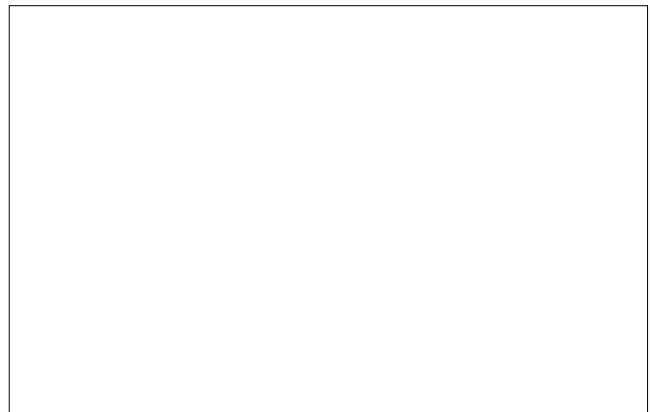
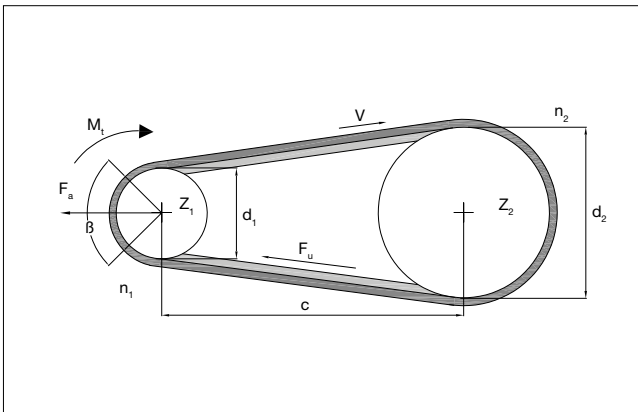

Power transmission

Other (If layout is different please sketch it above)

## DRIVE INFORMATION

AC  DC  Soft Start  Inverter

Power \_\_\_\_\_ Speed \_\_\_\_\_

Torque \_\_\_\_\_ Acceleration \_\_\_\_\_

Working time  < 8h  From 8h up to 16h  24h

Driver pulley's diameter \_\_\_\_\_ Driven pulley's diameter \_\_\_\_\_

Center distance \_\_\_\_\_ Minimum safety factor needed \_\_\_\_\_

Are there any size limitation?  Yes  No

(if yes, please indicate *Max and/or Min diameter, Max and/or Min width and Max and/or Min center distance*):

Min diameter \_\_\_\_\_ Min width \_\_\_\_\_ Min center distance \_\_\_\_\_

Max diameter \_\_\_\_\_ Max width \_\_\_\_\_ Max center distance \_\_\_\_\_

# DATA SHEET

## CUSTOMER DATA

Company Name \_\_\_\_\_ Date \_\_\_\_\_

Address \_\_\_\_\_ Zip Code \_\_\_\_\_

City \_\_\_\_\_ State \_\_\_\_\_ Country \_\_\_\_\_

Customer Name/Surname \_\_\_\_\_

Office \_\_\_\_\_ Tel. \_\_\_\_\_ e-mail \_\_\_\_\_

Application field \_\_\_\_\_  New  Existing\*

Volume \_\_\_\_\_

*\*Please enclose to this request all the details of the existing application (competitor's belt, current data, etc..)*

## TRANSMISSION LAYOUT

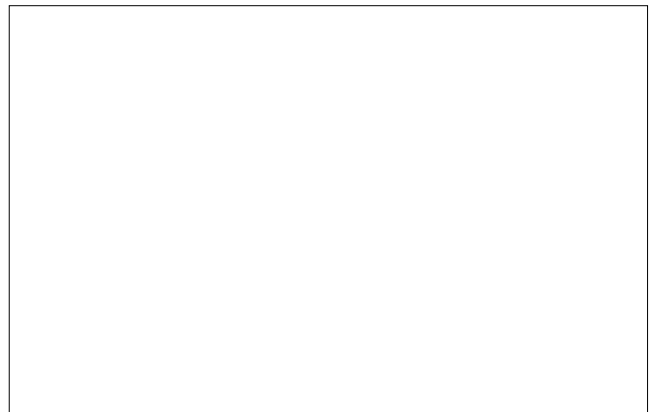
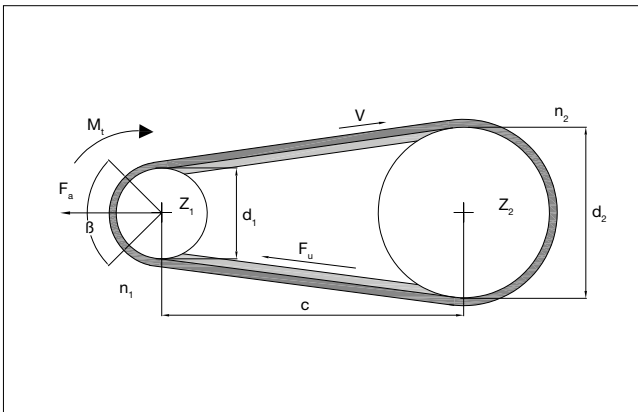

Power transmission

Other (If layout is different please sketch it above)

## DRIVE INFORMATION

AC  DC  Soft Start  Inverter

Power \_\_\_\_\_ Speed \_\_\_\_\_

Torque \_\_\_\_\_ Acceleration \_\_\_\_\_

Working time  < 8h  From 8h up to 16h  24h

Driver pulley's diameter \_\_\_\_\_ Driven pulley's diameter \_\_\_\_\_

Center distance \_\_\_\_\_ Minimum safety factor needed \_\_\_\_\_

Are there any size limitation?  Yes  No

(if yes, please indicate *Max and/or Min diameter, Max and/or Min width and Max and/or Min center distance*):

Min diameter \_\_\_\_\_ Min width \_\_\_\_\_ Min center distance \_\_\_\_\_

Max diameter \_\_\_\_\_ Max width \_\_\_\_\_ Max center distance \_\_\_\_\_

# DATA SHEET

## CUSTOMER DATA

Company Name \_\_\_\_\_ Date \_\_\_\_\_  
 Address \_\_\_\_\_ Zip Code \_\_\_\_\_  
 City \_\_\_\_\_ State \_\_\_\_\_ Country \_\_\_\_\_  
 Customer Name/Surname \_\_\_\_\_  
 Office \_\_\_\_\_ Tel. \_\_\_\_\_ e-mail \_\_\_\_\_  
 Application field \_\_\_\_\_  New  Existing\*  
 Volume \_\_\_\_\_

*\*Please enclose to this request all the details of the existing application (competitor's belt, current data, etc..)*

## TRANSMISSION LAYOUT

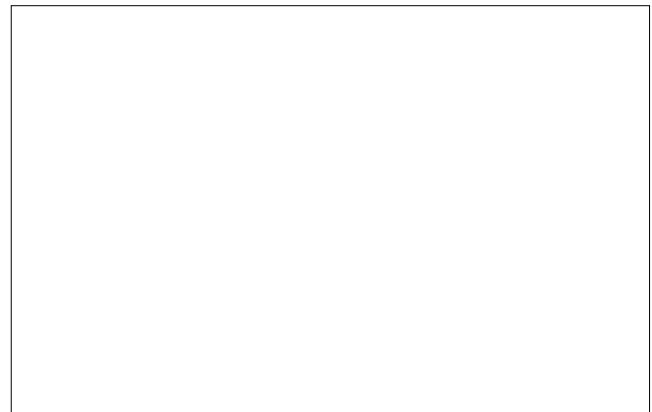
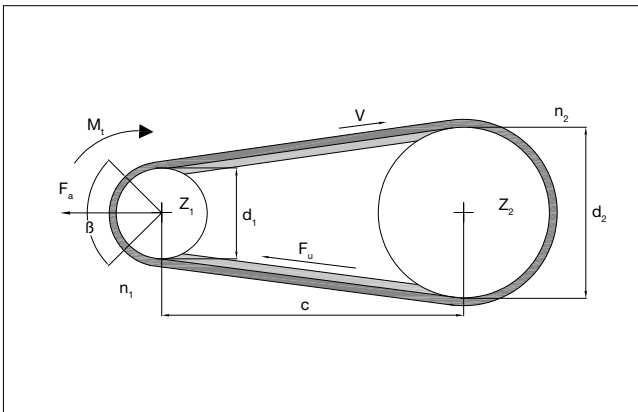

Power transmission

Other (If layout is different please sketch it above)

## DRIVE INFORMATION

AC  DC  Soft Start  Inverter

Power \_\_\_\_\_ Speed \_\_\_\_\_

Torque \_\_\_\_\_ Acceleration \_\_\_\_\_

Working time  < 8h  From 8h up to 16h  24h

Driver pulley's diameter \_\_\_\_\_ Driven pulley's diameter \_\_\_\_\_

Center distance \_\_\_\_\_ Minimum safety factor needed \_\_\_\_\_

Are there any size limitation?  Yes  No

(if yes, please indicate *Max and/or Min diameter, Max and/or Min width and Max and/or Min center distance*):

Min diameter \_\_\_\_\_ Min width \_\_\_\_\_ Min center distance \_\_\_\_\_

Max diameter \_\_\_\_\_ Max width \_\_\_\_\_ Max center distance \_\_\_\_\_

# V-BELTS

The data and information contained in the present catalogue are updated to the date of the catalogue's printing. Ammega Italia S.p.A. reserves the right to modify the specifications, performances and other information relating to the belts described in the present catalogue, at any time at its own discretion, without any prior notice.

For updating refer to our website [www.megadynegroup.com](http://www.megadynegroup.com).

Technical specifications, performances and other information provided in the present catalogue are indicative and do not bound Ammega Italia S.p.A. unless such specifications, performances or other information are expressly agreed in the agreement with the customer.

We also recommend to read carefully the following documents on our web site [www.megadynegroup.com](http://www.megadynegroup.com):

- Ammega Italia S.p.A. General Conditions of Sale (comprising the warranty)
- Theoretical Belt Life.
- Drive Components: Storage, Installation, Maintenance and Troubleshooting Handbook
- Belts standard use condition and temperature.

Copyright Notice: Ammega Italia S.p.A. copyright. All rights reserved.

Ammega Italia S.p.A. is and shall remain the owner of all rights on drawings, technical specifications and any other information contained in the present catalogue or otherwise communicated by Ammega Italia S.p.A. to the customer.

The customer shall not disclose such information to third parties or use such information for purposes different from the definition of the order to Ammega Italia S.p.A., unless upon prior written authorization of Ammega Italia S.p.A.



# Discover Your Local Contacts

The local partner of choice  
for sustainable power transmission belting solutions  
around the globe.

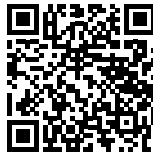

**General contact information:**

**Megadyne**

Via Trieste, 16  
Via S. Lucia 114 - 10075 Mathi (Torino)  
Italy

Scan the QR code  
and find your local  
contact

