



MEGADYNE



WOOD

INDUSTRY
BROCHURE

EN



WOOD INDUSTRY

Our rubber and polyurethane belts support various needs of the wood industry. In this brochure, you will find the overview of the major applications such as sawing, debarking, veneer scarfing and exit transfers, veneer stacker, chipping and MDF preparation, press exit, trimming and inspection.

Megadyne has been catering to your needs since 1957, designing and manufacturing power transmission belts, matched components, and complete belt systems for all types of equipment. We are a reliable partner for original equipment manufacturers and aftermarket distributors, with:

9 manufacturing plants in Europe, North America, and Asia, more than 170 Customer Solution Centres and 3 main distribution hubs around the world, able to deliver products efficiently, from large industrial sites to remote locations.

BELT PROPERTIES



MEGADYNE MEGASYNC™ (GOLD2, SILVER3)

SUPPLIED AS	Endless
LENGTH	248 - 4 956 mm
WIDTH	12 - 170 mm*
PITCH	SLV3 8M, SLV3 14M, GLD2 8M, GLD2 14M
TENSION MEMBER	Fiberglass
FEATURES	High-stability and resistance, antistatic

*Standard Width Range - Megadyne will cut to desired width upon request.



MEGADYNE MEGASYNC™ TITANIUM

SUPPLIED AS	Endless
LENGTH	248 - 4 956 mm
WIDTH	12 - 170 mm*
PITCH	8M, 14M
TENSION MEMBER	Special Carbon cord
FEATURES	High-stability and resistance

*Standard Width Range - Megadyne will cut to desired width upon request.



MEGADYNE V-BELTS

SUPPLIED AS	Endless - Wrapped - Raw edge
LENGTH	Consult Megadyne
WIDTH	According to section
PITCH	Wrapped B, C, D; Narrow 3V, 5V, 8V; Raw edge BX, CX
TENSION MEMBER	Polyester
FEATURES	Long life and good performance



MEGADYNE V-BELTS - PLURIBAND

SUPPLIED AS	Endless
LENGTH	2540-15 250 mm
WIDTH	According to the number of V-belts
PITCH	R8V
TENSION MEMBER	Polyester
FEATURES	Oil and heat-resistant, static dissipating



MEGALINEAR	
SUPPLIED AS	Open-ended roll - Joined - PPJ
LENGTH	MEGALINEAR 0.5-100 m
STANDARD WIDTH	Up to 150 mm (200 mm on select pitches*)
PITCH	T10, AT5, AT10, AT20
TENSION MEMBER	Steel, HP, HF, HPF, Stainless Steel, Kevlar®
FEATURES	Wear resistance, strong, long life, can be joined to any length

* MEGALINEAR WIDE: T5, T10 H.

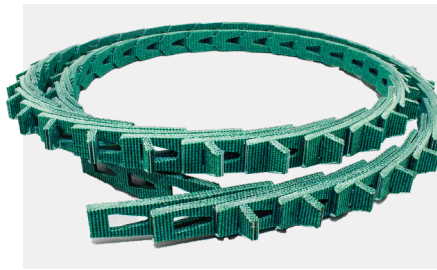

ACCU-LINK®	
SUPPLIED AS	Rolls
LENGTH	7 - 30 m
SECTIONS	Z/3L, A/4L, B/5L, C
FABRIC	Multi-layer woven polyester
FEATURES	Fast and easy installation; durability; any length possible

SPECIAL COVERS

AVAFC 60/70/85



MATERIAL	Polyurethane
COLOUR	Transparent
Excellent cut and wear-resistance and good oil-resistance.	

DURATAQ™



MATERIAL	Natural Rubber
COLOUR	Orange/Red
Cover offers a proprietary custom blended rubber which has a good CoF and very good abrasion-resistance.	

SUPERGRIP PETROL

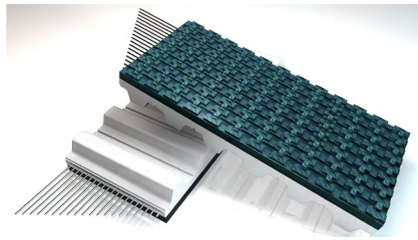

MATERIAL	PVC
COLOUR	Petrol Green
High CoF, applicable for slight height compensation, low shock-absorption capabilities. Improved adhesion even in case of moisture and dirt.	

METAL DRIVE COMPONENTS

Use an extensive range of pulleys and accessories like timing bars, flanges, clamping plates, couplings to design a complete drive transmission system.

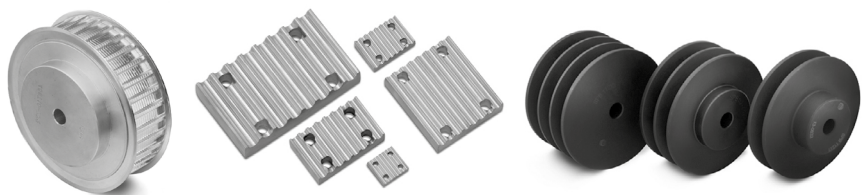

SAWING

After trees are harvested from the forest or the farm they are cut into shorter, more manageable lengths for further processing. The sawing environment, whether in the field or mill, is one of dust, dirt and lots of vibration.

Power Transmission belts used to drive the saw must be strong, rigid and wear-resistant. Megadyne offers a wide range of high strength belt options in single-V, banded-V and link-V constructions.

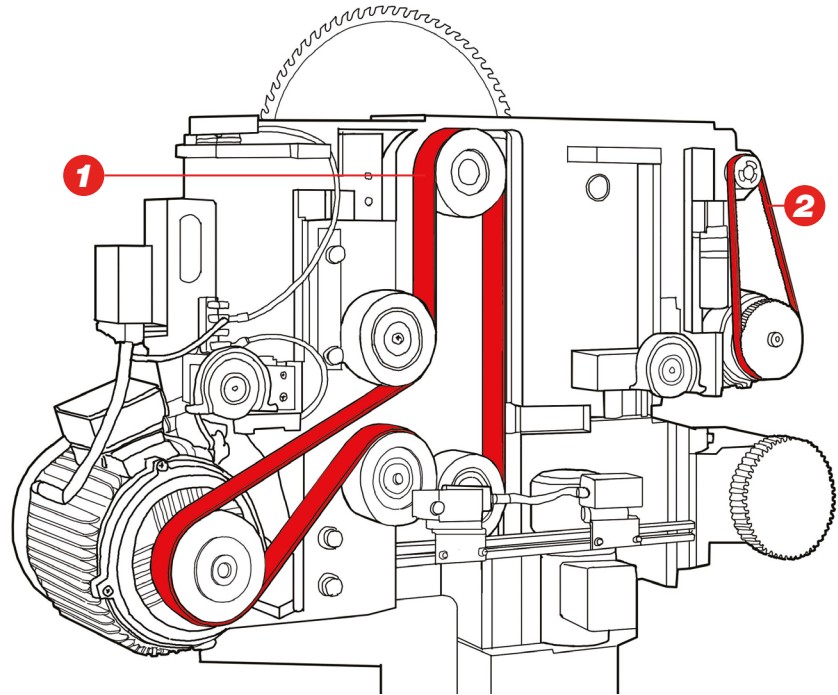

PLURIBAND

Banded version of V-belts for high loads applications.

- Dimensional stability, smooth operation
- Oil-resistant
- Antistatic



ACCU-LINK®

Link-belt, created and developed as an alternative to classical rubber V-belts, made with a polyurethane elastomer reinforced by a multi-layer woven polyester fabric.

- Easy belt assembly
- Available in sections A, B, C
- Low-vibration level



MEGASYNC™ TITANIUM

Top of the line rubber timing belts, with superior power and torque drives capacity, even in the most extreme operating conditions (TTM8, TTM14).

- Designed for use in a typical chain driven drive applications
- Compact drive package
- High-stability and resistance
- Long life cycles, cost-efficiency



LINEA GOLD

The new generation of raw edge V-belts with narrow cross-section and raw edge construction, based on a new EPDM rubber compound.

- Resistant to chemical aggressive environments, ageing, ozone, UV and heat

DEBARKING

After the tree is cut into manageable lengths, the tree is debarked. This process prepares bare wood for later processing into chips or veneer. Like Sawing, drive vibration is common along with dust and dirt. Contamination between the belt and pulley can affect belt life expectancy as belts tend to want to roll over. Additionally, drive shock loads are common in this area and can also lead to belt breakage and shortened belt life.

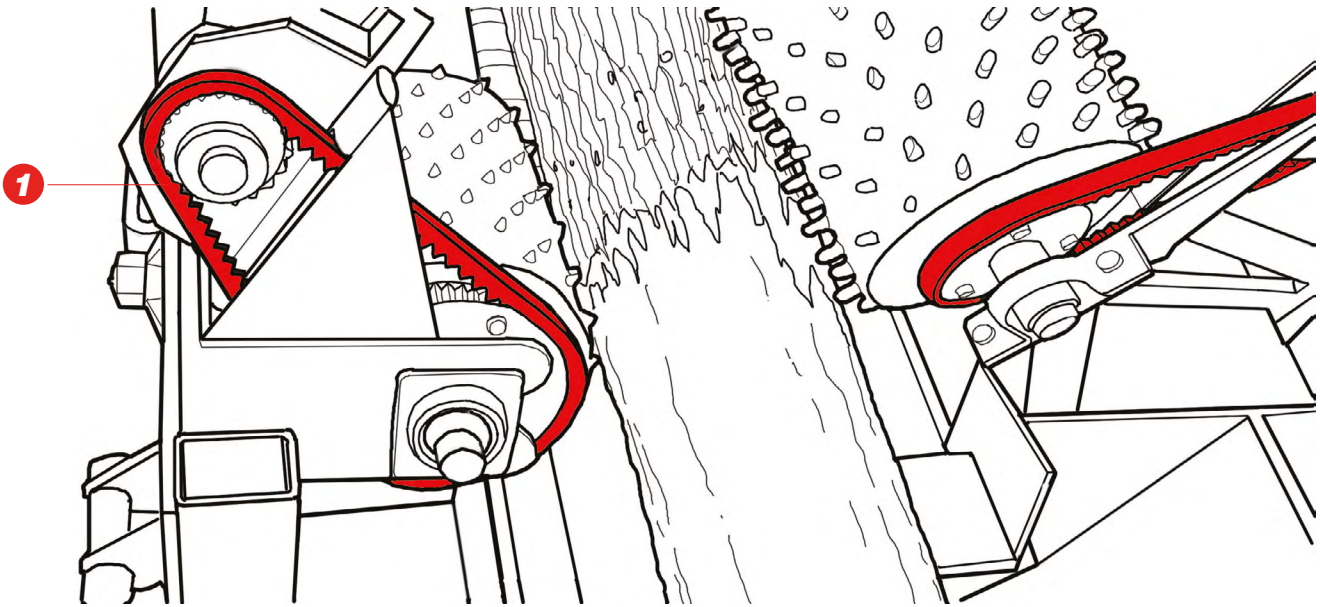

MEGASYNC™ TITANIUM

Top of the line rubber timing belts, with superior power and torque drives capacity, even in the most extreme operating conditions (TTM8, TTM14.)

- Designed for use in a typical chain driven drive applications
- Compact drive package
- High-stability and resistance
- Long life cycles, cost-efficiency



OLEOSTATIC GOLD

Top of the line in rubber wrapped V-belts; extremely wide horsepower ranges.

- Oil and heat-resistant
- Long service-life
- Low maintenance costs



PLURIBAND

Banded version of V-belts for high-loads applications.

- Dimensional stability, smooth-operation
- Oil-resistant
- Antistatic

WOOD SHREDDERS

Wood shredders are machines used for reducing wood into smaller woodchips; they come in many different types and sizes.

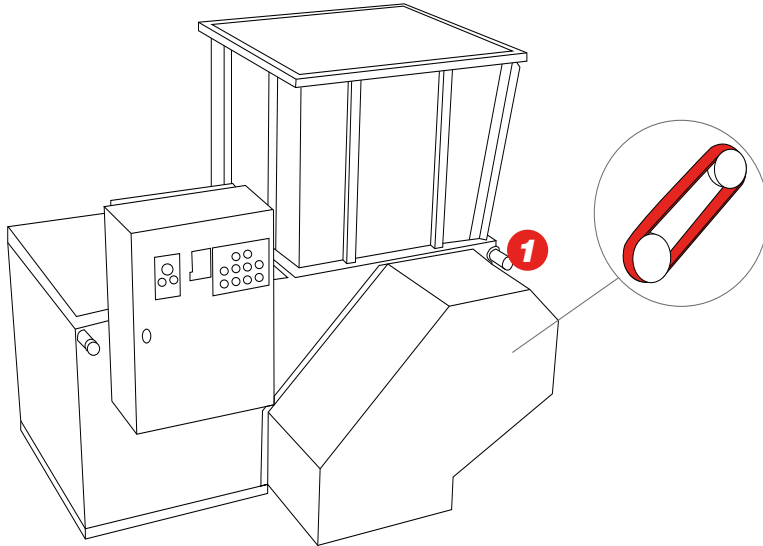

MEGASYNC™ TITANIUM

Top of the line rubber timing belts, with superior power and torque drives capacity, even in the most extreme operating conditions (TTM8, TTM14).

- Designed for use in a typical chain driven drive applications
- Compact drive package
- High-stability and resistance
- Long life cycles, cost-efficiency



OLEOSTATIC GOLD

Top of the line in rubber wrapped V-belts; extremely wide horsepower ranges.

- Oil and heat-resistant
- Long service-life

VENEER SCARFING & EXIT TRANSFER

Another by-product of the debarked log is veneer. Veneer for use in lamination of MDF (Medium Density Fiberboard) board or Veneer used in the construction of plywood. After bark is removed from the log, the clean log is moved to a veneer scarfing line. In this case the log is gripped on both ends and turned at a very high-speed against a very sharp scarfing blade. Various gauges of veneer can be scarfed; all depending on the finished material needed.

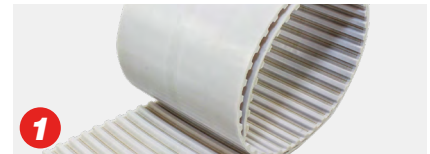
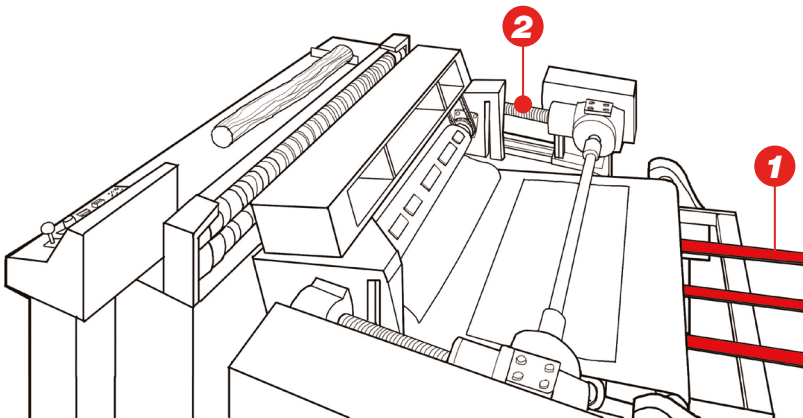

MEGALINEAR

Thermoplastic PU 92 ShA belts and S & Z parallel cord. Supplied as open-length rolls or as endless joined belts; available in various tooth profiles and cords.

- Customized with co-extruded or laminated covers
- Extra grip and wear-resistance
- High flexibility



MEGADYNE MEGASYNC™

Rubber endless timing belts made of high-quality rubber compounds and spiral fiberglass tension members.

- High power rating
- Reduced width and compact pulleys

VENEER STACKER

The Scarfed veneer is taken from the exit transport conveyor and stacked into piles for later use.

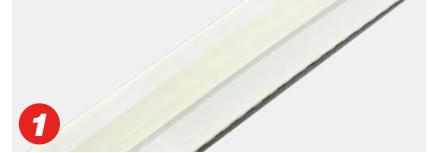
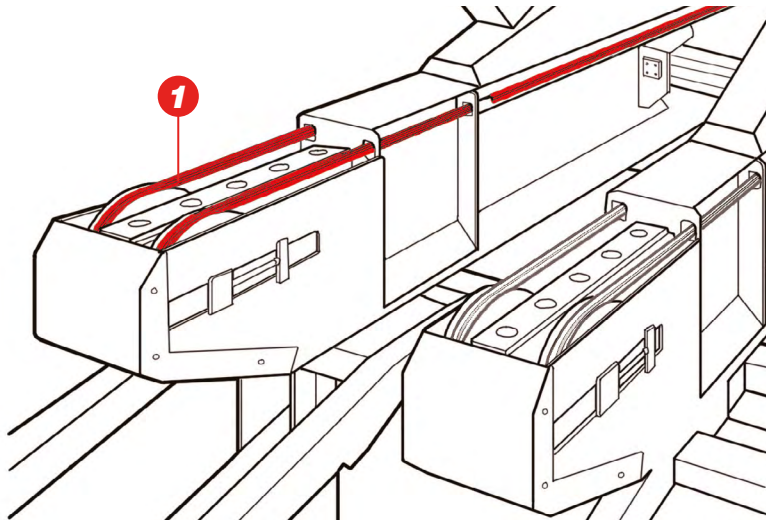

MEGALINEAR

Thermoplastic PU 92 ShA belts with S & Z parallel cords (AT10 with welded K17 guides or square profile centered on convey side of belt).

- High-precision linear positioning

PLYWOOD LAYUP & PRESSING

For plywood construction, individual sheets of veneer are selected from the stacking pile, glued and pressed to achieve the desired dimensional solid panel. MEGALINEAR timing belts are used to move veneer from veneer stacking to the press and again at press exit.



MEGALINEAR

Thermoplastic PU 92 ShA belts and S & Z parallel cord. Supplied as open length rolls or as endless joined belts; available in various tooth profiles and cords.

- Customized with co-extruded or laminated covers
- Extra-grip
- Wear-resistance
- High-flexibility

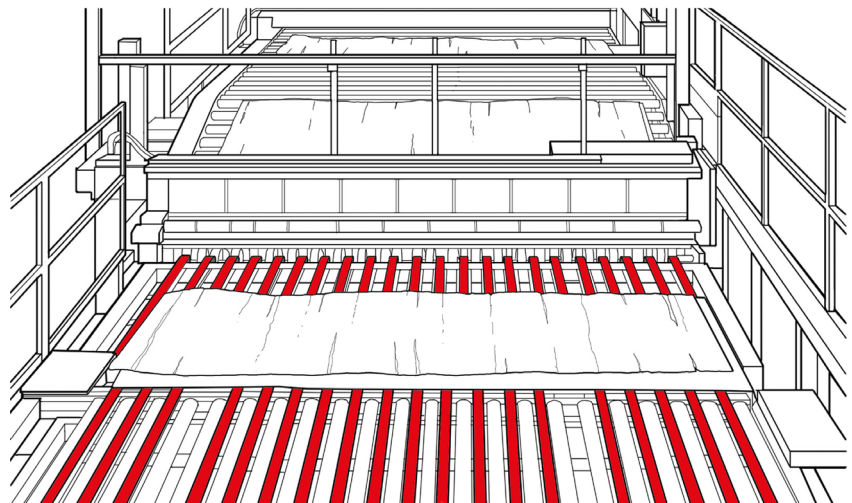

CHIPPING & MDF PREPARATION

The chipper is the first step in the manufacture of engineered board like MDF (medium density fiberboard). After the logs are debarked they are fed to a chipper where they are converted into small pieces of wood. Next is chip washing, drying and processing. Processing includes a mixture of glues, waxes and adhesives which creates a pulp like mix. This mix is then deposited onto a series of conveyor belts which ultimately are used to create the necessary matt of material to be delivered to the press.

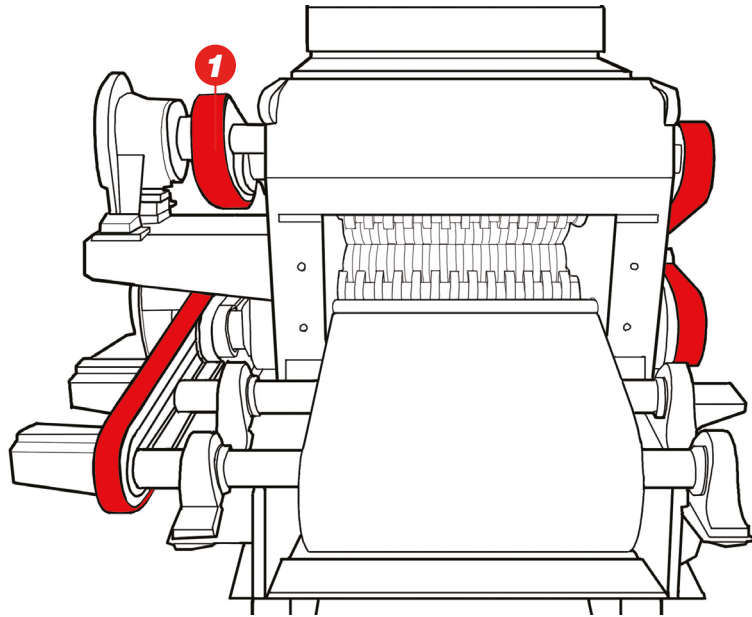

MEGASYNC™ TITANIUM

Top of the line rubber timing belts, with superior power and torque drives capacity, even in the most extreme operating conditions (TTM8, TTM14).

- Designed for use in a typical chain driven drive applications
- Compact drive package
- High-stability and resistance
- Long life cycles, cost-efficiency



PLURIBAND

Banded version of V-belts for high-loads applications.

- Dimensional stability, smooth-operation
- Oil-resistant
- Antistatic

PRESS EXIT, TRIMMING & INSPECTION

After plywood panels are pressed and MDF boards are formed, timing belts are commonly used to move the wide panels to trimming and final inspection.

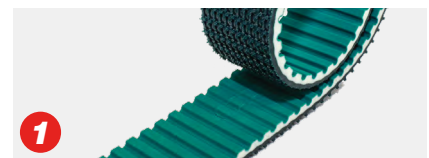
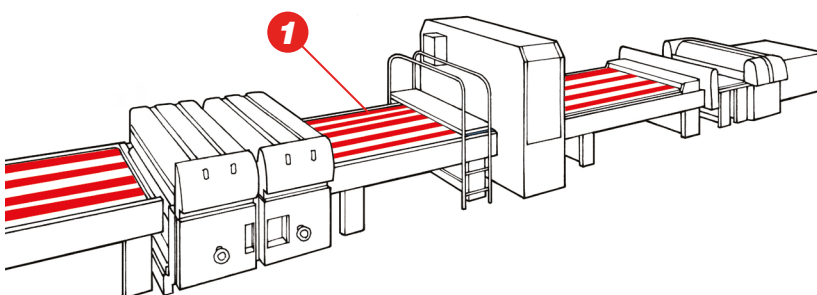

MEGALINEAR

Thermoplastic PU 92 ShA belts with S & Z parallel cords. Supplied as open length rolls or as endless joined belts; available in various tooth profiles and cords.

- Customized with co-extruded or laminated covers
- Extra-grip
- Wear-resistance
- High-flexibility
- Maintenance-free



CASE STUDY

APPLICATION: Wood Panel Conveyor

PREVIOUS BELT: Wide non-synchronous conveyor belt

PREVIOUS BELT PROBLEMS: Wide boards would skew as the boards were being moved into edge trimming

MEGADYNE SOLUTION: MEGALINEAR AT10 WITH NFT

Megadyne MEGALINEAR AT10 with NFT, moving in a precision indexed fashion eliminated skewing. Additionally the load of the boards spread across 4 MEGALINEAR belts enabled the use of PPJ for easy belt installation and belt replacement.

CERTIFICATIONS



All Megadyne polyurethane power transmission belts comply with ISO 14001, ISO 9001 and European RoHS Directive. The belts are made with raw materials in compliance with REACH standards, meaning that all belts, pulleys, toothed bars, couplings blocking units and other items supplied by Megadyne do not contain one (or several) of the SVHC in Candidate List above a concentration of 0.1% w/w.

All Megadyne rubber power transmission belts are made in accordance with the Quality Management System Standard: ISO 9001 and ISO 14001. These certificates are valid for the following field of application: design, manufacture and sale of power transmission belts. Marketing of transmission and transport elements (pulleys, tensiometers).

ABOUT SUSTAINABILITY

Sustainability has always been a guiding principle for Ammega and all members of Ammega Group. We are proud to work with **EcoVadis** to monitor and evaluate our environmental, social, and ethical performance.

At Megadyne, we are committed to becoming more and more responsible towards the world by reducing our impact on the planet. We work on new technological raw materials made by partners using the most ecological sustainable technologies. Our team has been working on the continuous improvement of products, services, and solutions for the benefit of society and the environment. Our vision is to be the local partner of choice for sustainable belting solutions around the globe.

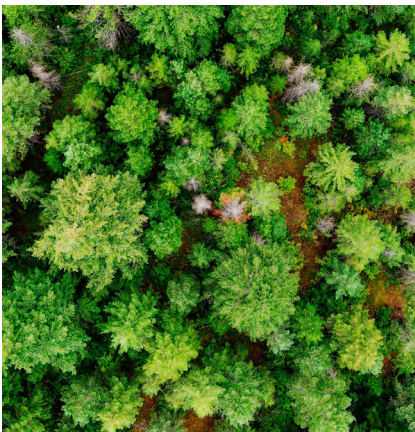

Discover Your Local Contacts

The local partner of choice
for sustainable power transmission belting solutions
around the globe.



General contact information:

Megadyne

Via Trieste, 16
Via S. Lucia 114 - 10075 Mathi (Torino)
Italy



Scan the QR code
and find your local
contact

