



PAPER AND PRINT

INDUSTRY
BROCHURE

EN

PAPER AND PRINT

The paper and print industry encompasses numerous intricate manufacturing and finishing processes, each placing stringent requirements on machinery. Throughout the entire production chain, drive systems must excel in precision, durability, reliability, and optimal power transmission. Megadyne belts offer high-performance solutions that effectively meet these demanding criteria.

Megadyne has been catering to your needs since 1957, designing and manufacturing power transmission belts, matched components, and complete belt systems for all types of equipment. We are a reliable partner for original equipment manufacturers and aftermarket distributors, with:

8 manufacturing plants in Europe, North America, and Asia, more than 170 Customer Solution Centres and 3 main distribution hubs around the world, able to deliver products efficiently, from large industrial sites to remote locations.

BELT PROPERTIES



MEGADYNE MEGASYNC™ RUBBER ENDLESS TIMING BELTS

SUPPLIED AS	Endless
LENGTH	248 - 4 956 mm
WIDTH	12 - 170 mm*
PITCH	SLV3 8M, SLV3 14M, GLD2 8M, GLD2 14M, TTM8, TTM14, RPP8 - RPP14
TENSION MEMBER	Fiberglass and Carbon fiber
FEATURES	High-stability and resistance, antistatic

*Standard Width Range - Megadyne will cut to desired width upon request.



MEGADYNE POLYURETHANE TIMING BELTS

SUPPLIED AS	Open-ended roll - Endless - Joined - PPJ
LENGTH	MEGALINEAR 0,5 - 100 m / MEGAFLEX 1,5 - 22,60 m MEGAPOWER 225 - 2 250 mm
WIDTH	MEGALINEAR / MEGAFLEX 12 - 150 mm MEGAPOWER 6 - 75 mm
PITCH	T5, T10, AT5, AT10, AT20, H, RPP14 XHP, QST8, QST14
TENSION MEMBER	Steel - HP - HF - HPP - Stainless Steel - Kevlar®
FEATURES	High-resistance belts available in different lengths

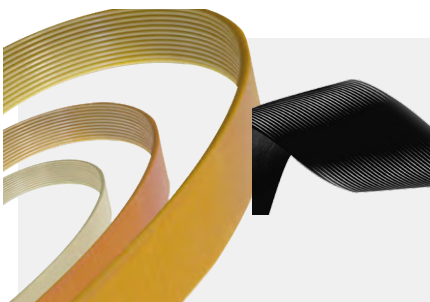

MEGADYNE PV RIBBED BELTS

SUPPLIED AS	Endless
LENGTH	PH 584 - 1 975 mm; PJ 350 - 2 489 mm; PK 588 - 2 555 mm
WIDTH	Consult Megadyne
PITCH	PH, PJ, PK
TENSION MEMBER	Polyester
FEATURES	Long life and good performance



MEGADYNE V-BELTS

SUPPLIED AS	Endless
LENGTH	Consult Megadyne
WIDTH	According to section
PITCH	Wrapped A, B; Raw edge AX, BX, Raw edge XPZ, XPA, XPB, XPC
TENSION MEMBER	Polyester
FEATURES	Long life and good performance



MEGADYNE MEGALINEAR FLAT BELT	
SUPPLIED AS	Open-ended roll
LENGTH	100 m
WIDTH	16 - 30 mm
PITCH	P2, P3
TENSION MEMBER	Standard steel - HP steel - Kevlar®
FEATURES	Smooth-running, high-stability

SPECIAL COVERS

AVAFC 60/70/85



MATERIAL	Polyurethane
COLOUR	Transparent
Excellent cut and wear-resistance and good oil-resistance.	

SILICONE



MATERIAL	Silicone
COLOUR	White/Beige/Black/Transparent/Blue/Red
Cover offers a good CoF and very good abrasion-resistance.	

LINATEX™ RED



MATERIAL	Natural Rubber
COLOUR	Red
Cover offers high CoF, good wear resistance, good for wet conditions.	

NFB/NFT

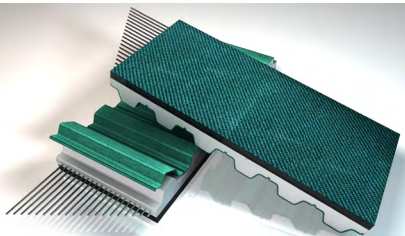

MATERIAL	Nylon Fabric
COLOUR	Green
NFT/NFB offers low friction for accumulation as well as low-noise benefits and is usually applied coextrusion on base belts.	

YELLOW GUM R14



MATERIAL	Natural Rubber
COLOUR	Yellow
Cover offers high CoF, very good wear resistance. Compound commonly used in indexing, corrugating, positioning and packaging applications. Only available on rubber base belts.	

RED GRIP

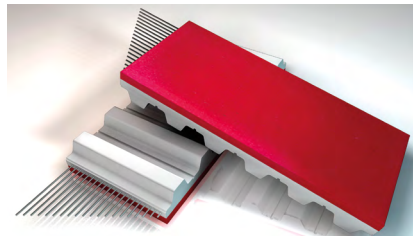

MATERIAL	PU/Synthetic Rubber
COLOUR	Red
A seamless alternative to LINATEX™. Only available on MEGALINEAR and MEGAFLEX.	

METAL DRIVE COMPONENTS

Use an extensive range of pulleys and accessories like timing bars, flanges, clamping plates, couplings to design a complete drive transmission system.

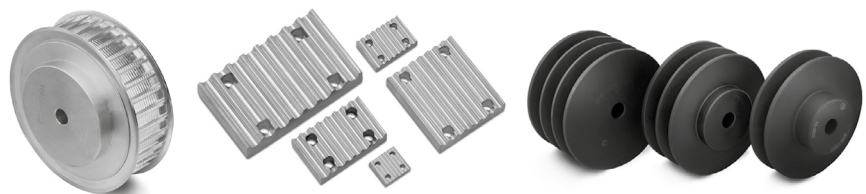

SLITTER REWINDER

Slitting rewinders are essential to cut large rolls of material into narrower rolls. Power transmission belts play a crucial role in ensuring the efficient and accurate movement of components within the machine.

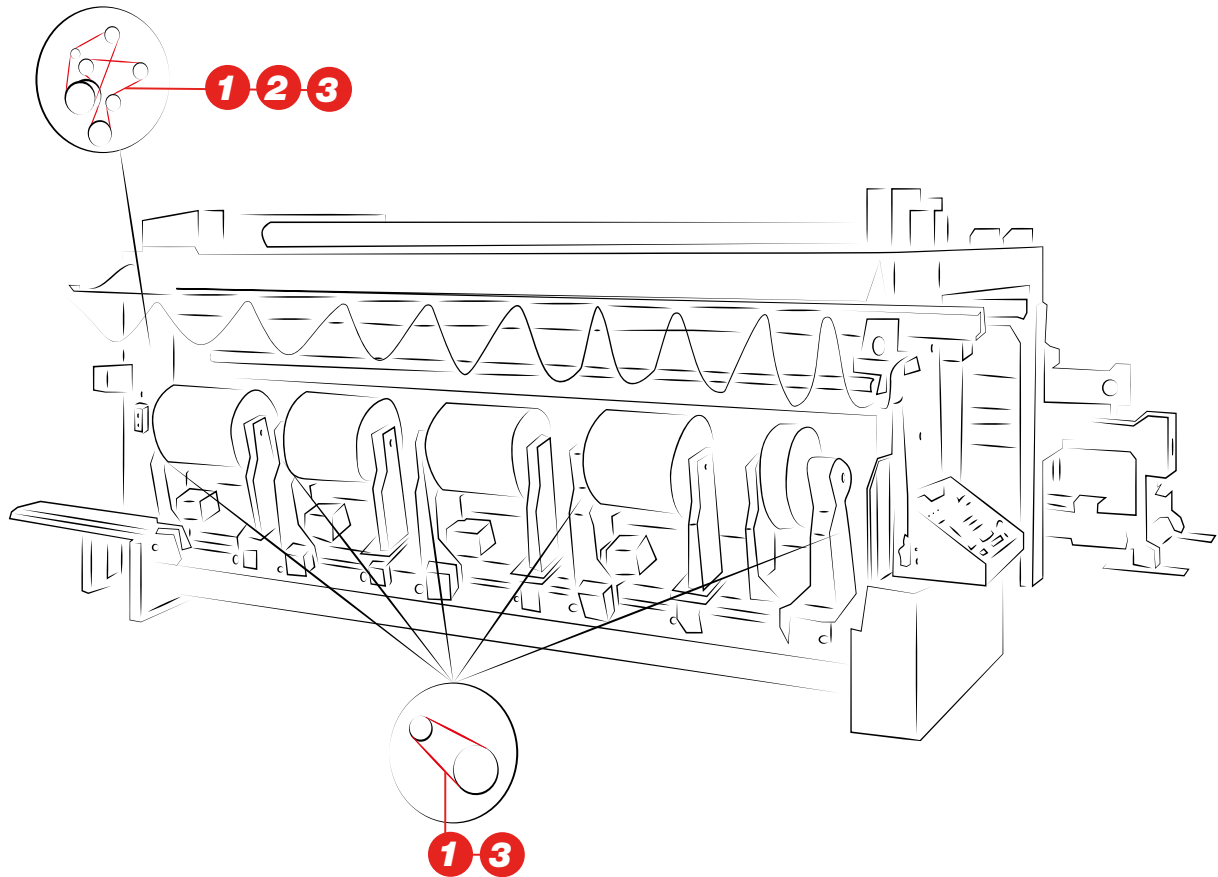

1 MEGADYNE MEGASYNC™ RUBBER ENDLESS TIMING BELTS

Rubber endless timing belts made of high-quality rubber compounds and spiral fiberglass tension members.

- Moulded rubber belts available in multiple lengths
- Suitable for high power transmission drives



2 MEGAFLEX

Truly endless timing or flat belts with thermoplastic polyurethane and high-strength helically wound zinc coated steel tension members.

- Low-elongation and high-stability
- Low-friction and power absorption
- Suitable for heavy-loads
- High-resistance to fatigue



3 MEGAPOWER

Thermoset polyurethane 88 ShA with superior wear and abrasion resistance. MEGAPOWER offers good running characteristics and is especially suited for power transmission.

- Low noise
- Excellent dimensional stability
- High performance in terms of flexibility and traction resistance

PRINTING MACHINE

Industrial printing machines are large-scale systems designed for the mass production of printed materials, from newspapers to packaging. Power transmission belts ensure precise colour reproduction and superior quality control, catering to a wide range of industries, including publishing, advertising, and manufacturing.

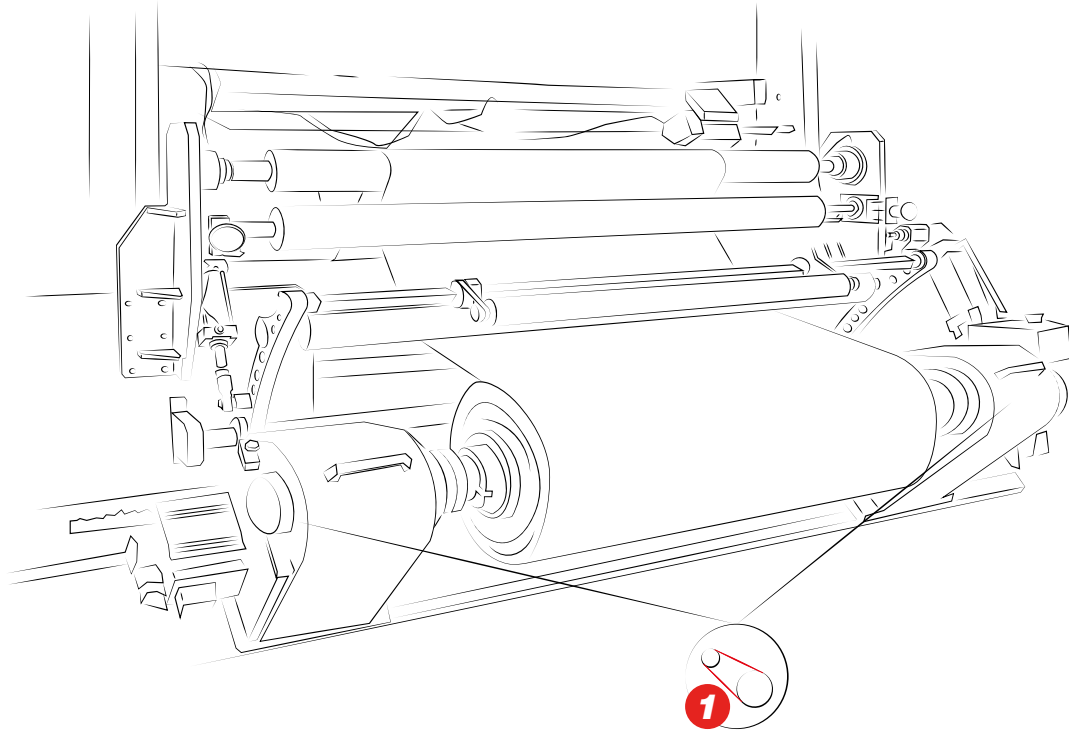

MEGADYNE MEGASYNC™

Rubber Endless timing belts made of high-quality rubber compounds and spiral fiberglass tension members.

- Moulded rubber belts available in multiple lengths
- Suitable for high power transmission drives



SPECIAL RUBBER BELTS

Rubber timing belts made of high-quality rubber compounds, and high performance tension members.

- Supplied with high-friction non-marking homogenous cover

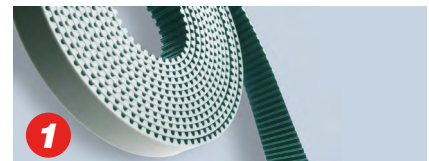

SPECIAL POLYURETHANE BELT

Thermoplastic PU 92 ShA belts, supplied as open-length rolls or as endless joined belts; available in various tooth designs and cords.

- Supplied with high friction non-marking homogenous cover

IN-LINE FLEXOPRINTING MACHINE

Flexography is a high-speed printing process commonly used for printing high volumes of labels. Power transmission belts are essential for transferring power from the motor to components such as rollers, cylinders, and printing units.



1 MEGADYNE MEGASYNC™ RUBBER ENDLESS TIMING BELTS

Rubber endless timing belts made of high-quality rubber compounds, and high-performance tension members.

- Molded to length and pitch designation
- High-performance
- Low-noise



2 V-BELT

Wrapped V-belts, made of polybutadiene compound in a wide variety of sizes and sections (B, C, D, 3V, 5V, 8V).

- Oil and heat-resistant
- Long and reliable service-life
- Reduced operational cost

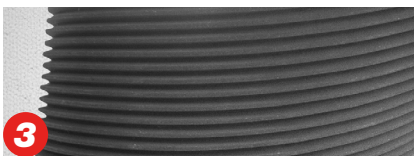

3 PV RUBBER RIBBED BELTS

Endless belts with longitudinal V-shaped grooves which combine the benefits of flat belts and V-belts. Supplied with standard or elastic cords, on request.

- High-flexibility
- Improved power-performance by increasing the number of ribs

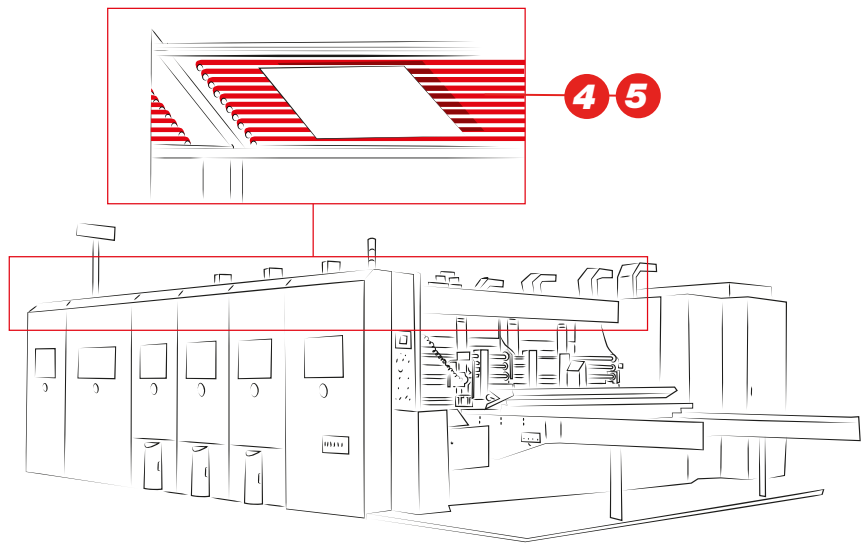

IN LINE FLEXOPRINTING - SHEETFED PRESS

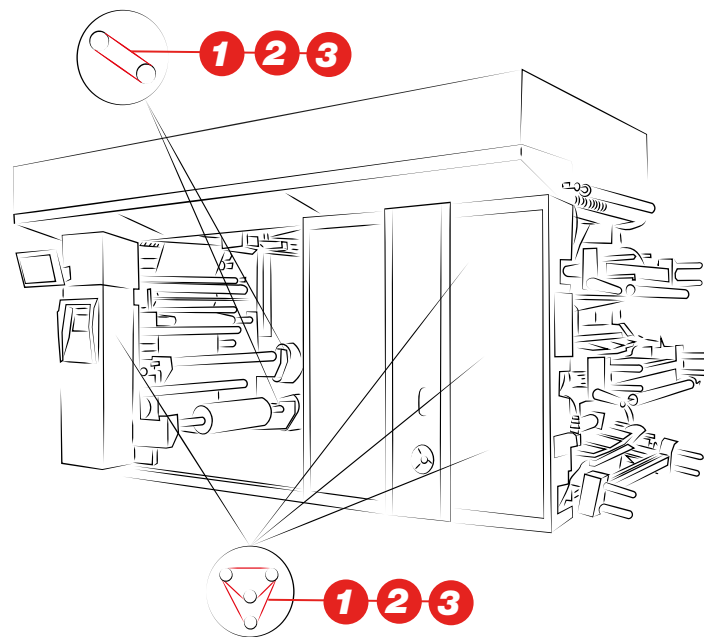

STACKPRESS FLEXO PRINTING - WEB-FED



4 SPECIAL RUBBER BELTS

Rubber timing belts made of high-quality rubber compounds, and high performance tension members.

- Supplied with high-friction non-marking homogenous cover

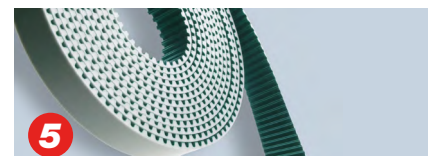

5 SPECIAL POLYURETHANE BELT

Thermoplastic PU 92 ShA belts, supplied as open-length rolls or as endless joined belts; available in various tooth designs and cords.

- Supplied with high friction non-marking homogenous cover

CI-FLEXOPRINTING MACHINE

This specialised printing machine is renowned for its high output capacity and superior print quality on a variety of substrates, ensuring precise and efficient printing. Power transmission belts are commonly used as main drive and tension control systems.

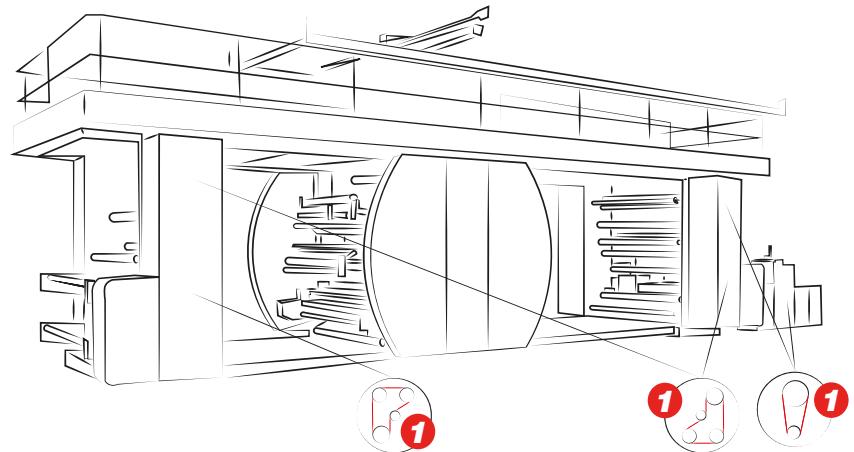

MEGADYNE MEGASYNC™

Rubber endless timing belts made of high-quality rubber compounds, and high-performance tension members.

- Moulded to length and pitch designation
- High-performance
- Low-noise



V-BELT

Wrapped V-belts, made of polybutadiene compound in a wide variety of sizes and sections (B, C, D, 3V, 5V, 8V).

- Oil and heat-resistant
- Long and reliable service-life
- Reduced operational cost

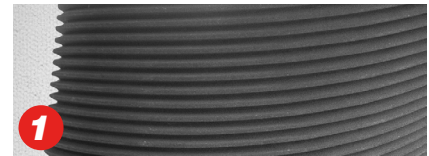

PV RUBBER RIBBED BELTS

Endless belts with longitudinal V-shaped grooves which combine the benefits of flat belts and V-belts. Supplied with standard or elastic cords, on request.

- High-flexibility
- Improved power-performance by increasing the number of ribs

ROTOGRAVURE PRINTING MACHINES

Rotogravure is an intaglio printing process commonly used in commercial printing and packaging when large print run and volume are needed. Power transmission belts drive rollers and cylinders, ensuring smooth operation with their durability, flexibility, and efficiency.

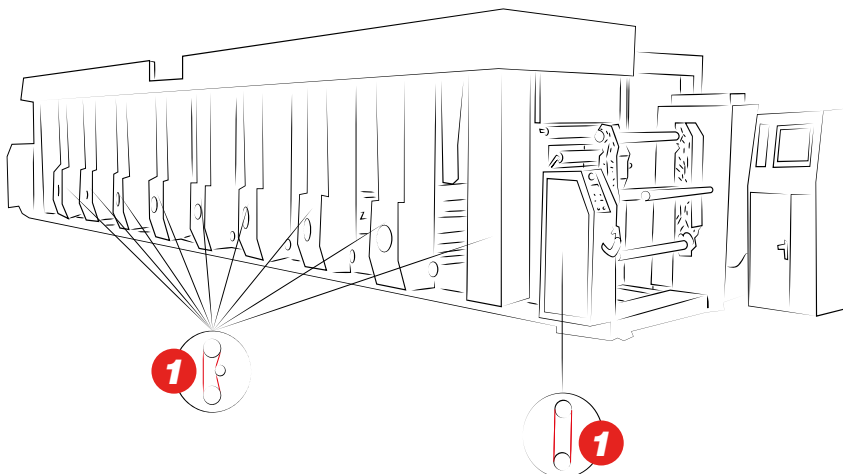

MEGADYNE MEGASYNC™ RUBBER ENDLESS TIMING BELTS

Rubber endless timing belts made of high-quality rubber compounds, and high-performance tension members.

- Moulded to length and pitch designation
- High-performance
- Low-noise

OFFSET PRINTING

Offset printing is a method of mass-production printing in which the ink is directly transferred (or “offset”) from a printing plate to a rubber blanket cylinder, and then from the blanket to the final substrate, such as paper. Power transmission belts are commonly used to ensure smooth and precise operations. Key areas include: impression cylinder, inking system, plate cylinder, paper feeding.

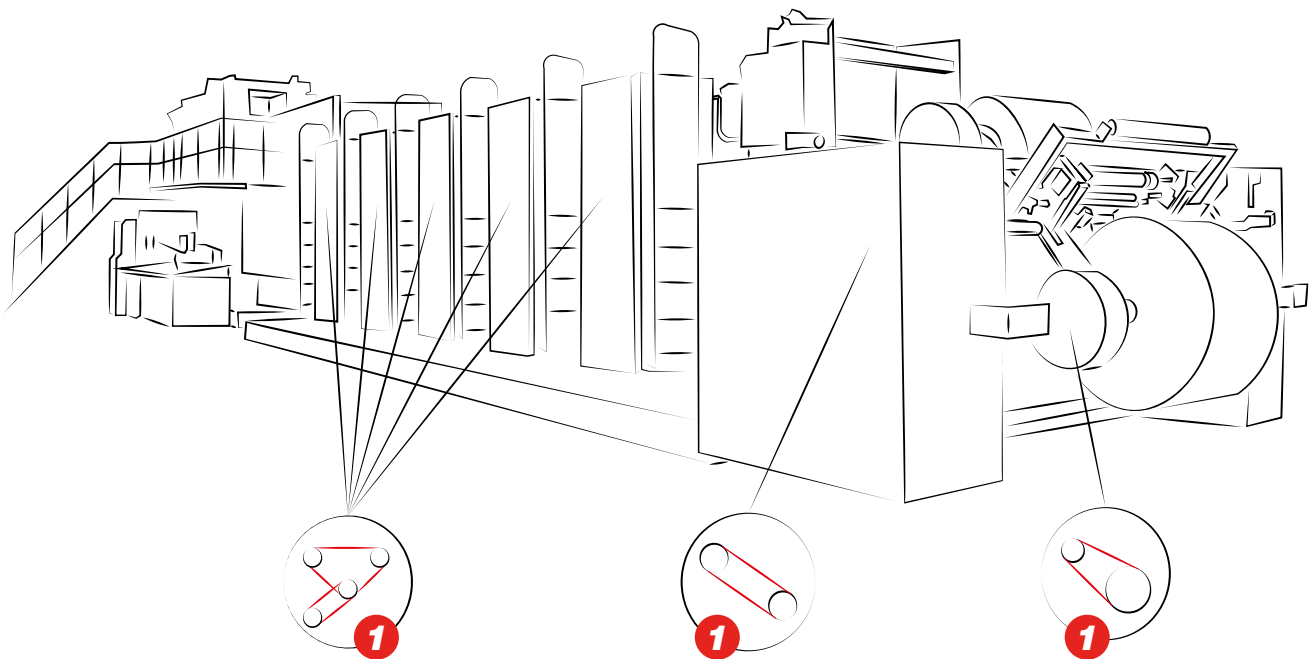

MEGADYNE MEGASYNC™

Rubber endless timing belts made of high-quality rubber compounds, and high-performance tension members.

- Moulded to length and pitch designation
- High-performance
- Low-noise



MEGALINEAR

Thermoplastic polyurethane and S&Z parallel cord, supplied as endless joined belts and available in any length.

- Suitable for high-speed conveying
- High-resistance to fatigue



SPECIAL POLYURETHANE BELT

Thermoplastic PU 92 ShA belts, supplied as open length rolls; available in various tooth designs and cords

- High-friction
- Non-marking homogenous cover

DIGITAL PRINTING MACHINE

Digital printing machines use ink droplets to transfer images onto surfaces, offering a cost-effective solution for print-on-demand services. Power transmission belts ensure efficient, quiet operation of the paper feed, transport system, printhead carriage, media handling, and drying system.

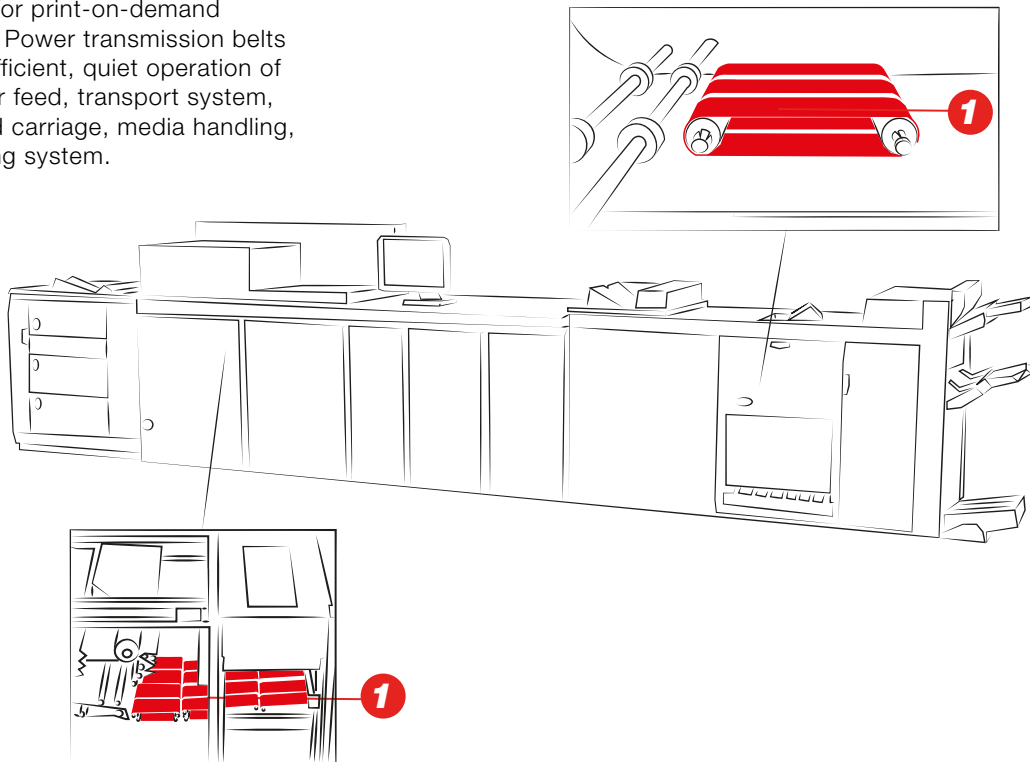

MEGADYNE MEGASYNC™

Rubber endless timing belts made of high-quality rubber compounds, and high-performance tension members.

- Moulded to length and pitch designation
- High-performance
- Low-noise



MEGAPOWER

MEGAPOWER offers good running characteristics and is especially suited for power transmission.

- Low noise
- Excellent dimensional stability
- High performance in terms of flexibility and traction resistance

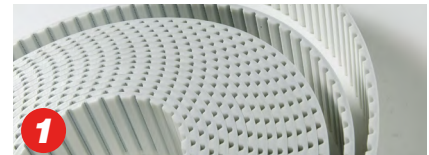

MEGALINEAR

Thermoplastic PU 92 ShA belts and S & Z parallel cord. Supplied as open-length rolls or as endless joined belts; available in various tooth profiles and cords.

- Customised solution
- High wear-resistance
- High-flexibility
- Maintenance-free



MEGAFLAT

Truly endless PU belts mandrel moulded without a single seam or splice; available in unsupported, knitted and woven structures.

- High-flexibility
- High-speed
- Energy efficiency
- Low noise and vibration



SPECIAL RUBBER BELTS

Rubber timing belts made of high-quality rubber compounds, and high performance tension members.

- Supplied with high-friction non-marking homogenous cover



SPECIAL POLYURETHANE BELT

Thermoplastic PU 92 ShA belts, supplied as open length rolls; available in various tooth designs and cords

- High-friction
- Non-marking homogenous cover

DIE CUTTING

Die cutting enables precise shaping of paper and cardboard. Power transmission belts ensure accurate movement of components in rotary and flatbed die-cutting machines, including feed, cutting, tension control, and registration systems.

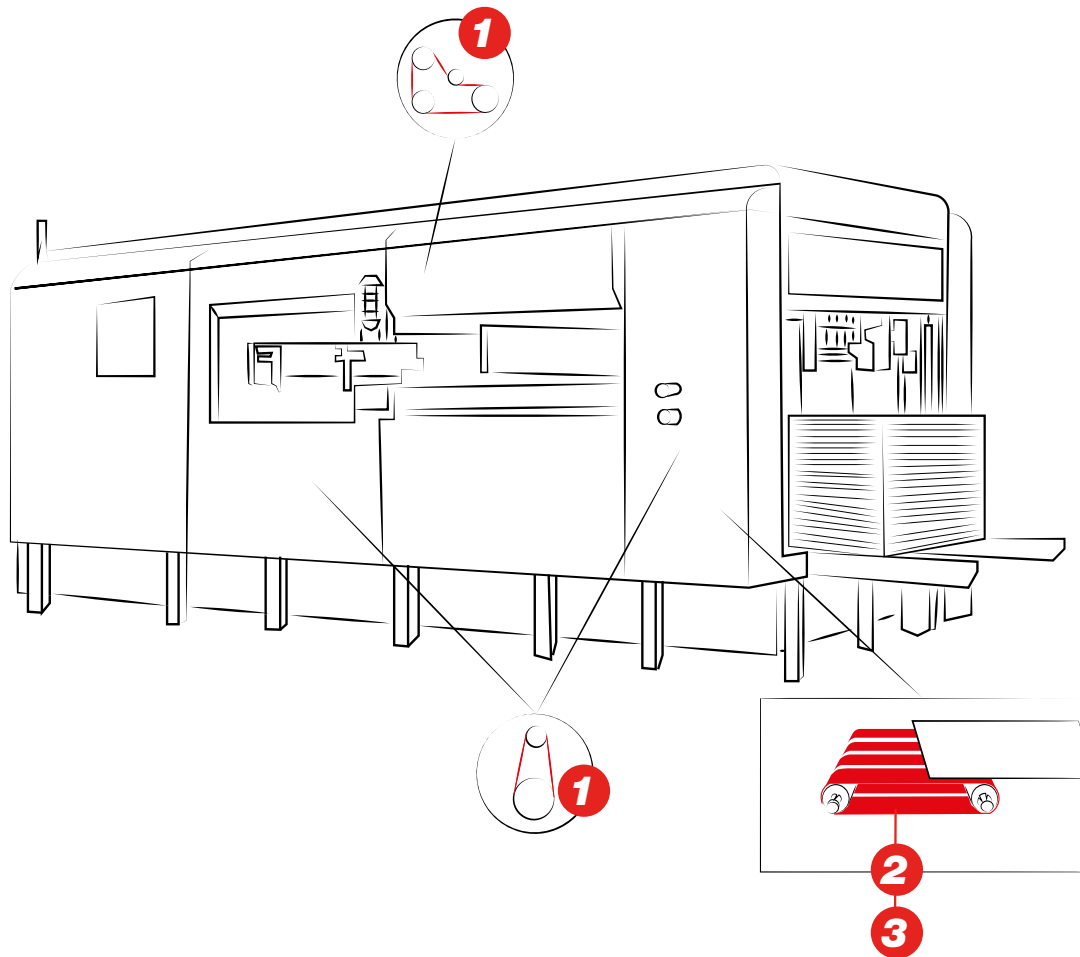

MEGADYNE MEGASYNC™

Rubber endless timing belts made of high-quality rubber compounds, and high-performance tension members.

- Moulded to length and pitch designation
- High-performance
- Low-noise

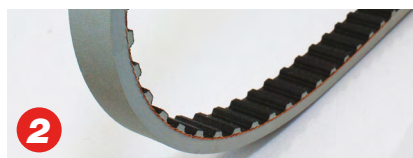

SPECIAL RUBBER BELTS

Rubber timing belts made of high-quality rubber compounds, and high performance tension members.

- Supplied with high-friction non-marking homogenous cover



SPECIAL POLYURETHANE TIMING BELTS

Thermoplastic PU belts, supplied as open length rolls or as endless jointed belts; available in various tooth designs and grades of steel cord.

- High-friction
- Non-marking homogenous cover

COATING LAMINATING

Coating and lamination are material techniques used to apply cover surfaces such as varnish, polymer, or bonds a plastic film to the substrate, to enhance surface properties like gloss, protection, or printability. Power transmission belts are essential for the smooth and efficient operation of machine components.



MEGADYNE MEGASYNC™

Rubber endless timing belts made of high-quality rubber compounds, and high-performance tension members.

- Moulded to length and pitch designation
- High-performance
- Low-noise

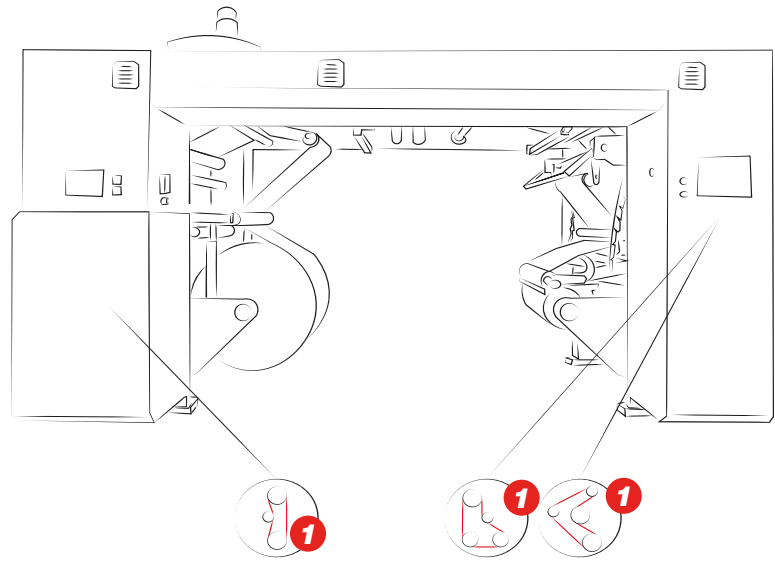

HOT FOIL STAMPING

Hot foil stamping is a printing process that transfers metal foils or pre-dried inks onto a surface. Power transmission belts facilitate the precise movement and coordination of components involved in the stamping process.

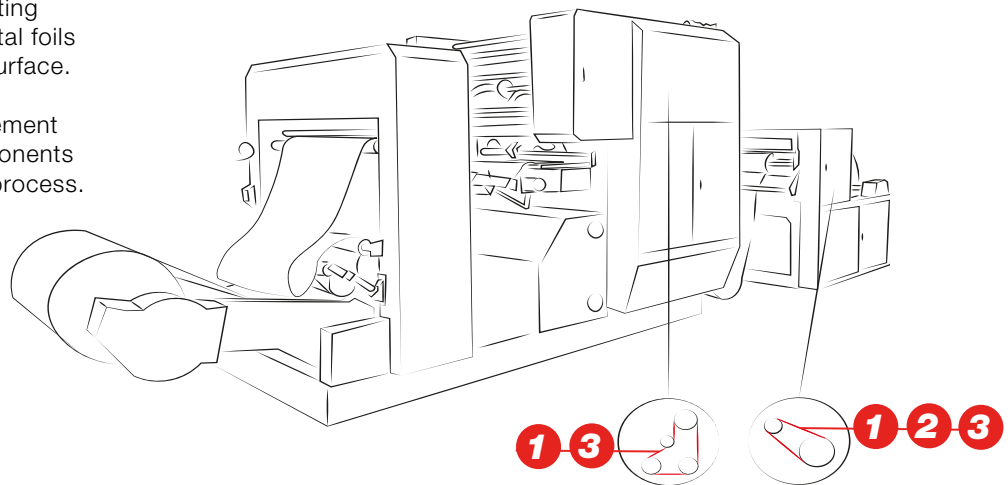

MEGADYNE MEGASYNC™

Rubber endless timing belts made of high-quality rubber compounds, and high-performance tension members.

- Moulded to length and pitch designation
- High-performance
- Low-noise

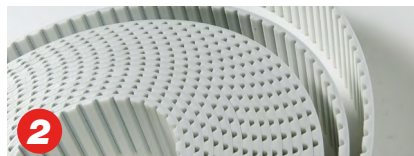

MEGALINEAR

Thermoplastic PU 92 ShA belts and S & Z parallel cord. Supplied as open-length rolls or as endless joined belts; available in various tooth profiles and cords.

- Customised solution
- High wear-resistance
- High-flexibility
- Maintenance-free



MEGAPOWER

Thermoset polyurethane 88 ShA offers superior wear and abrasion resistance. MEGAPOWER belts provide excellent running characteristics, making them ideal for power transmission.

- Low noise
- Excellent dimensional stability
- High performance in terms of flexibility and traction resistance

SHEETER

Sheeters cut materials to specific dimensions for further processing. Power transmission belts are commonly used in drive systems, as well as in feeding, cutting, and stacking mechanisms.

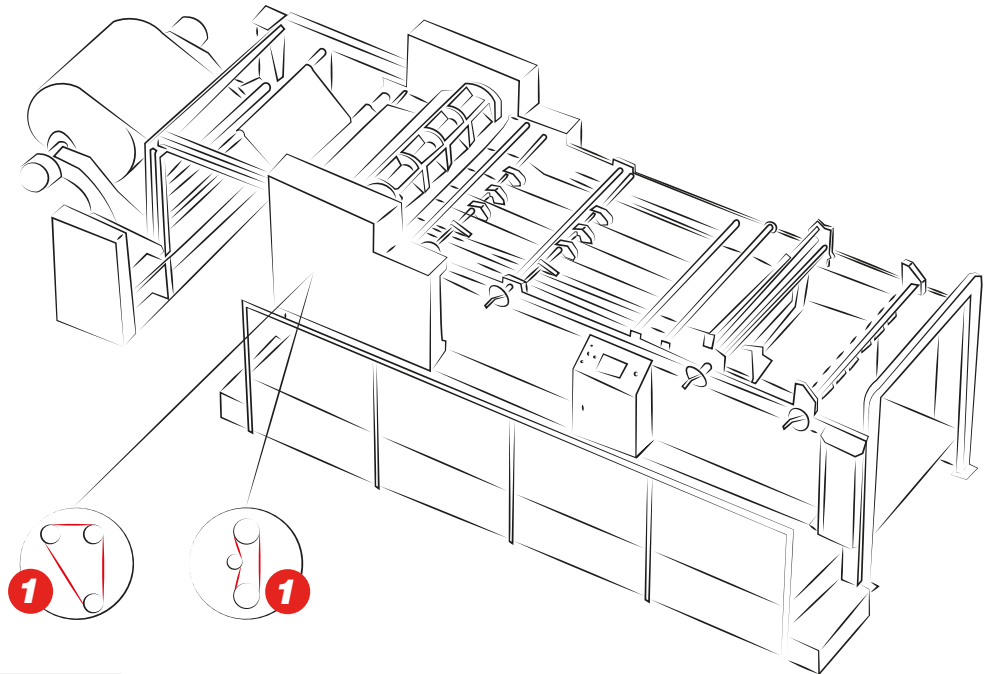

MEGADYNE MEGASYNC™ RUBBER ENDLESS TIMING BELTS

Rubber endless timing belts made of high-quality rubber compounds, and high-performance tension members.

- Moulded to length and pitch designation
- High-performance
- Low-noise

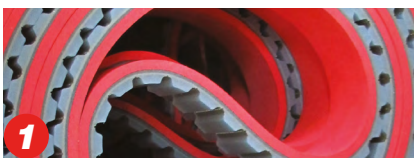

SPECIAL POLYURETHANE BELTS

Polyurethane moulded/laminated or joined belts with backing materials according to application demands.

- Non-marking
- High-friction even in high-speed conveying

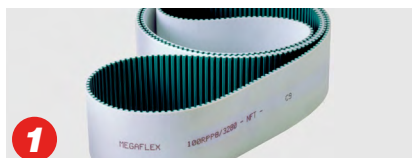

POLYURETHANE TIMING BELTS

Thermoplastic PU belts, supplied as open-length rolls or as endless joined belts; available in various tooth designs and grades of steel cord.

- High-positioning precision suitable for linear movement and lifting systems



MEGAPOWER

Thermoset polyurethane 88 ShA offers superior wear and abrasion resistance. MEGAPOWER belts provide excellent running characteristics, making them ideal for power transmission.

- Low noise
- Excellent dimensional stability
- High performance in terms of flexibility and traction resistance

MAIL SORTING AND SCANNING

Mail sorters and scanners commonly use power transmission belts as part of their mechanisms for conveying and processing mail items, ensuring smooth and efficient operations.

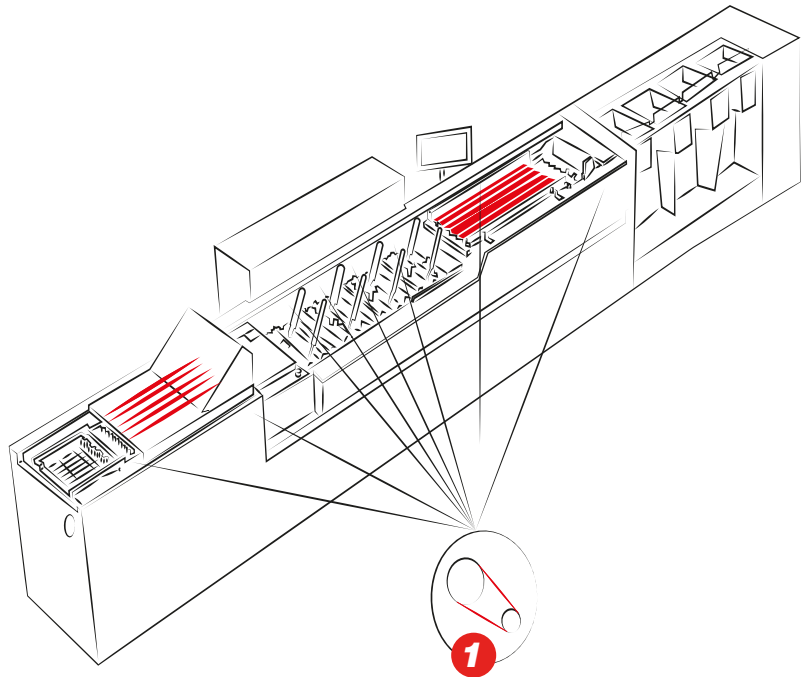

MEGADYNE MEGASYNC™ RUBBER ENDLESS TIMING BELTS

Rubber endless timing belts made of high-quality rubber compounds, and high-performance tension members.

- Moulded to length and pitch designation
- High-performance
- Low-noise



MEGAFLAT

Truly endless PU belts mandrel moulded without a single seam or splice; available in unsupported, knitted and woven structures.

- High-flexibility
- High-speed
- Energy efficiency
- Low noise and vibration

1 SPECIAL REWORKED BELTS

Truly endless moulded belts polyurethane or rubber based. Wide range of different materials, to ensure the best performances and the best match to the varied grades of film used. Grinded tooth and holes to ensure the best vacuum and grip performances.



Belts with sprayed PU foam cover

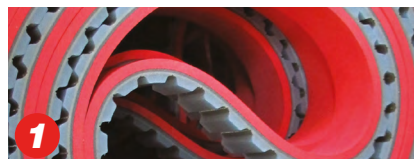

SPECIAL POLYURETHANE BELTS

Polyurethane moulded/laminated or joined belts with backing materials according to application demands.

- Non-marking
- High-friction even in high-speed conveying



Belts with anti-glaze cover



SPECIAL RUBBER FLAT BELTS

Truly endless flat rubber moulded belts equipped with special covers.

- Non-marking with high friction cover
- Smooth-running and length stability



Belts with rubber coating and vacuum holes and slots



Belts with Silicone



Belts with dual durometer polyurethane

FEEDER

Paper feeding maintains the quality of products and boosting productivity. Power transmission belts are commonly used to move paper and cardboard sheets through the feeding mechanism.

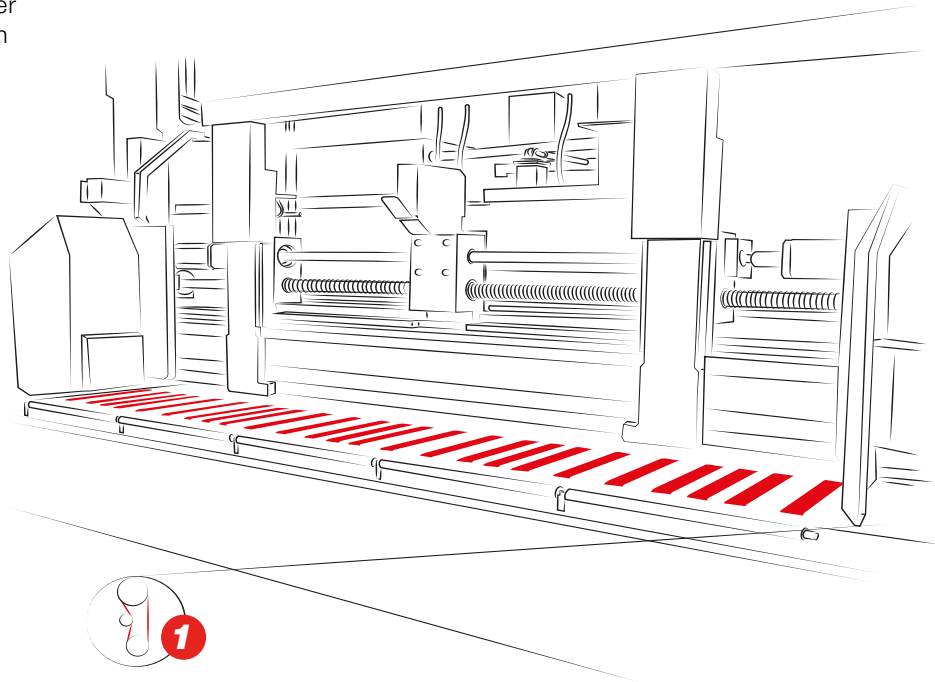

MEGADYNE MEGASYNC™ RUBBER ENDLESS TIMING BELTS

Rubber endless timing belts made of high-quality rubber compounds, and high-performance tension members.

- Moulded to length and pitch designation
- High-performance
- Low-noise

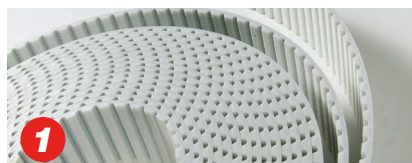

MEGALINEAR

Thermoplastic PU 92 ShA belts and S & Z parallel cord. Supplied as open-length rolls or as endless joined belts; available in various tooth profiles and cords.

- Customised solution
- High wear-resistance
- High-flexibility
- Maintenance-free



MEGAFLEX

Truly endless timing or flat belts with thermoplastic polyurethane and high-strength helically wound zinc coated steel tension members.

- Low-elongation and high-stability
- Low-friction and power absorption
- Suitable for heavy-loads
- High-resistance to fatigue



SPECIAL RUBBER ENDLESS TIMING BELTS

Truly endless rubber moulded belts equipped by special cover glued or vulcanised.

- Special shapes or slots can be moulded ground directly into the belt cover

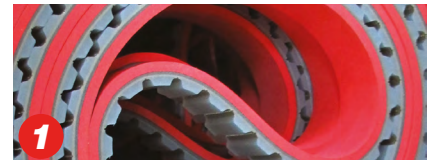

SPECIAL POLYURETHANE BELTS

Polyurethane moulded/laminated or joined belts with backing materials according to application demands.

- Non-marking
- High-friction even in high-speed conveying

DRYING MACHINE

Power transmission belts may be indirectly involved in the operation of the components that feed cardboard into and out of the dryer.

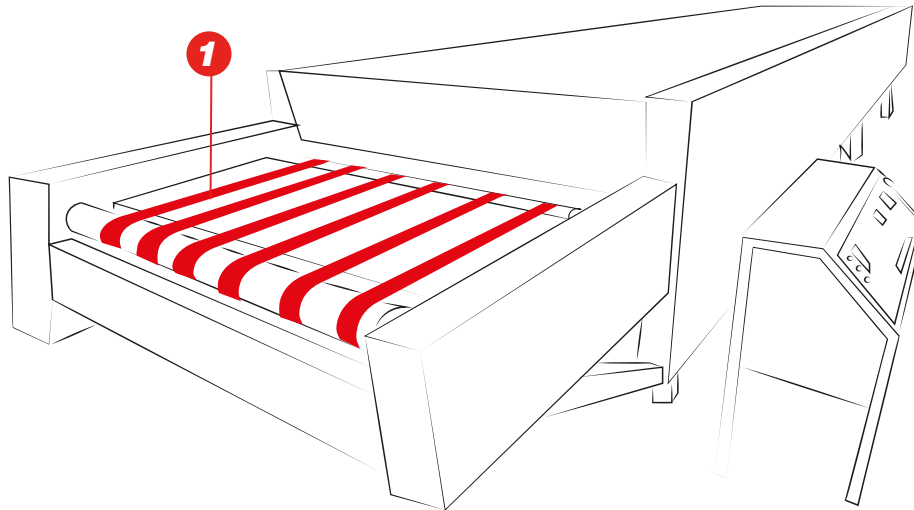

MEGADYNE MEGASYNC™

Rubber endless timing belts made of high-quality rubber compounds, and high-performance tension members.

- Moulded to length and pitch designation
- High-performance
- Low-noise

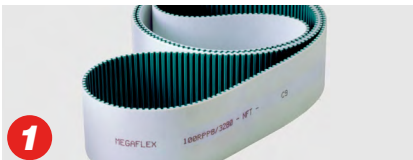

POLYURETHANE TIMING BELTS

Thermoplastic PU belts, supplied as open-length rolls or as endless joined belts; available in various tooth designs and grades of steel cord.

- High-positioning precision suitable for linear movement and lifting systems
- High-resistance to fatigue

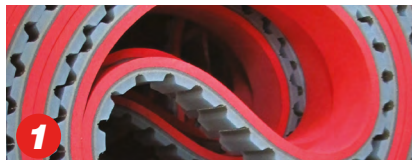

SPECIAL POLYURETHANE BELTS

Polyurethane moulded/laminated or joined belts with backing materials according to application demands.

- Non-marking
- High-friction even in high-speed conveying



SPECIAL RUBBER BELTS

Truly endless rubber moulded belts equipped by special cover glued or vulcanised.

- Special shapes or slots can be moulded or ground directly into the belt cover

BANKING ATM

A banking ATM is a self-service machine that lets users withdraw cash, check balances, and manage transactions anytime.

Rubber timing belts are favored in Automated Teller Machine for their accuracy, positioning, antistatic properties, and durability.

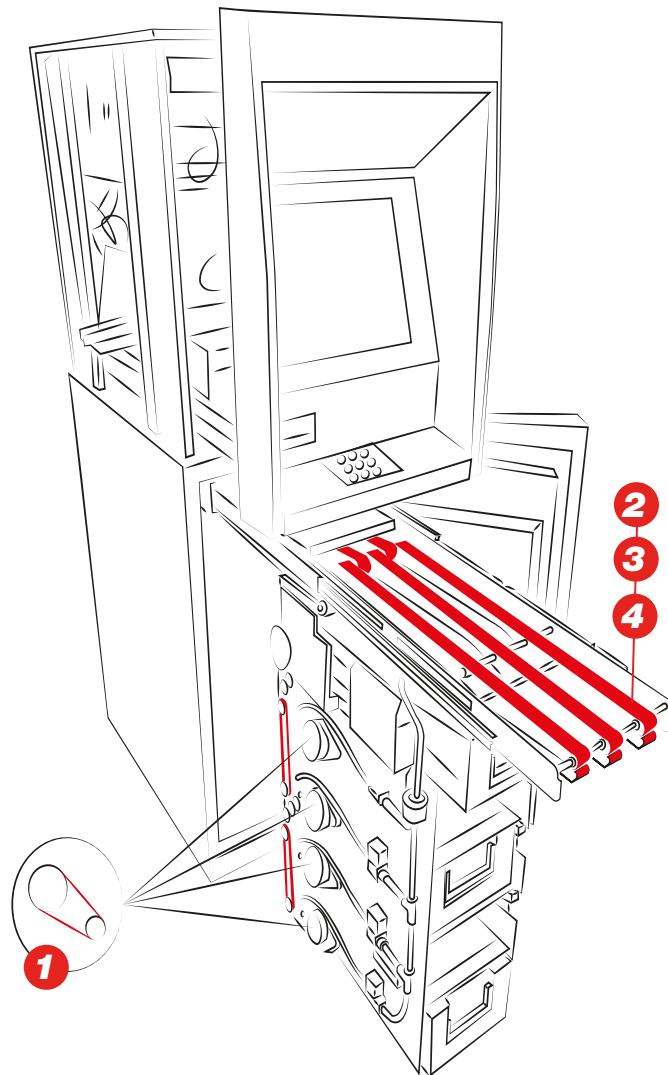

MEGADYNE MEGASYNC™

Rubber endless timing belts made of high-quality rubber compounds, and high-performance tension members.

- Moulded to length and pitch designation
- High-performance
- Low-noise



MEGAFLAT

Truly endless PU belts mandrel moulded without a single seam or splice; available in unsupported, knitted and woven structures.

- High-flexibility
- High-speed
- Energy efficiency
- Low noise and vibration



SPECIAL RUBBER FLAT BELTS

Truly endless flat rubber moulded belts equipped by special covers

- Non-marking with high friction cover
- Smooth-running and length stability



SPECIAL RUBBER ENDLESS TIMING BELTS

Truly endless rubber moulded belts equipped with special cover glued or vulcanised.

- Special shapes or slots can be moulded or ground directly into the belt cover

BINDING MACHINE

A binding machine is a machine that is used to preserve paper (or a similar material); usually to create professional documents, reports, books, journals or notepads. Power transmission belts are essential to preserve the paper during the movement and operation of the various component of the machine.

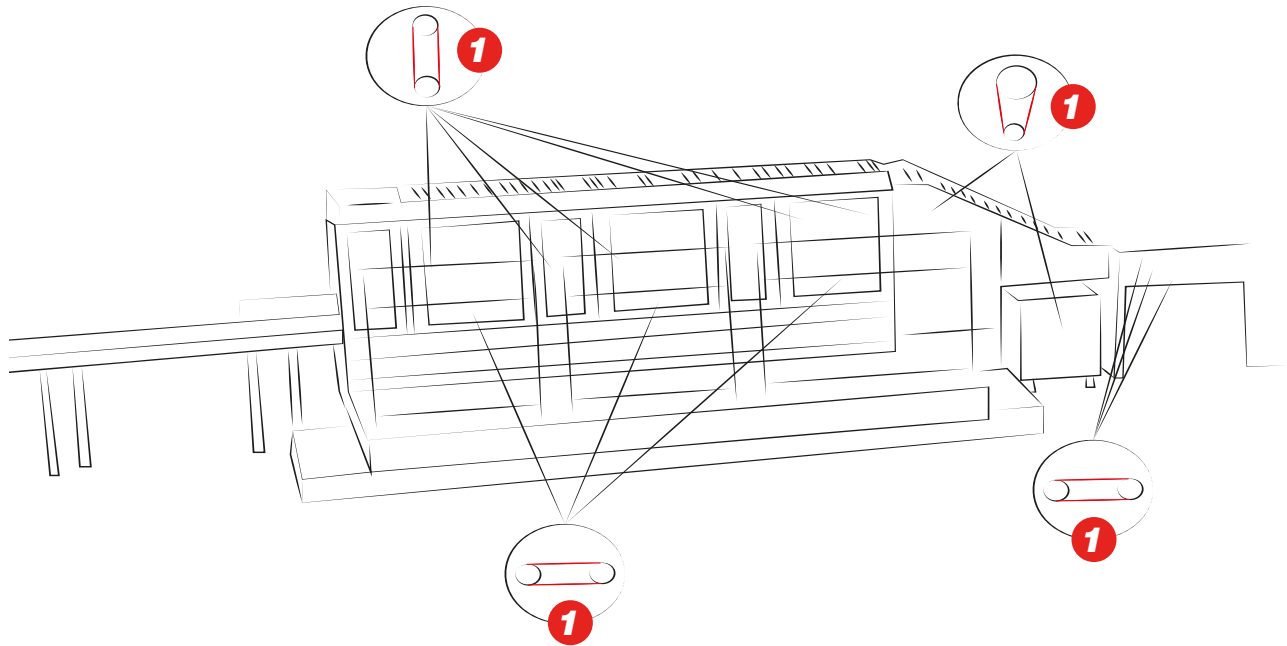

MEGADYNE MEGASYNC™ RUBBER ENDLESS TIMING BELTS

Rubber endless timing belts made of high-quality rubber compounds, and high-performance tension members.

- Moulded to length and pitch designation
- High-performance
- Low-noise

1 SPECIAL REWORKED BELTS

Truly endless moulded belts polyurethane or rubber based. Wide range of different materials, to ensure the best performances and the best match to the varied grades of film used. Grinded tooth and holes to ensure the best vacuum and grip performances.

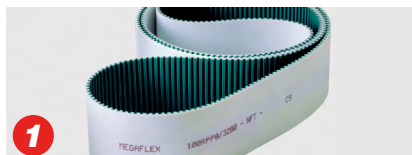

POLYURETHANE TIMING BELTS

Thermoplastic PU belts, supplied as open-length rolls or as endless joined belts; available in various tooth designs and grades of steel cord.

- High-positioning precision suitable for linear movement and lifting systems

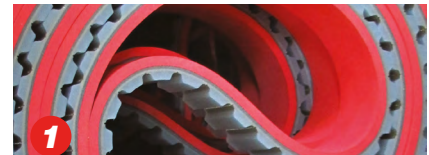

SPECIAL POLYURETHANE BELTS

Polyurethane moulded/laminated or joined belts with backing materials according to application demands.

- Non-marking
- High-friction even in high-speed conveying



Belts with anti-glaze cover



Belts with rubber coating and vacuum holes and slots



CASE STUDY

APPLICATION: Flat-bed die cutting machine

PREVIOUS SOLUTION: Competitor's belts can't handle high and irregular torque.

CHALLENGE WITH THIS SYSTEM: The belts in the die-cutting machine face high and irregular torque, causing wear, frequent failures, and inconsistent cutting quality, which compromise the final product's appearance and functionality.

MEGADYNE SOLUTION: MEGADYNE MEGASYNC™ TITANIUM

Produced with HNBR rubber and carbon fiber cords to handle high loads and variable peak torque, Titanium belts extend lifespan, boost efficiency, reduce downtime, and ensure consistent product quality.

For more information, scan the QRCode and discover more on Megadyne website and contact our experts.

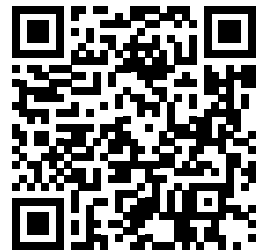

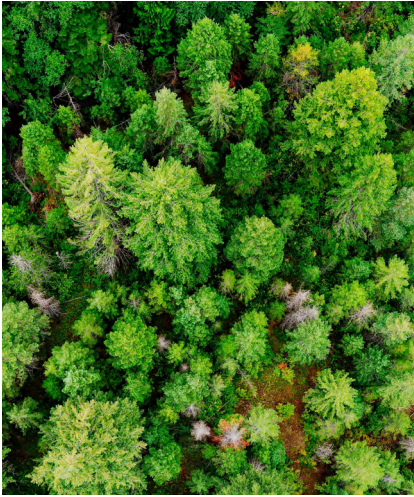

ABOUT SUSTAINABILITY

Sustainability has always been a guiding principle for AMMEGA and all members of AMMEGA Group. We are proud to work with **EcoVadis** to monitor and evaluate our environmental, social, and ethical performance.

At Megadyne, we are committed to becoming more and more responsible towards the world by reducing our impact on the planet. We work on new technological raw materials made by partners using the most ecological sustainable technologies. Our team has been working on the continuous improvement of products, services, and solutions for the benefit of society and the environment. Our vision is to be the local partner of choice for sustainable belting solutions around the globe.

CERTIFICATIONS



All Megadyne polyurethane power transmission belts comply with ISO 14001, ISO 9001 and European RoHS Directive. The belts are made with raw materials in compliance with REACH standards, meaning that all belts, pulleys, toothed bars, couplings blocking units and other items supplied by Megadyne do not contain one (or several) of the SVHC in Candidate List above a concentration of 0.1% w/w.

All Megadyne rubber power transmission belts are made in accordance with the Quality Management System Standard: ISO 9001 and ISO 14001. These certificates are valid for the following field of application: design, manufacture and sale of power transmission belts. Marketing of transmission and transport elements (pulleys, tensiometers).

MEMBERSHIPS



Discover Your Local Contacts

The local partner of choice
for sustainable power transmission belting solutions
around the globe.

General contact information:

Megadyne

Via Trieste, 16

Via S. Lucia 114 - 10075 Mathi (Torino)

Italy



Scan the QR code
and find your local
contact

