



CORD BREAK DETECTION SYSTEM

PRODUCT
BROCHURE

EN



CORD BREAK DETECTION SYSTEM

MEGADYNE MEGASMART LIFT BELT SCR & LIFT BELT INSPEK

Smart Belt Monitoring. Complete control.
Total Elevator Safety.

Safety and reliability in elevator installations depend not only on the quality of belts and pulleys, but on the integration of a complete system designed to continuously monitor operating conditions and react promptly to any anomaly.

For this reason, elevator belts can be combined with dedicated electronic safety devices that enhance system control and fault prevention. These solutions are designed to increase overall safety, minimize risks, and support more effective and preventive maintenance strategies.

Megadyne MEGASMART LIFT BELT SCR and **LIFT BELT INSPEK** are two key components of this system-based approach to elevator safety

Upgrade your traction system with active belt monitoring, ISO 8100 compliance, and a full package of intelligent accessories.

Talk to our experts today.

ADVANCED BELT MONITORING FOR MAXIMUM SAFETY

Our active monitoring systems continuously supervise belt integrity and loading conditions, helping ensure safe, reliable, and uninterrupted elevator operation.

ISO 8100 COMPLIANCE MADE SIMPLE

Designed to fully support compliance with ISO 8100 requirements, our solutions help manufacturers and operators meet the latest safety and performance standards with confidence.

COMPLETE TRACTION BELT SOLUTION

We offer a full solutions package for elevator traction system belts, including intelligent monitoring accessories for a fully integrated and future-ready system.

CORD BREAK DETECTION SYSTEM

LIFT BELT SCR

Immediate belt integrity monitoring

Megadyne MEGASMART **LIFT BELT SCR** is an electronic device designed for the detection of broken traction belts in elevator systems. By continuously monitoring the electrical continuity of the belt cores through dedicated belt connectors installed at the belt ends, SCR ensures constant supervision of belt integrity.

When a belt break or loss of continuity is detected, SCR immediately activates its internal relay, changing state and enabling rapid intervention on the elevator system.

Key benefits of SCR:

- Continuous monitoring of belt integrity
- Fast detection of belt breakage or discontinuity
- Immediate alarm signaling via relay output
- Easy integration into elevator control systems
- Increased safety and operational reliability

SCR is the ideal solution for applications requiring direct and reliable detection of critical belt failure events.

LIFT BELT INSPEK

Advanced load monitoring and preventive maintenance

Megadyne MEGASMART **LIFT BELT INSPEK** is an advanced system designed to monitor traction belt load and tension in elevator installations. Using load cells, fixed-point sensors, and dedicated belt connectors, INSPEK continuously measures mechanical and electrical parameters of the belts.

This continuous monitoring allows for early detection of anomalies such as loose belts, overload conditions, or belt breakage, supporting preventive maintenance strategies and reducing the risk of unexpected downtime.

Key benefits of INSPEK:

- Continuous monitoring of belt load, tension, or cord break
- Early identification of abnormal operating conditions
- Support for predictive and preventive maintenance
- Advanced alarm management and system diagnostics
- Integration with display and communication interfaces via CANopen or optional WiFi dongle

INSPEK is the ideal solution for applications requiring comprehensive, proactive monitoring, focused on maximum safety, efficiency, and system availability.



MEGASmart LIFT BELT SCR

Technical data

The SCR system features an internal relay that automatically switches state when a belt break is detected, enabling seamless connection to external signaling and control systems for immediate response.



SPECIFICATION		
PARAMETER	UNIT	VALUE
Model	-	SCR
Power supply (Min.)	VDC	18
Power supply (Max.)	VDC	36
Consumption	mA	100
Operating temperature range	°C (°F)	-10 / +65 (+14 / +149)
Storage temperature range	°C (°F)	-20 / +70 (-4 / +158)
Input wiring	-	Gx12 (2 contacts)
Relay max. voltage	VAC/VDC	48
Relay max. current	A	2
Relay quantity	-	1
Casing material	-	Fire-resistant ABS plastic
Protection class	-	IP54
LEDs	-	7
Keys	-	3

DIMENSIONAL DRAWINGS

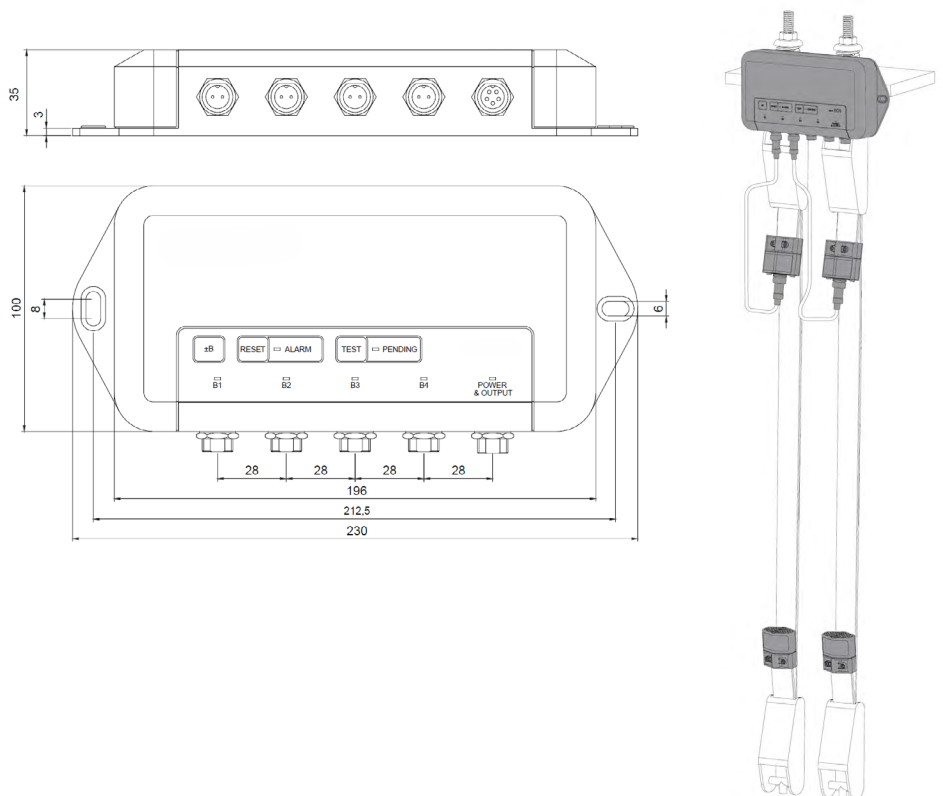

MEGASmart LIFT BELT INSPEK

Technical data

INSPEK allows the integration of load cells or fixed-point sensors to accurately monitor belt load, providing valuable data to optimize performance and enhance safety. INSPEK can be easily integrated with an external app, giving users real-time visibility of belt load and break detection status anytime, anywhere.



DIMENSIONAL DRAWINGS

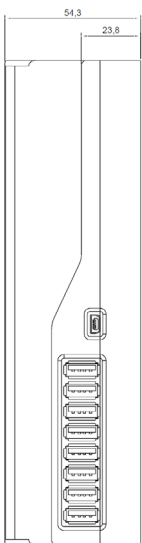
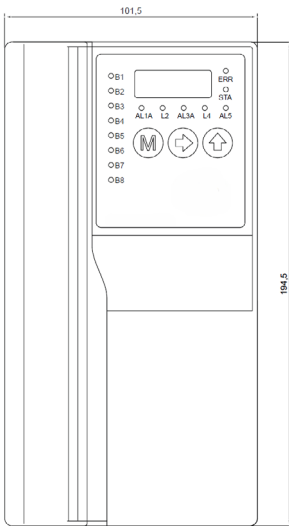

SPECIFICATION

PARAMETER	UNITS	SPECIFICATIONS	
Broken belt connector port	-	4 8	
Sensor Signal	Input range	±3.1	
	Input channel	4 8	
Accuracy of signal	-	0.03%	
Power supply	VDC	min 10 - max 40	
Maximum current consumption	mA	<200	
Temperature range	Working	°C (°F) -10 / +65 (+14 / +149)	
	Storage	°C (°F) -20 / +70 (-4 / +158)	
Relay	Contact	Max. voltage	VAC/VDC 48
		Max. Current	A 2A
	Number	Default state	- Normally open
Alarms	-	6	
Analog outputs (0-10V / 4-20mA / 0-20mA)	-	✓	
Cabin display output	-	Compatible with: MB (Multifunctional cabin display) and IDS (overload indicator)	
New Generation technology (with USB firmware upgrade)	-	✓	
Hold Input	VAC/VDC	24 / 48	
Interface	Display digits	- 5	
	Interface Keys	- 3	
	LEDs	- 16	
Casing material	-	Fire-resistant ABS plastic	
Fixing	-	DIN rail	
Protection class	-	IP50	

The system includes: Load Cells - Belt Connectors - Fixed-Point Sensors

ADDITIONAL COMPONENTS

BELT CONNECTORS

The connectors are **compatible with** Megadyne MEGASmart **LIFT BELT SCR** and Megadyne MEGASmart **LIFT BELT INSPEK**

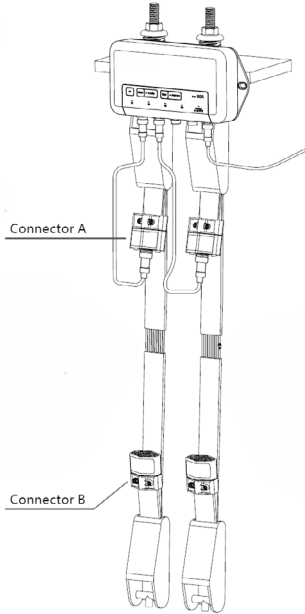

SPECIFICATION

PARAMETER		UNITS	SPECIFICATIONS
Load limit	Connector	-	GX12
	Contacts	-	2
Protection class		-	IP50

DIMENSIONAL DRAWINGS

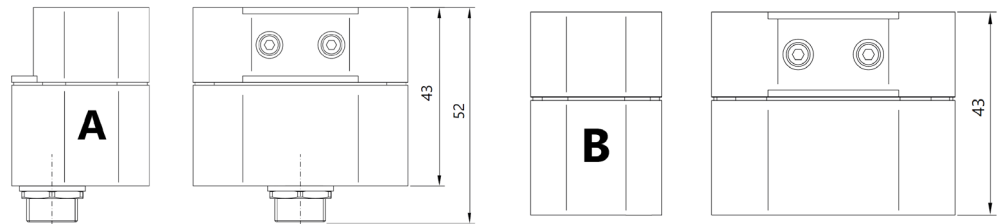

LOAD CELL



The Load Cell is **compatible with** Megadyne MEGASmart **LIFT BELT INSPEK** only.

SPECIFICATION

PARAMETER		UNITS	SPECIFICATIONS
Nominal Load (N.L.)		Kg	1000
Nominal Sensibility (N.S.)		mV/V	2,0 ± 0,01
Accuracy		-	1%
Max. excitation voltage		V	12
Temperature range	Compensated		-10 / +40 (+14 / +104)
	Operating	°C (°F)	-20 / +60 (-4 / +140)
	Storage		-20 / +70 (-4 / +158)
Min. insulation resistance (V. test= 100V)		GΩ	>4
Input resistance		Ω	150
Output resistance		Ω	>500
Load limit	Without loss	% N.L.	150
	Breaking		>500
Cable	Connector	-	USB
	Wire Diameter	-	4 x 0,14 mm² ø 4,3
	Dimension	m	2
	Material	-	Polyurethane (PU)
Load cell	Material	-	Alloy steel
	Surface treatment	-	Chemical nickel
Protection class		-	IP50

DIMENSIONAL DRAWINGS

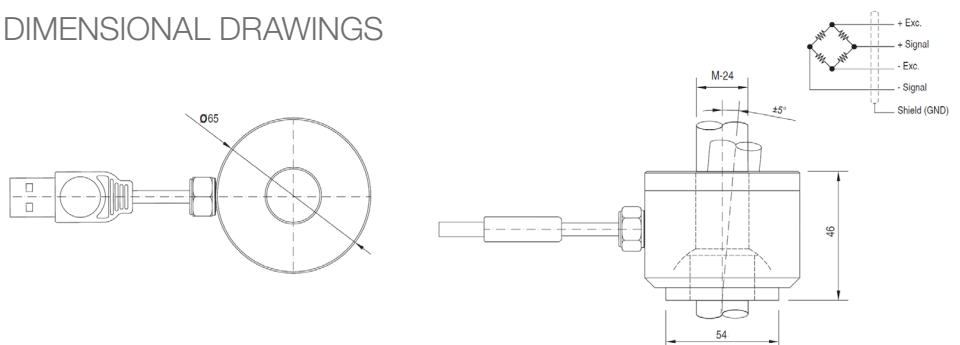

CORD BREAK DETECTION SYSTEM

megadynegroup.com

ADDITIONAL COMPONENTS

FIXED POINT SENSOR

The Fixed Point Sensor is **compatible with** Megadyne MEGASmart **LIFT BELT INSPEK** only.



SPECIFICATION

PARAMETER	UNITS	SPECIFICATIONS	
Nominal Load (N.L.)	Kg	700	
Nominal Sensibility (N.S.)	mV/V	1,3 / 2,0	
N.S. difference between sensor	% N.S.	2	
Accuracy	-	0,25%	
Max. excitation voltage	V	12	
Minimum distance to the socket	cm	25	
Temperature range	Compensated	-10 / +40 (+14 / +104)	
	Operating	-20 / +60 (-4 / +140)	
	Storage	-20 / +70 (-4 / +158)	
Min. insulation resistance (V. test= 100V)	GΩ	4	
Input resistance	Ω	350 / 400	
Output resistance	Ω	350 ± 1,5	
Load limit	Without loss	840	
	Breaking	1050	
Cable	Connector	-	USB
	Wire Diameter	-	4 x 0,14 mm ² ø 4,3
	Dimension	m	0,75 or 2
	Material	-	Polyurethane (PU)
Load cell	Material	-	Aluminium
	Surface treatment	-	Anodized
Protection class	-	-	IP65

DIMENSIONAL DRAWINGS

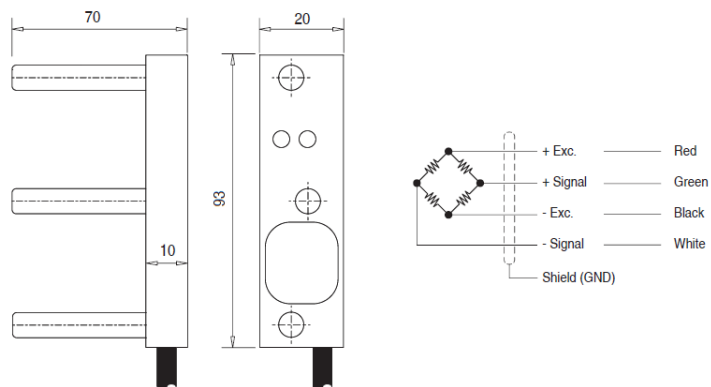

**Contact us for
more information**

CORD BREAK DETECTION SYSTEM

megadynegroup.com

Discover Your Local Contacts

The local partner of choice
for sustainable power transmission belting solutions
around the globe.



General contact information:

Megadyne

Via Trieste, 16
Via S. Lucia 114 - 10075 Mathi (Torino)
Italy



Scan the QR code
and find your local
contact

